

Lenovo Flex System EN4093R 10Gb Ethernet Scalable Switch

Installation Guide

LenovoTM

Important Product Information—

Before using this information and the product it supports, read [Appendix B, “Notices”](#) on [page 59](#) of this manual. Also read the product *Warranty Information* document, the *Important Notices* document, the *Safety Information* document, the *License Agreement for Machine Code (LAMC)* document, and the *Environmental Notices and User Guide* document located at [Lenovo System x, ThinkServer and Storage product documentation](#).

July 2017 Edition

© Copyright Lenovo 2017
Portions © Copyright IBM Corporation 2014.

LIMITED AND RESTRICTED RIGHTS NOTICE: If data or software is delivered pursuant a General Services Administration “GSA” contract, use, reproduction, or disclosure is subject to restrictions set forth in Contract No. GS-35F-05925.

Lenovo and the Lenovo logo are trademarks of Lenovo in the United States, other countries, or both.

Contents

Safety Information	.5
Safety Statements	7
UL Regulatory Information	8
Chapter 1. The EN4093R 10Gb Ethernet Scalable Switch.	.9
Documentation	.12
About this <i>Installation Guide</i>	.12
Notices and Statements in this Document	.12
Related Documentation	.13
Chapter 2. Installing and Removing the EN4093R.	15
Before Installing the EN4093R	.17
Installation Guidelines	.18
System Reliability Guidelines	.19
Handling Static-Sensitive Devices	.19
Installing the EN4093R	.20
Removing or Replacing the Switch	.22
Connecting Switch Ports	.23
The Serial Console Port	.23
The RJ-45 Management Port	.24
Handling Transceiver Modules	.25
SFP+ Ports	.26
QSFP+ Ports	.29
Locating the Information Panels, LEDs, and External Ports	.32
Information Panel	.32
Information LEDs	.34
Chapter 3. Configuring the EN4093R	37
Establishing an Interface Through the CMM	.39
Enabling Management Through Data Ports	.40
Accessing the Switch Through the SSHv2/Telnet Interface	.41
Accessing the Switch Through the Serial-Port Interface	.42
Accessing the Switch Through the Browser-Based Interface	.43
Initial Configuration	.44
Chapter 4. Updating the Firmware and Licensing	45
Determining the Level of Switch Firmware	.46
Obtaining the Latest Level of Switch Firmware	.47
Upgrading the Switch Firmware	.48
Switch Firmware Upgrade Example	.49
Resetting and Restarting the Switch	.50
Acquiring Feature Licenses	.51
Installing Feature Licenses	.52
Chapter 5. Solving Problems	53
Running POST	.54
POST Errors	.55
Parts listing	.56

Appendix A. Getting Help and Technical Assistance	57
Appendix B. Notices	59
Trademarks	61
Important Notes	62
Recycling information.	63
Particulate Contamination.	64
Telecommunication Regulatory Statement	65
Electronic Emission Notices	66
Federal Communications Commission (FCC) Statement	66
Industry Canada Class A Emission Compliance Statement	66
Avis de Conformité à la Réglementation d'Industrie Canada	66
Australia and New Zealand Class A Statement	66
European Union - Compliance to the Electromagnetic Compatibility Directive	67
Germany Class A Statement	67
VCCI Class A Statement	68
Japan Electronics and Information Technology Industries Association	
(JEITA) Statement.	69
Korea Communications Commission (KCC) Statement.	69
Russia Electromagnetic Interference (EMI) Class A Statement.	69
People's Republic of China Class A Electronic Emission Statement	69
Taiwan BSMI RoHS Declaration	70
Taiwan Class A Compliance Statement	70

Safety Information

Before installing this product, read the Safety Information.

قبل تركيب هذا المنتج، يجب قراءة الملاحظات الأمنية

Antes de instalar este produto, leia as Informações de Segurança.

在安装本产品之前，请仔细阅读 **Safety Information** (安全信息)。

安裝本產品之前，請先閱讀「安全資訊」。

Prije instalacije ovog produkta obavezno pročitajte Surgonosne Upute.

Před instalací tohoto produktu si přečtěte příručku bezpečnostních instrukcí.

Læs sikkerhedsforskrifterne, før du installerer dette produkt.

Lees voordat u dit product installeert eerst de veiligheidsvoorschriften.

Ennen kuin asennat tämän tuotteen, lue turvaohjeet kohdasta Safety Information.

Avant d'installer ce produit, lisez les consignes de sécurité.

Vor der Installation dieses Produkts die Sicherheitshinweise lesen.'

Πριν εγκαταστήσετε το προϊόν αυτό, διαβάστε τις Πληροφορίες ασφαλείας (safety information).

לפני שתתקינו מוצר זה, קראו את הוראות הבטיחות.

A termék telepítés előtt olvassa el a Biztonsági előírásokat!

Prima di installare questo prodotto, leggere le Informazioni sulla Sicurezza.

製品の設置の前に、安全情報をお読みください。

본 제품을 설치하기 전에 안전 정보를 읽으십시오.

Пред да инсталира овој продукт, прочитајте информацијата за безбедност.

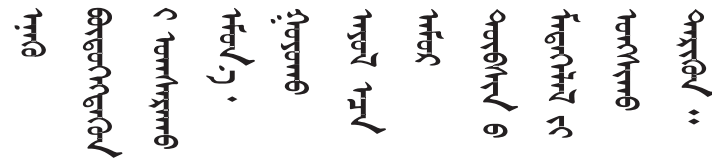

Les sikkerhetsinformasjonen (Safety Information) før du installerer dette produktet.

Przed zainstalowaniem tego produktu, należy zapoznać się z książką "Informacje dotyczące bezpieczeństwa" (Safety Information).

Antes de instalar este produto, leia as Informações sobre Segurança.

Перед установкой продукта прочтите инструкции по технике безопасности.

Pred inštaláciou tohto zariadenia si prečítajte Bezpečnostné predpisy.

Pred namestitvijo tega proizvoda preberite Varnostne informacije.

Antes de instalar este producto, lea la información de seguridad.

Läs säkerhetsinformationen innan du installerar den här produkten.

ཐོན་ཁུངས་འདི་བདེ་སྤྱོད་མ་བྱས་གོང་། སློབ་གྲི་ཡིད་གཟབ་
བྱ་འདྲ་མིན་ཡོད་པའི་འོད་སྤེལ་བལྟ་དགོས།

Bu ürünü kurmadan önce güvenlik bilgilerini okuyun.

مەزكۇر مەھسۇلاتنى ئورنىتىشتىن بۇرۇن بىخەتەرلىك ئۇچۇرلىرىنى ئوقۇپ چىقىڭ.

Youq mwngz yungh canjbinj neix gaxgonq, itdingh aeu doeg aen canjbinj soengq
cungj vahgangj ancien suisik.

Safety Statements

Important—

Each caution and danger statement in this document is labeled with a number. This number is used to cross reference the English-language caution or danger statement with the translated versions of the caution or danger statement in the *Safety Information* document.

For example, if a caution statement is labeled “Statement 1,” translations for that caution statement are in the *Safety Information* document under “Statement 1.”

Be sure to read all caution and danger statements in this document before you perform the procedures. Read any additional safety information that comes with the system or optional device before you install the device.

Following is a compilation of the statements found throughout this manual.

Statement 1



DANGER

Electrical current from power, telephone, and communication cables is hazardous.

To avoid a shock hazard:

- **Do not connect or disconnect any cables or perform installation, maintenance, or reconfiguration of this product during an electrical storm.**
- **Connect all power cords to a properly wired and grounded electrical outlet.**
- **Connect to properly wired outlets any equipment that will be attached to this product.**
- **When possible, use one hand only to connect or disconnect signal cables.**
- **Never turn on any equipment when there is evidence of fire, water, or structural damage.**
- **Disconnect the attached power cords, telecommunications systems, networks, and modems before you open the device covers, unless instructed otherwise in the installation and configuration procedures.**
- **Connect and disconnect cables as described in the following table when installing, moving, or opening covers on this product or attached devices.**

To Connect:

1. Turn everything OFF.
2. First, attach all cables to devices.
3. Attach signal cables to connectors.
4. Attach power cords to outlet.
5. Turn device ON.

To Disconnect:

1. Turn everything OFF.
2. First, remove power cords from outlet.
3. Remove signal cables from connectors.
4. Remove all cables from devices.

Statement 3



CAUTION:

When laser products (such as CD-ROMs, DVD drives, fiber optic devices, or transmitters) are installed, note the following:

- Do not remove the covers. Removing the covers of the laser product could result in exposure to hazardous laser radiation. There are no serviceable parts inside the device.
- Use of controls or adjustments or performance of procedures other than those specified herein might result in hazardous radiation exposure.



DANGER

Some laser products contain an embedded Class 3A or Class 3B laser diode. Note the following.

Laser radiation when open. Do not stare into the beam, do not view directly with optical instruments, and avoid direct exposure to the beam.



Class 1 Laser Product
Laser Klasse 1
Laser Klass 1
Luokan 1 Laserlaite
Appareil À Laser de Classe 1

Statement 25



CAUTION:

This product contains a Class 1M laser. Do not view directly with optical instruments.

UL Regulatory Information

This device is for use only with listed Lenovo Flex System Enterprise Chassis.

Chapter 1. The EN4093R 10Gb Ethernet Scalable Switch

This Installation Guide provides information about the Lenovo® Flex System™ Fabric EN4093R 10Gb Ethernet Scalable Switch (referred to as EN4093R or “switch” throughout this document).

Figure 1. The EN4093R

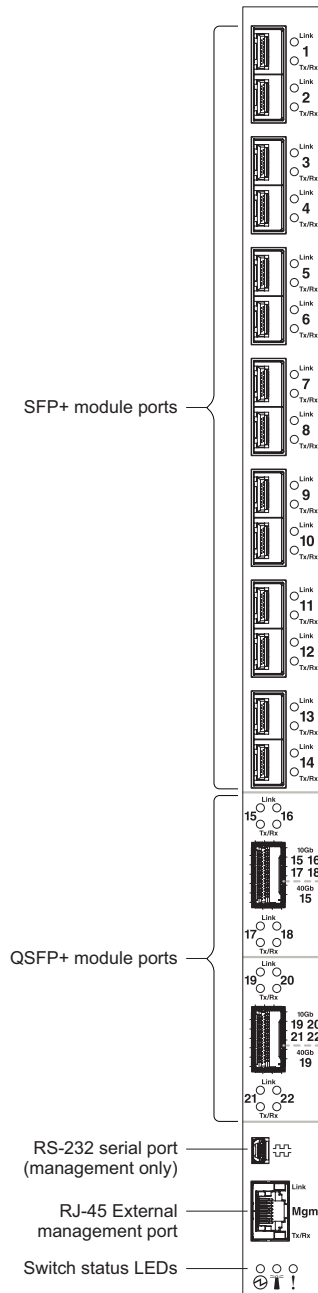

Note: The illustrations in this document might differ slightly from your hardware.

The EN4093R provides flexible, reliable, and high-performance features that meet the demands of today's highly virtualized environments.

The EN4093R provides pay-as-you-grow scalability. With optional licensing, you can easily and cost-effectively expand the number of available ports.

Depending on the installed licenses, the scalable switch can provide up to sixty-four 10 Gigabit Ethernet (GbE) ports.

The base license provides support for twenty-four 10 GbE ports:

- Single compute node port capability (fourteen internal 10 GbE ports)
- Ten external 10 GbE Small Form-factor Pluggable Plus (SFP+) ports

Additional ports are available with optional licenses. There are two upgrades that are available for the EN4093R (see [“Acquiring Feature Licenses”](#) on page 51).

Upgrade 1 supports up to twenty-two additional ports (up to forty-six total):

- Dual compute node port capability (fourteen additional internal ports)
- Two external 40 GbE Quad Small Form Pluggable Plus (QSFP+) ports, each of which can be optionally used as four SFP+ ports

Upgrade 2 supports eighteen additional ports (up to sixty-four total)

- Triple compute node port capability (fourteen additional internal ports)
- Four additional external SFP+ ports

Note: Upgrade 1 is a prerequisite to Upgrade 2.

SFP+ ports can be populated with 10 Gb optical or copper SFP+ transceiver modules or Direct-Attach Cables (DACs), or legacy 1 Gb optical or copper SFP transceiver modules.

QSFP+ ports can be populated with optical QSFP+ modules or DACs, including some that accept SFP+ or SFP modules.

In addition to port flexibility, you can manage and configure the EN4093R through the following interfaces:

- A Secure Shell (SSH) version 2 or Telnet connection to the embedded Command-Line Interface (CLI)
- A terminal emulation program connection to the serial port interface
- A network management application using Simple Network Management Protocol (SNMP)
- A Web browser-based interface (HTTPS/HTTP) connection to the switch

Documentation

About this *Installation Guide*

This *Installation Guide* provides information and instructions for installing the EN4093R, updating the firmware, and solving problems. For other information about configuration and management of the switch, refer to the documents described in [“Related Documentation” on page 13](#).

Note:

- The illustrations in this document might differ slightly from your hardware and might not depict all included labels.
- The console output described or referenced in this document might differ slightly from that displayed by your system. Output varies according to the type of Lenovo chassis and the firmware versions and options that are installed.

Notices and Statements in this Document

The *caution* and *danger* statements in this document are also in the multilingual *Safety Information* document, which is located at [Lenovo System x, ThinkServer and Storage product documentation](#). Each statement is numbered for reference to the corresponding statement in the *Safety Information* document.

The following notices and statements are used in this document:

- **Note:** These notices provide important tips, guidance, or advice.
- **Important:** These notices provide information or advice that might help you avoid inconvenient or problem situations.
- **Attention:** These notices indicate potential damage to programs, devices, or data. An attention notice is placed just before the instruction or situation in which damage could occur.
- **Caution:** These statements indicate situations that can be potentially hazardous to you. A caution statement is placed just before the description of a potentially hazardous procedure step or situation.
- **Danger:** These statements indicate situations that can be potentially lethal or extremely hazardous to you. A danger statement is placed just before the description of a potentially lethal or extremely hazardous procedure step or situation.

Related Documentation

Additional or updated product documents may be available from the Lenovo website. Such documents may cover features not described in the original documentation that comes with the switch, or may include technical updates or corrections.

You can obtain up-to-date information on the Lenovo support website:

<http://support.lenovo.com/>

Note: Changes are made periodically to the Lenovo website. Procedures for locating firmware and documentation might vary slightly from what is described in this document.

For information about switch hardware and firmware features, specifications, and standards, including their configuration, see the *Application Guide* for your specific switch and its installed firmware.

For information about the switch information, statistics, and individual configuration parameters, see the *Command Reference* for your specific switch and its installed firmware.

See the documentation that came with your Lenovo chassis for information about the environmental conditions and specifications that are supported by the system.

Chapter 2. Installing and Removing the EN4093R

This chapter provides instructions for installing and removing the EN4093R in the Lenovo Flex System chassis. See the documentation for your Lenovo Flex System chassis for information about I/O bay locations and the components that can be installed in them that is specific to your Lenovo Flex System chassis type.

The following illustration shows an example of a Lenovo Flex System chassis (rear-view) with the I/O bays identified.

Figure 2. Flex System chassis I/O bays.

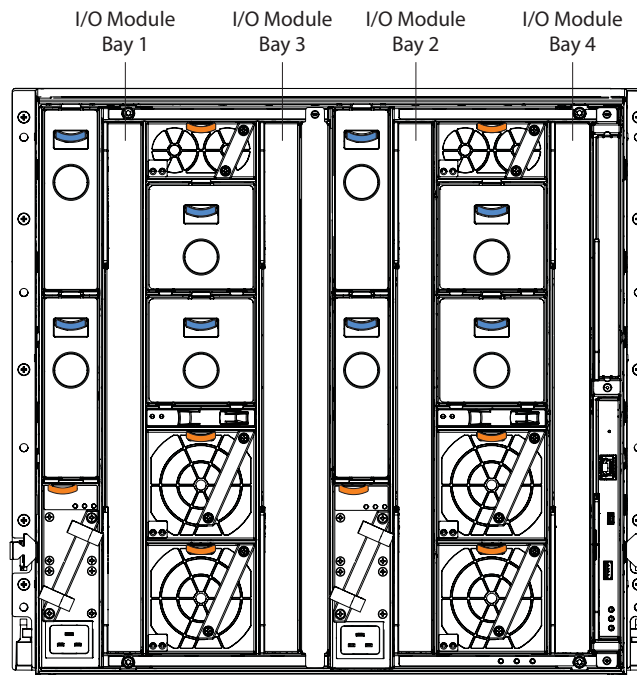

A Lenovo Flex System network adapter must be installed in each compute node with which you want to communicate. To enable the switch to communicate with a compute node, at least one switch must be installed in the Lenovo Flex System chassis. For details about network adapter installation, configuration, and use, see the documentation that comes with the Lenovo Flex System network adapter.

Installing a second switch enables a redundant path and a separate connection from the compute node to the external Ethernet network.

The Lenovo Flex System chassis supports a maximum of four EN4093R modules. The Lenovo Flex System chassis supports a maximum of twenty-eight network adapters.

Note:

- I/O bays 1 and 2 support any standard Lenovo Flex System switch or pass-thru module. When you install an I/O network adapter in the left-most fabric connector on the compute node, these I/O bays support any switch with the same type of network interface that is used by the corresponding network adapter.
- I/O bays 3 and 4 support any standard Lenovo Flex System switch or pass-thru module. When you install an I/O network adapter in the right-most fabric connector on the compute node, these I/O bays support any switch with the same type of network interface that is used by the corresponding network adapter.
- The compute nodes or Lenovo Flex System chassis that are described or shown in this document might be different from your compute node or Lenovo Flex System chassis. For additional information, see the documentation that comes with your Lenovo Flex System chassis.
- When the switch is installed in a Lenovo Flex System chassis, the internal ports operate at 1 Gigabits per second (Gbps) or 10 Gbps. The external ports can operate at 1 Gbps, 10 Gbps, or 40 Gbps, depending on the port type and installed transceiver modules.

Before Installing the EN4093R

Attention: Product information is required in order to register your EN4093R, update its firmware, place a service call, or replace the unit.

Some of the product information labels may be hidden from view once the EN4093R is installed. To prevent the need to remove the switch in order to read required product information, locate and record the information shown on [Table 1 on page 18](#) prior to installation.

An example of the product information labels is shown as follows:

Figure 3. Sample product labels from the switch

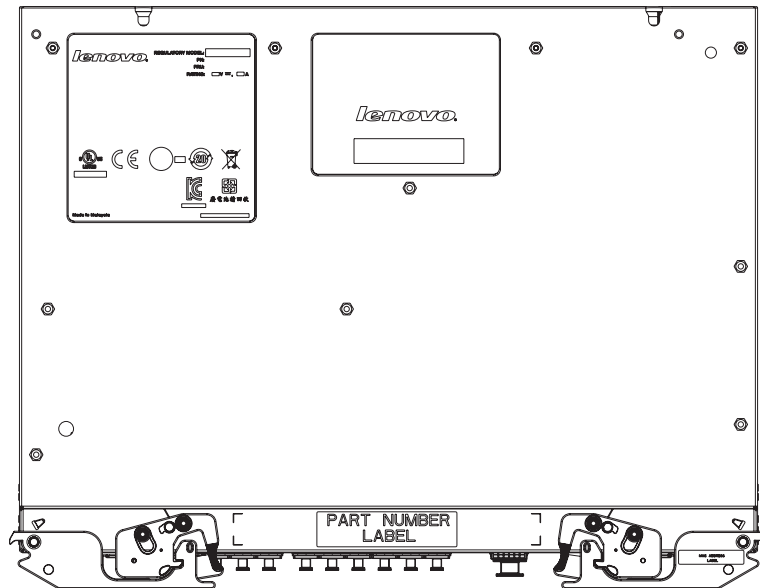

Note: These examples are to help locate and identify the information labels. The actual labels and information for your specific switch may differ.

The identification labels on the EN4093R contain the serial number and part number of the switch. These labels also include the Media Access Control (MAC) address (on the uppermost handle) of the switch. Though helpful, the MAC address is not required for opening a service call.

Print this page and record product information below. Keep the information in a safe place for future reference. You will need this information when you register the switch or open a service call with Lenovo.

Table 1. *Important product information*

Product Name	Lenovo Flex System EN4093R 10Gb Ethernet Scalable Switch
Serial Number	
Part Number	
Media Access Control (MAC) address for switch	
MAC addresses for other components	

For convenience, once the EN4093R is installed and initialized, you can use the `show sys - info` command in the switch firmware interface to display the product serial number and other required information.

Installation Guidelines

Before you install the switch in the Lenovo Flex System chassis, read the following information:

- Read the safety information that begins on [page 5](#), “[Handling Static-Sensitive Devices](#)” on [page 19](#), and the safety statements in the Lenovo Flex System chassis documentation. This information provides a safe working environment.
- Observe good housekeeping in the area where you are working. Place removed covers and other parts in a safe place.
- Blue on a component indicates touch points, where you can grip the component to remove it from or install it in the compute node or Lenovo Flex System chassis, open or close a latch, and so on.
- Orange on a component or an orange label on or near a component on the switch, compute node, or Lenovo Flex System chassis indicates that the component can be hot-swapped, which means that if the Lenovo Flex System chassis and operating system support hot-swap capability, you can remove or install the component while the Lenovo Flex System chassis is running. (Orange can also indicate touch points on hot-swap components.) See the instructions for removing or installing a specific hot-swap component for any additional procedures that you might have to perform before you remove or install the component.
- You do not have to turn off the Lenovo Flex System chassis to install or replace any of the hot-swap modules on the front or rear of the Lenovo Flex System chassis.
- When you install the switch in the Lenovo Flex System chassis, you must also install a compatible I/O network adapter in the compute node to support the switch.
- When you are finished working on the compute node or Lenovo Flex System chassis, reinstall all safety shields, guards, labels, and ground wires.

System Reliability Guidelines

To help ensure proper cooling, performance, and system reliability, make sure that the following requirements are met:

- Each of the bays on the rear of the Lenovo Flex System chassis contains either a module or a filler module.
- A removed hot-swap module is replaced with an identical module or filler module within one minute of removal.
- A removed hot-swap compute node is replaced with another compute node or filler node within one minute of removal.
- The ventilation areas on the sides of the compute node are not blocked.
- You have followed the reliability guidelines in the documentation that comes with the Lenovo Flex System chassis.

Handling Static-Sensitive Devices

Attention: Static electricity can damage the switch and other electronic devices. To avoid damage, keep static-sensitive devices in their static-protective packages until you are ready to install them.

To reduce the possibility of electrostatic discharge, observe the following precautions:

- Limit your movement. Movement can cause static electricity to build up around you.
- The use of a grounding system is recommended. For example, wear an electrostatic-discharge wrist strap, if one is available.
- Handle the device carefully, holding it by its edges or its frame.
- Do not touch solder joints, pins, or exposed printed circuitry.
- Do not leave the device where others can handle and damage it.
- While the device is still in its static-protective package, touch it to an *unpainted* metal part of any *unpainted* metal surface on a grounded rack component in the rack in which you are installing the device, for at least two seconds. This drains static electricity from the package and from your body.
- Remove the device from its package and install it directly into the switch without setting it down. If it is necessary to set down the device, put it back into its static-protective package. Do not place the device on a switch cover or on a metal surface.
- Take additional care when you handle devices during cold weather. Heating reduces indoor humidity and increases static electricity.
- Some types of Lenovo Flex System chassis come with electrostatic discharge (ESD) connectors. If your unit is equipped with an ESD connector, see the documentation that comes with the Lenovo Flex System chassis for using the ESD connector.

Installing the EN4093R

Note: The following illustration shows how to install the switch in a Lenovo Flex System chassis. The appearance of your Lenovo Flex System chassis might be different; see the documentation for your Lenovo Flex System chassis for additional information.

Use the following instructions to install the switch in the Lenovo Flex System chassis. You can install the switch while the Lenovo Flex System chassis is powered on. For redundancy support, you must install I/O modules of the same type in I/O bays 1 and 2, and I/O modules of the same type in bays 3 and 4 of the chassis.

To install the switch, complete the following steps.

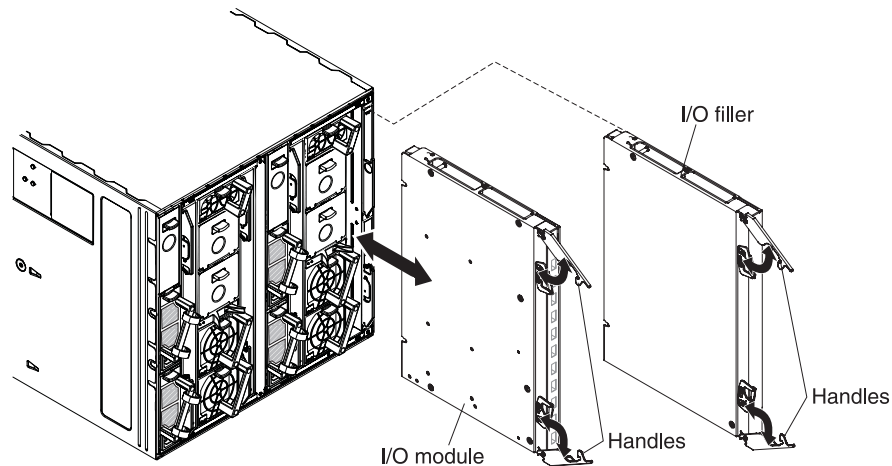

1. Read the safety information that begins on [page 5](#) and [“Installation Guidelines” on page 18](#).

2. Select I/O bay in which to install the switch.

Note: For details about I/O bay requirements and bay locations, see the documentation for the Lenovo Flex System chassis.

3. Remove the filler module from the selected bay. Store the filler module for future use.
4. If you have not already done so, touch the static-protective package that contains the switch to an *unpainted* metal surface of the Lenovo Flex System chassis or an *unpainted* metal surface on any other grounded rack-component for at least 2 seconds.
5. Remove the switch from its static-protective package.
6. Make sure that the release levers on the switch are in the open position (perpendicular to the switch).
7. Slide the switch into the applicable I/O bay until it stops.

8. Push the release levers on the front of the switch to the closed position. After you insert and lock the switch, it is turned on (there may be a slight delay), and a Power-On Self-Test (POST) occurs to verify that the switch is operating correctly.

Note: The switch may take up to two minutes to complete the POST. During POST, the Power LED continuously flashes. Once POST has successfully completed, the Power LED remains on and the Error LED is off.

9. Make sure that LEDs on the switch indicate that it is operating correctly (see [“Information LEDs” on page 34](#)).
10. If you have another switch to install, repeat [Step 3](#) through [Step 9](#); otherwise, go to the next step.
11. Install any port transceiver modules or Direct-Attach Cables (DACs) needed for the switch. For information and instructions, see [“Connecting Switch Ports” on page 23](#) and the documentation that comes with the transceiver modules or DACs.
12. Attach any cables that are required by the switch. For additional information about cabling the switch, see [“Connecting Switch Ports” on page 23](#), the documentation that comes with the port transceiver modules, DACs, cables, and the optional network devices to which the cables are connected.
13. Make sure that the data (non-management) ports on the switch are enabled through the Chassis Management Module (CMM).

Removing or Replacing the Switch

Note: The following illustration shows how to remove and replace the switch from the Lenovo Flex System chassis. The appearance of your Lenovo Flex System chassis might be different; see the documentation for your Lenovo Flex System chassis for additional information.

To replace the switch, complete the following steps.

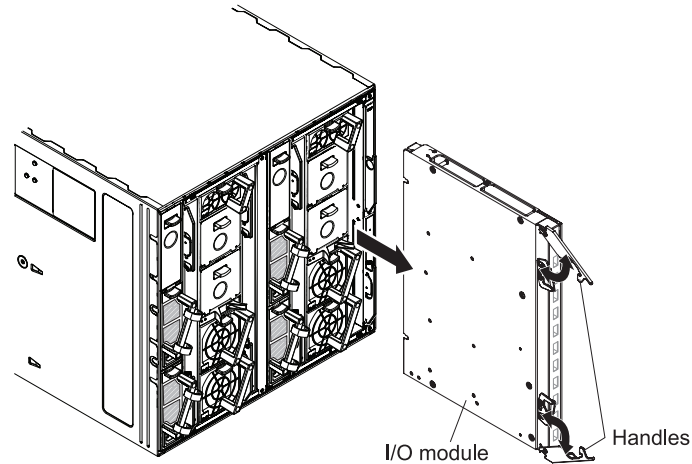

1. Read the safety information that begins on [page 5](#), and “[Installation Guidelines](#)” on [page 18](#).
2. Detach any cables that are attached to the switch you will be removing.

Note: Detaching cables from the switch ports disrupts the network connection from the switch to any connected external devices. If you plan to replace the switch with another switch, you can reuse the existing cables, provided they remain securely attached to the network.

3. Pull the release latches out from the switch. The switch moves out of the bay approximately 0.6 cm (0.25 inch).
4. Slide the switch out of the bay and set it aside in a safe, static-free location.
5. Place either another switch or a filler module in the bay.

Important: Complete this step within 1 minute. For more information, see “[Installing the EN4093R](#)” on [page 20](#).

6. If you placed the switch in the bay, reconnect the ports that you disconnected in [Step 2](#) and attach any additional cables that are required by the switch.

For additional information about connecting ports, see “[Connecting Switch Ports](#)” on [page 23](#), and also the documentation that comes with the port transceiver modules, DACs, cables, and the optional network devices to which the cables have been connected.

Connecting Switch Ports

The switch includes a variety of external port options. Fixed ports, such as the RJ-45 management port, can be connected directly by attaching the appropriate cable. Modular ports, such as Small Form-factor Pluggable Plus (SFP+) and Quad Small Form-factor Pluggable Plus (QSFP+) ports, require the installation of a transceiver module before the cable can be attached. This section covers each supported port type separately:

- [“The Serial Console Port” on page 23](#)
- [“The RJ-45 Management Port” on page 24](#)
- [“SFP+ Ports” on page 26](#)
- [“QSFP+ Ports” on page 29](#)

Notes:

- The illustrations in this document might differ slightly from your hardware.
- While the information in this section describes the 10 Gigabit Ethernet (GbE) SFP+ transceiver module, it also applies to the 1 GbE SFP transceiver module.
- The switch supports MSA-compliant copper DACs, up to 5 m (16.5 ft.) in length.

The Serial Console Port

Connecting the Serial Console Cable

To use the serial console, connect a serial cable to the RS-232 serial console port of the switch and the other end of the cable to the console device.

Note: You must use one of the two cables in the Serial Access Cable option.

If your console device uses a standard RS-232 DB9 connector, attach the included mini-USB-to-DB9 serial cable. Otherwise, if your console device uses an RJ-45 connector, attach the included mini-USB-to-RJ-45 serial cable and a user-supplied RJ-45 adapter cable. Your adapter cable depends on the pin out required by your console device. Pin out of the mini-USB-to-RJ-45 cable is as follows:

Table 2. Pin out for the included mini-USB-to-RJ-45 cable

PIN #	Function	Direction
1	Not connected	
2	RXD	In
3	TXD	Out
4	GND	
5	GND	
6	Not connected	
7	Not connected	
8	Not connected	

For additional information, see [“Accessing the Switch Through the Serial-Port Interface”](#) on page 42.

Disconnecting the Serial Console Cable

To disconnect the serial console cable, grasp the connector and gently pull the cable from the switch.

The RJ-45 Management Port

Connecting RJ-45 Cables

RJ-45 cables can be connected to the to external management port, and also to SFP+ ports that have legacy 1000BASE-T SFP transceiver modules.

To connect the RJ-45 connector to the switch, push the RJ-45 cable connector into the port connector until it clicks into place.

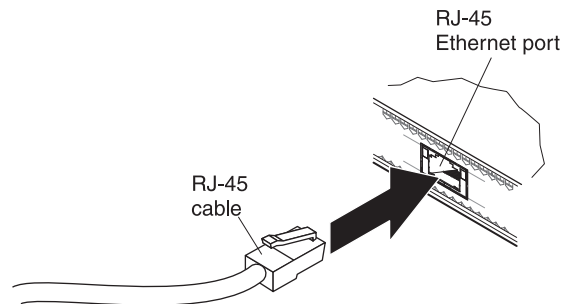

Disconnecting RJ-45 Cables

To disconnect the RJ-45 cable, squeeze the release tab and gently pull the cable connector out of the switch connector.

Handling Transceiver Modules

The switch supports the 10 GbE SFP+ module, the 1 GbE SFP module, and the QSFP+ module.

Before you install transceiver modules, read the following information.

- The housing of the transceiver modules has an integral guide key that is designed to prevent you from inserting the module incorrectly.
- Use minimal pressure when you insert the module into the switch port. Forcing the module into the port can cause damage to the module or port.
- You can insert or remove the module while the Lenovo Flex System chassis is turned on.
- You must first insert the module into the switch port before you can connect the cables.
- You must remove the cable from the transceiver module before you remove the module from the switch port.

Statement 3



CAUTION:

When laser products (such as CD-ROMs, DVD drives, fiber optic devices, or transmitters) are installed, note the following:

- **Do not remove the covers. Removing the covers of the laser product could result in exposure to hazardous laser radiation. There are no serviceable parts inside the device.**
- **Use of controls or adjustments or performance of procedures other than those specified herein might result in hazardous radiation exposure.**



DANGER

Some laser products contain an embedded Class 3A or Class 3B laser diode. Note the following.

Laser radiation when open. Do not stare into the beam, do not view directly with optical instruments, and avoid direct exposure to the beam.



**Class 1 Laser Product
Laser Klasse 1
Laser Klass 1
Luokan 1 Laserlaite
Appareil À Laser de Classe 1**

SFP+ Ports

The switch SFP+ ports accept SFP+ modules that provides two fiber-optic cable connectors for connecting to external devices.

Installing an SFP+ Module

To install an SFP+ module, complete the following steps.

1. Read the safety information that begins on [page 5](#) and “[Installation Guidelines](#)” on [page 18](#).
2. If you have not already done so, touch the static-protective package that contains the SFP+ module to an *unpainted* metal surface of the Lenovo Flex System chassis or an *unpainted* metal surface on any other grounded rack component in the rack in which you are installing the switch for at least 2 seconds.
3. Read the information in “[Handling Transceiver Modules](#)” on [page 25](#).
4. Remove the SFP+ module from its static-protective package.
5. If a protective cap is installed in the switch SFP+ port where you are installing the SFP+ module, remove the cap and store it in a safe place.
6. Remove the protective cap from the SFP+ module and store it in a safe place.
Attention: To avoid damage to the cable or the SFP+ module, make sure that you do not connect the fiber optic cable before the SFP+ module is installed in the switch port.
7. Insert the SFP+ module into the switch SFP+ port until it clicks into place.

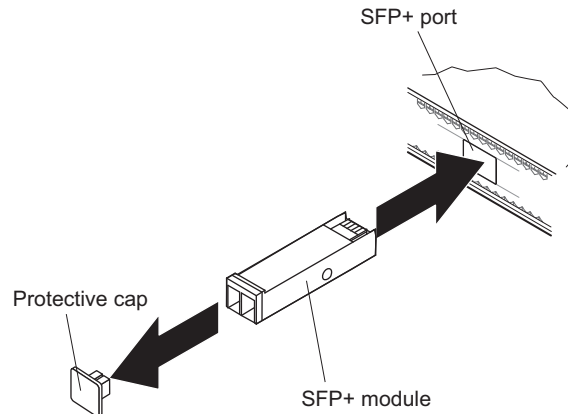

8. Connect the fiber optic cable (see “[Attaching a Fiber Optic Cable](#)” on [page 27](#)) and any cables that you disconnected earlier.

Attaching a Fiber Optic Cable

Attention: To avoid damage to the fiber optic cable, follow these guidelines:

- Do not route the cable along a folding cable-management arm.
- When you attach the cable to a device on slide rails, leave enough slack in the cable so that it does not bend to a radius of less than 38 mm (1.5 in.) when the device is extended or become pinched when the device is retracted.
- Route the cable away from places where it can be snagged by other devices in the rack.
- Do not overtighten the cable straps or bend the cables to a radius of less than 38 mm (1.5 in.).
- Do not put excess weight on the cable at the connection point. Make sure that the cable is well supported.

To connect the fiber-optic cable to the SFP+ module, complete the following steps.

1. Remove the protective caps from the end of the fiber optic cable.

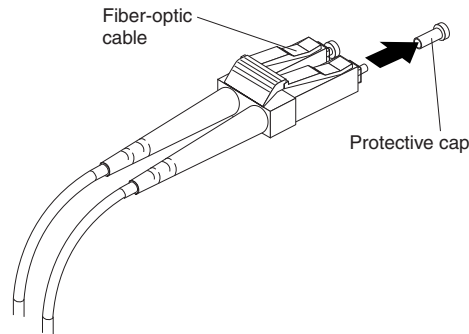

2. Gently slide the fiber optic cable into the SFP+ module until it clicks into place.
3. Check the LEDs on the switch. When the switch is operating correctly, the green link LED is lit. For information about the status of the switch LEDs, see [“Locating the Information Panels, LEDs, and External Ports” on page 32](#).

Disconnecting a Fiber Optic Cable

To disconnect the fiber optic cable from an SFP+ module, complete the following steps:

1. Squeeze the release tabs and gently pull the fiber optic cable from the module.
2. Replace the protective caps on the ends of the fiber optic cable.

Removing an SFP+ Module

To remove the SFP+ module, complete the following steps.

1. Read the safety information that begins on [page 5](#) and “[Installation Guidelines](#)” on [page 18](#).
2. Read the information in “[Handling Transceiver Modules](#)” on [page 25](#).
3. Remove the fiber optic cable from the module that you want to replace. For more information about removing the cable, see “[Disconnecting a Fiber Optic Cable](#)” on [page 27](#).

Attention: To avoid damage to the cable or the SFP+ module, make sure that you remove the fiber-optic cable before you remove the module from the switch port.

4. Unlock the SFP+ module by pulling the wire tab straight out, as shown in the following illustration.

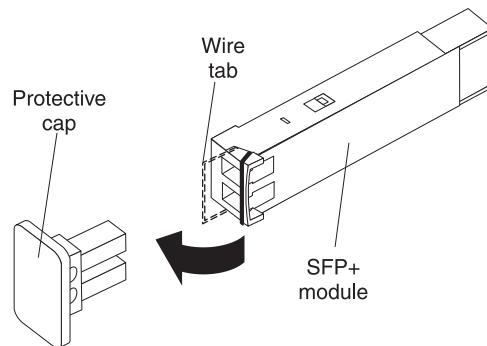

5. Grasp the wire tab on the module and pull it out of the switch port.
6. Replace the protective caps on the module and the switch SFP+ port.
7. Place the module into a static-protective package.

QSFP+ Ports

The QSFP+ ports accept supported QSFP+ modules. The QSFP+ module provides an MTP cable connector for connecting to external devices.

Installing a QSFP+ Module

To install a QSFP+ module in a QSFP+ port on the switch, complete the following steps.

Note: To avoid damage to the cable or the QSFP+ module, do not connect the cable before the QSFP+ module is installed in the switch port.

1. Remove the safety cap from the module and pull the locking lever into the down (unlocked) position.
2. Insert the QSFP+ module into the switch QSFP+ port until it clicks into place. Use minimal pressure when you insert the module into the port. Do not use excessive force when you insert the module; you can damage the module or the QSFP+ port.

The module has a mechanical guide key to prevent you from inserting the module incorrectly.

3. Pull up the locking lever to lock the module into place.
4. Connect the fiber-optic cable.

Connecting a Fiber Optic Cable

Attention: To avoid damage to the fiber optic cables, follow these guidelines:

- Do not route the cable along a folding cable-management arm.
- When you attach the cable to a device on slide rails, leave enough slack in the cable so that it does not bend to a radius of less than 38 mm (1.5 in.) when the device is extended or become pinched when the device is retracted.
- Route the cable away from places where it can be snagged by other devices in the rack.
- Do not overtighten the cable straps or bend the cables to a radius of less than 38 mm (1.5 in.).
- Do not put excess weight on the cable at the connection point. Make sure that the cable is well supported.

To connect the fiber optic cable to the QSFP+ module, complete the following steps.

1. Remove the protective caps from the end of the fiber optic cable.

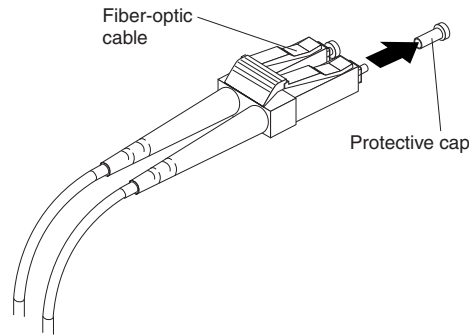

2. Gently slide the fiber optic cable into the QSFP+ module until it clicks into place.
3. Check the LEDs on the switch. When the switch is operating correctly, the green link LED is lit. For information about the status of the switch LEDs, see [“Locating the Information Panels, LEDs, and External Ports”](#) on page 32.

Disconnecting a Fiber Optic Cable

To disconnect the fiber optic cable from the QSFP+ module, complete the following steps:

1. Squeeze the release tabs and gently pull the fiber optic cable from the module.
2. Replace the protective caps on the ends of the fiber optic cable.

Removing a QSFP+ Module

To remove the QSFP+ module from the switch port, complete the following steps.

1. Read the safety information that begins on [page 5](#) and [“Installation Guidelines”](#) on [page 18](#).
2. Read the information in [“Handling Transceiver Modules”](#) on [page 25](#).
3. Remove the fiber optic cable from the module that you want to replace. For more information about removing the cable, see [“Disconnecting a Fiber Optic Cable”](#) on [page 30](#).

Attention: To avoid damage to the cable or the module, make sure that you disconnect the fiber-optic cable before you remove the QSFP+ module from the switch port.

4. Unlock the module by pulling the wire tab straight out, as shown in the following illustration.

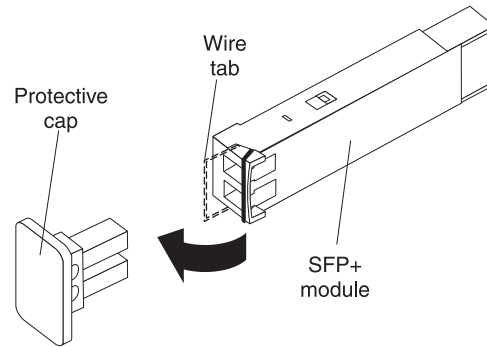

5. Grasp the wire tab on the module and pull it out of the port.
6. Replace the protective cap on the module and the switch QSFP+ port.
7. Place the module into a static-protective package.

Locating the Information Panels, LEDs, and External Ports

This section describes the information panels and LEDs on the switch and identifies the external ports on the information panels.

Note: The illustrations in this document might differ slightly from your hardware.

Information Panel

The front panel of the switch contains a variety of ports and information LEDs.

The switch-module information panel contains the following components.

- LEDs that display the following information:
 - The status of the switch (Power, Locator, and Error)
 - The status of the external connections to the switchFor further details about LEDs, see [“Information LEDs” on page 34](#).
- Fourteen 10 GbE SFP+ port connectors for SFP+ modules or DACs. These connectors are identified as ports EXT1 through EXT14 in the I/O-module configuration menus and are labeled 1 through 14 (from top to bottom) on the switch.
- Two 40 GbE QSFP+ port connectors that can be used as eight 10GbE SFP+ ports. These connectors are identified as ports EXT15 and EXT19 (or EXT15 through EXT18, and EXT19 through EXT22, depending on configuration) in the I/O-module configuration menus, and are labeled 15 through 22 (from top to bottom) on the switch.
- One 9600 baud RS-232 serial port connector for switch console (management) purposes. This connector is located near the bottom of the switch panel, just above the management (Mgmt) port. Do not attach any devices to this connector other than the serial access cable option specified for the switch.
- One 1 Gb Ethernet RJ-45 port connector for switch management purposes. Do not attach any devices to this connector other than when using an industry standard CAT5 cable. This connector is identified as port EXTM in the I/O-module configuration menus and is labeled Mgmt on the switch.

For additional details, see [“Connecting Switch Ports” on page 23](#) and [“Port Status LEDs” on page 35](#).

Figure 4. The EN4093R front panel

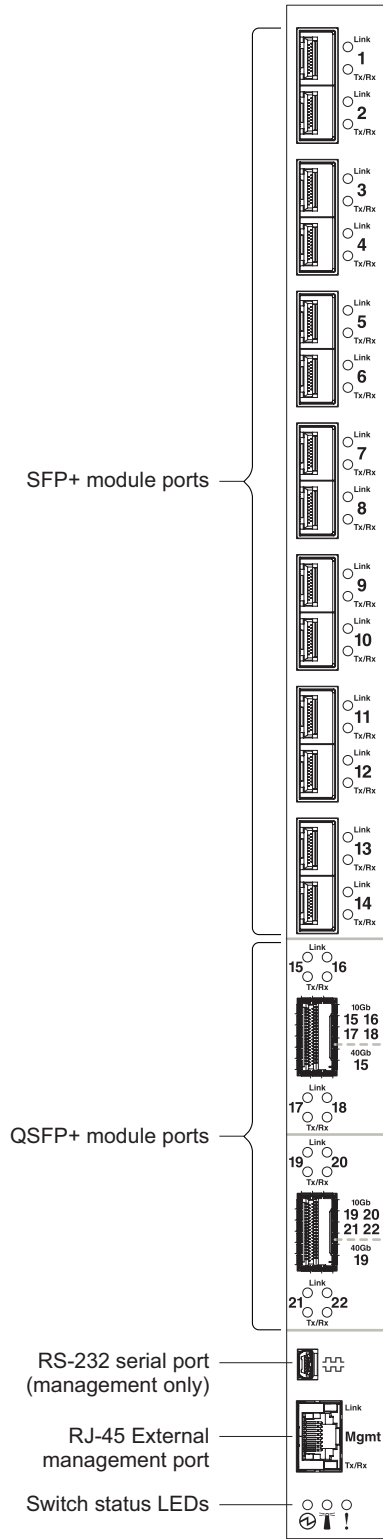

Information LEDs

The front panel of the switch has LEDs for system and port status. The Power, Locator, and Error LEDs indicate the switch status. The Link (LINK) and Activity (TX/RX) LEDs indicate the status of the external ports.

Notes:

- A yellow LED on the Lenovo Flex System chassis is lit when a system error or event has occurred. To identify the error or event, check the Lenovo Flex System management-module event log or the switch system log.
- During POST, the switch Power LED continuously flashes. Additionally, all of the switch status LEDs and the licensed Port LEDs are lit as a visual indication they are working. Once POST has successfully completed, the switch Power LED remains on and the switch Error LED is off.

Any errors that are detected during POST are written to the system log. For information about the command to read the system log, see the *Command Reference* for the switch.

When POST errors are written to the system log, these errors are also written to the Lenovo Flex System management-module event log. If a hardware error, such as a current fault occurs, the CMM displays it. If a firmware error occurs, the CMM displays the `Module did not complete POST` message and a post error code that indicates the test that was running when the error was detected.

Note: You can also use the CMM to make sure that the switch is operating correctly. For more information, see the CMM documentation.

Switch Status LEDs

The following table provides descriptions of the switch status LEDs on the front panel of the switch.

Table 3. *System status LEDs behavior*

LED	State	Functional Meaning
Ⓢ - Power	Steady green	When lit, this LED indicates that the switch is on.
	Off	When this LED is off and the yellow Error LED is lit, it indicates a critical alert. If both the Power and Error LEDs are off, it indicates that the switch is off.
📍 - Locator	Steady blue	When prompted by a user action in the CMM, this LED is lit to help identify the location of the switch.
	Off	The switch has not received a user-prompted locator command from the CMM.
! - Error	Steady yellow	When lit, this LED indicates a POST failure or critical alert. As a result, the system-error LED on the Lenovo Flex System chassis is also lit.
	Off	When this LED is off and the green Power LED is lit, it indicates that the switch is working correctly. If both the Power and Error LEDs are off, it indicates that the switch is off.

Port Status LEDs

The following table provides descriptions of the port status LEDs on the front panel of the switch.

Table 4. *System status LEDs behavior*

LED	State	Functional Meaning
Link	Steady green	A connection (or link) is established between the corresponding port and the attached device.
	Off	There is no signal on the corresponding port, or the link is down.
Tx/Rx	Flashing green	The corresponding port link is transmitting and/or receiving.
	Off	There is currently no traffic on the port.

Chapter 3. Configuring the EN4093R

The switch has an internal Ethernet path to the Chassis Management Module (CMM), the external Ethernet data ports, an external management port, and a serial console port. The switch supports two remote-access modes for management through Ethernet connections. You can select the mode that is best suited for your Lenovo Flex System environment.

- **Default mode:** The default mode uses the internal path to the CMM only. In this mode, the remote-access link to the management console must be attached to the Ethernet connector on the CMM. The Internet Protocol (IP) addresses and Simple Network Management Protocol (SNMP) parameters of the switch can be automatically assigned by the Lenovo Director Flex System Deployment wizard (when available), or you must assign them through the Lenovo Flex System Management and Configuration program. This mode enables you to provide a secure LAN for management of the Lenovo Flex Systems subsystems that is separate from the data network. See [“Establishing an Interface Through the CMM” on page 39](#) for more information.
- **External management mode:** External management mode allows for the use of alternate management entities to control and configure the switch. You must enable external management in order to manage the switch using the dedicated external management port (EXTM) or any of the external data ports (EXT1-EXT22, in-band switch management). This mode can be used instead of or in addition to access through the CMM. This mode can be enabled only through the CMM configuration interface. When this mode is enabled, the external ports support both management and data traffic.

This mode enables the use of additional switch IP addresses on different IP subnets than the CMMs. This is useful when the switches are to be managed and controlled as part of the overall network infrastructure, while secure management of other Lenovo Flex System subsystems is maintained through the CMM. See [“Enabling Management Through Data Ports” on page 40](#) for additional instructions about configuring the switch for this mode of operation.

The RS-232 console port provides an alternative path to manage and configure the switch for local access.

Important:

- Before you configure the switch, make sure that the CMM is correctly configured. For more information about configuring the CMM, see the following documents:
 - *Lenovo Flex System Chassis Management Module Installation Guide*
 - *Lenovo Flex System Chassis Management Module User’s Guide*
- The initial default IP address assigned to the switch by the CMM is 192.168.70.120, 192.168.70.121, 192.168.70.122, or 192.168.70.123 depending on the bay where the switch is installed.
- If you change the IP address of the switch and restart the Lenovo Flex System chassis, the switch maintains this new IP address as its default value.
- The CMM and the switch can communicate with each other only if they are on the same IP subnet.

- When configuring the switch, you must execute the `copy running-config startup-config` command if you want the configuration change to persist beyond the next reboot of the switch. This command stores the current switch configuration and all changes in nonvolatile memory.

If the switch restarts and the CMM cannot apply the saved configuration, the switch defaults to the configuration that was previously saved. If the IP subnet address of the switch does not match the IP subnet address of the CMM, you can no longer manage the switch from the CMM. For more information about configuring the switch, see the *Command Reference* for your specific switch and its installed firmware.

- When you use the management-module Web interface to update the switch configuration, the management-module firmware saves the new configuration in internal nonvolatile memory. If the switch restarts, the CMM applies the saved configuration to the switch. For more information, see the *Application Guide* and the *Command Reference* for your specific switch and its installed firmware.
- For switch communication with a remote management station, such as an Lenovo Director management server, through the management-module external Ethernet port, the switch internal-network interface and the management-module external interface must be on the same IP subnet.

For specific details about configuring the switch and preparing for system installation, see the documentation listed in [“Related Documentation” on page 13](#).

Notes:

- Unless otherwise stated, references to the CMM apply only to the Lenovo Flex System Chassis Management Module, which is the only type of management module that supports the switch.
- Throughout this document, the management-module Web-based user interface is also known as the Lenovo Flex System management-module Web interface.
- Throughout this document, the user name is also known as the login name or user ID for logging on to interfaces or programs.
- The screens that are described or referenced in this document might differ slightly from the screens that are displayed by your system. Screen content varies according to the type of Lenovo Flex System chassis and the firmware versions and options that are installed.

Establishing an Interface Through the CMM

For remote management functions, the switch requires a TCP/IP interface. This can be configured through the CMM as follows:

1. Log on to the CMM Command-Line Interface (CLI) as described in the CMM documentation. If necessary, obtain the IP address of the CMM from your system administrator.

Note: The default User ID for the CMM is **USERID**, and the default password is **PASSW0RD** (where the sixth character is the number zero, not the letter O). The User ID and password fields are case-sensitive.

2. Set the environment to the bay where you installed the switch:

```
system> env -T system:switch[1]
```

3. Execute the `ifconfig` command to configure the IP parameters you wish to use for remote switch management. For example,

```
ifconfig -i 192.168.70.1 -s 255.255.255.0 -g 192.168.70.100
```

where the `-i` parameter is the IPv4 address, `-s` is the subnet mask, and `-g` is the default gateway.

4. You should now be able to ping the switch from the CMM using this address:

```
system:switch[1]> ping -i 192.168.70.1
Reply from 192.168.70.1: bytes=64 time=0.198ms
Reply from 192.168.70.1: bytes=64 time=0.213ms
Reply from 192.168.70.1: bytes=64 time=0.228ms
Reply from 192.168.70.1: bytes=64 time=0.168ms
```

Once the switch management address is configured, you can use it to establish a Secure Shell (SSH)/Telnet session or Web session (HTTPS/HTTP).

Note: SSH and HTTPs are enabled by default. Telnet and HTTP can be enabled once you have initially logged into the switch.

The Web interface application and the SSHv2/Telnet client software provide different ways to access the same internal-switching firmware and configure it.

If your system application requires that you use the Web interface application, see [“Accessing the Switch Through the Browser-Based Interface” on page 43](#) for additional information.

If your system application requires that you use the SSHv2/Telnet client software, see [“Accessing the Switch Through the SSHv2/Telnet Interface” on page 41](#) for additional information.

Enabling Management Through Data Ports

To access and manage the switch through external interfaces, you must enable the data (non-management) ports and the ability to manage the switch through them. Use the information in the following table to configure your ports.

Data Ports (-ep option)	External Mgmt (-em option)	Description
Disabled	Disabled	The switch must be managed through the CMM. No traffic is allowed on internal or external switch ports.
Enabled	Disabled	The switch must be managed through the CMM. Data traffic is allowed on internal and external switch ports.
Disabled	Enabled	The switch can be managed through the CMM or a compute node. No traffic is allowed on internal or external switch ports.
Enabled	Enabled	The switch can be managed through the CMM, a compute node, or a management station that is connected through the switch. Data traffic is allowed on internal and external switch ports.

To enable management through data ports, complete the following steps:

1. Log on to the CMM CLI as described in the CMM documentation. If necessary, obtain the IP address of the CMM from your system administrator.
2. Set the environment to the bay where you installed the switch:

```
system> env -T system:switch[1]
```

3. Execute the `ifconfig` command to enable data ports and external management:

```
ifconfig -ep enabled -em enabled
```

4. You should now be able to manage the switch using its data ports or external management port.

Note: “External management” refers to means other than by the CMM. To externally manage the switch, additional IP interfaces must be configured. For more information see the *Application Guide* for your specific switch and its installed firmware.

Accessing the Switch Through the SSHv2/Telnet Interface

The switch supports a Command-Line Interface (CLI) that you can use to configure and control the switch over the network through the SSHv2/Telnet client software. You can use the CLI to perform many basic network-management functions. In addition, you can configure the switch for management through an SNMP-based network-management system.

If you know the IP address for the switch ([“Establishing an Interface Through the CMM” on page 39](#)) and you have an existing network connection, you can use the SSHv2/Telnet client software from an external management station to access and control the switch. Optimally, the management station and the switch should be on the same subnet. Otherwise, you must use a router and configure a gateway address on the switch. If you have to obtain the IP address for the switch or establish a network connection, contact your system or network administrator.

The switch also supports user-based security that enables you to prevent unauthorized users from accessing the switch or changing its settings.

To connect to the switch through the SSHv2/Telnet interface, refer to your client software for specific instructions on how to invoke a session. For example, using the Microsoft Telnet Client, you would complete the following steps:

1. From a DOS command-line prompt, type **telnet** <switch IP address> and press Enter.
2. When prompted, enter your user name and password.
 - o When logging in to a switch for the first time, the default switch administrator user name is **USERID**, and the default password is **PASSWORD** (where the sixth character is the number zero, not the letter O). The User ID and password fields are case-sensitive. For security purposes, you will be prompted to change the administrator password after the first successful login.
 - o Otherwise, if you have an assigned user account, use your assigned user name and password.

Important: Any configuration changes made using the management interfaces will be lost during the next switch reboot unless you execute the `copy running-config startup-config` command. This command stores the current switch configuration and all changes in nonvolatile memory.

For more information about configuring through the CLI, see the *Application Guide* and *Command Reference* for your specific switch and its installed firmware.

Accessing the Switch Through the Serial-Port Interface

The serial port provides basic communication RS-232 serial-data transfer through a terminal emulation program (such as Hyperterminal). Because messages from the power-on self-test (POST) and all initialization information are transmitted through the serial port, you can use the serial port to log in to the switch and access and configure the internal switching firmware.

To log in to the switch, complete the following steps:

1. Connect one end of the specifically designed serial cable that comes with your device into the RS-232 port and connect the other end to the management station.
For additional information, see [“Connecting the Serial Console Cable” on page 23](#).
2. On the management station, open a console window and make sure that the serial port is configured with the following settings:
 - o 9600 baud
 - o 8 data bits
 - o No parity
 - o 1 stop bit
 - o No flow control
3. When prompted, enter your user name and password.
 - o When logging in to a switch for the first time, the default switch administrator user name is **USERID**, and the default password is **PASSW0RD** (where the sixth character is the number zero, not the letter O). The User ID and password fields are case-sensitive. For security purposes, you will be prompted to change the administrator password after the first successful login.
 - o Otherwise, if you have an assigned user account, use your assigned user name and password.

The serial port is compatible with the standard 16550 Universal Asynchronous Receiver/Transmitter (UART) protocol. The RS-232 serial port is enabled by default.

Accessing the Switch Through the Browser-Based Interface

Before you can access and start the browser-based interface, make sure that you have completed the following procedures:

- Configure at least one IP interface on the switch. Refer to [“Establishing an Interface Through the CMM” on page 39](#) for more information.
- Enable frames and the JavaScript program in your Web browser.

The following hardware and software are required for the Web interface:

- A frame-capable Web-browser program, such as Internet Explorer (version 7.0 or later), Mozilla Firefox (version 8.0 or later), or Google Chrome (version 16.0 or later)
- A computer or workstation with network access to the switch

To start the browser-based interface, complete the following steps:

1. Start a Web browser. The Web-browser window opens.
2. In the **URL** field, enter the IP address of the switch, in the following format:
https://xxx.xxx.xxx.xxx.
The login window opens.
3. When prompted, enter your user name and password and click **OK**.
 - o When logging in to a switch for the first time, the default switch administrator user name is **USERID**, and the default password is **PASSWORD** (where the sixth character is the number zero, not the letter O). The User ID and password fields are case-sensitive. For security purposes, you will be prompted to change the administrator password after the first successful login.
 - o Otherwise, if you have an assigned user account, use your assigned user name and password.

Initial Configuration

The operating firmware on the switch contains default configuration files that are installed during the firmware installation. These initial configuration settings are not in a separate configuration file but are components of the firmware. When you restore the switch to factory defaults, the original configuration is restored.

After you log on to the switch, you must perform basic configuration tasks. For more information about configuring and managing the switch, see the *Application Guide* and *Command Reference* for your specific switch and its installed firmware.

Chapter 4. Updating the Firmware and Licensing

This chapter describes how to determine the level of the firmware that is installed on the switch, how to obtain the latest level of switch firmware, how to upgrade the firmware, how to acquire additional feature licenses, and how to reset the switch to activate the firmware upgrade.

Note: Configuration settings may be lost during some firmware updates. Before updating the firmware, save a copy of the configuration on a separate device. In the event of a failed update, the saved configuration can be restored. For more information about the configuration file, see the *Application Guide* and *Command Reference* for your specific switch and installed firmware.

Determining the Level of Switch Firmware

After you install the switch in the Lenovo Flex System chassis, make sure that the latest firmware is installed on the switch. To determine the level of the firmware that is installed, complete the following steps.

1. Log on to the Lenovo Flex System Chassis Management Module (CMM) Command-Line Interface (CLI) as described in the CMM documentation. If necessary, obtain the Internet Protocol (IP) address of the CMM from your system administrator.
2. Set the environment to the bay where you installed the switch. For example:

```
system> env -T system:switch[1]
```

3. Execute the **info** command to display switch firmware information:

```
system:switch[1]> info
...
Boot ROM
    Rel date: 04/02/2013
    Version: 7.7.1.12
    Status: Active
Main application
    Rel date: 04/02/2013
    Version: 7.7.1.12
    Status: Active
Main application
    Rel date: 03/22/2013
    Version: 7.7.1.12
    Status: Inactive
```

Obtaining the Latest Level of Switch Firmware

If firmware updates are available, you can download them from the Lenovo website:

<http://support.lenovo.com/>

Note: Changes are made periodically to the Lenovo website. Procedures for locating firmware and documentation might vary slightly from what is described in this document.

Attention:

- Before updating the firmware, save a copy of the configuration to a separate device. In the event of a failed update, the saved configuration can be restored. For more information about the configuration file, see the *Application Guide* and *Command Reference* for your specific switch and firmware version.
- Installing the incorrect firmware might cause the switch to malfunction. Before you install firmware, read any release notes, readme files and change history files that are provided with the downloaded update. These files contain important information about the update and the procedure for installing the update, including any special procedure or requirements for updating from an early firmware version to the latest version.

Upgrading the Switch Firmware

You can upgrade the switch firmware by using an FTP, TFTP or SFTP file server. Typically, the file server runs as an application under your operating system. Make sure that the file server application is installed on your file server; then, download the switch firmware images from the Lenovo website into a directory on your file server. Then enable the file server and set its default directory to the directory where the switch firmware image resides.

Note: Updating the firmware involves rebooting the switch. If you have made any configuration changes you wish to persist beyond the upgrade process, you must type the `copy running-config startup-config` command. This command stores the current switch configuration and all changes to nonvolatile memory.

To transfer the switch firmware image files from the FTP, TFTP or SFTP file server to the switch, you can establish a Secure Shell (SSH) v2 or Telnet session through the CMM. Ping the file server to make sure that you have a connection. The session performs optimally if all three network entities (file server, CMM, and switch IP addresses) are on the same subnet. Otherwise, you must use a router and configure a gateway address on the switch. Use the management-module interface to configure the IP addresses of the CMM external interface (eth0) and the switch so that they are both on the same subnet as the file server.

Examples of IP addresses and masks are described in the following table.

Network entity	IP address	Mask
FTP, TFTP or SFTP file server	192.168.2.178	255.255.255.0
CMM (eth0)	192.168.2.237	255.255.255.0
Switch-module current IP configuration (IF 128)	192.168.2.51	255.255.255.0

Note: With this configuration, you can ping the switch from the file server.

Switch Firmware Upgrade Example

To upgrade the switch firmware, complete the following steps.

1. Log in to the switch (see [“Configuring the EN4093R” on page 37](#) for more information).
2. At the switch Command-Line Interface (CLI) prompt, execute the following commands to upload the firmware image to the switch.

```
EN 4093> enable
EN 4093# copy {ftp|tftp|sftp} {image1|image2} addr <server address> file
<image file> {data-port|extm-port|mgt-port}
```

Where *server address* is the IP address of file server, and *image file* is the file name of the firmware image as it appears in the file server operating-system.

3. Execute the following command to upload the boot image to the switch.

```
EN 4093# copy {ftp|tftp|sftp} boot addr <server address> file <boot file>
{data-port|extm-port|mgt-port}
```

Where *boot file* is the file name of the boot image as it appears in the file server operating-system.

4. Reset and restart the switch as described in [“Resetting and Restarting the Switch” on page 50](#).

Resetting and Restarting the Switch

To activate the new image or images, you must reset the switch. To reset the switch, complete the following steps:

1. Log on to the CMM CLI as described in the CMM documentation. If necessary, obtain the IP address of the CMM from your system administrator.
2. Set the environment to the bay where you installed the switch. For example:

```
system> env -T system:switch[1]
```

3. Execute the **reset** command to restart the switch:

```
system:switch[1]> reset
```

4. Wait for the POST to complete. This may take up to 2 minutes.
5. Execute the **info** command for the switch that was just restarted and note the corresponding level of the firmware for the switch. Confirm that the firmware build number reflects the correct firmware release. For example:

```
system:switch[1]> info
...
Boot ROM
  Rel date: 01/18/2015
  Version: 7.11.0.0
  Status: Active
Main application
  Rel date: 01/18/2015
  Version: 7.11.0.0
  Status: Active
Main application
  Rel date: 01/18/2015
  Version: 7.11.0.0
  Status: Inactive
```

Acquiring Feature Licenses

The base option for EN4093R supports twenty-four total data ports (fourteen compute node ports and ten uplink ports). Licenses are available that enable the use of additional ports on the switch:

- Upgrade 1—This upgrade feature adds fourteen internal ports (15–28) and two external 40 Gigabit Ethernet (GbE) ports (57 and 61). If ports EXT15 and EXT19 are configured for 10 GbE, then ports 57 through 64 are enabled.
- Upgrade 2—This upgrade feature option adds fourteen internal ports (29–43) and four external 10 GbE ports (53–56) to the Upgrade 1 feature.

Note: Upgrade 1 is a prerequisite to Upgrade 2.

Upgrade licenses are unique to each switch and are non transferable.

To acquire an upgrade license activation key, purchase the Authorization Code and locate the unique ID (UID) on the switch serial number (SN) label (bottom or rear of switch module). The UID is the last twelve characters of the switch serial number. This serial number is located on the part number (PN) label (bottom or rear of switch module) and is also displayed during a login to any of the user interfaces. For example, SN (UID): Y250CM294998. For more information about locating the switch identification labels, see [“Before Installing the EN4093R” on page 17](#).

In the event of the switch replacement, new activation key files based on the serial number of the replacement unit must be acquired and installed. If the replacement is handled through Lenovo Service and Support, your original Authorization Code is transferred to the serial number of the replacement unit.

You can use the Lenovo website to perform the following tasks:

- Request a new activation key
- Check an authorization code to see what feature it enables and how many remaining times it can be used to create a key
- Retrieve the history of feature activation on a selected device
- Retrieve the history of feature activation on a selected authorization code
- Retrieve a lost authorization code
- Manage your Lenovo customer number
- Find help for the Features on Demand feature activation process
- Provide feedback to Lenovo about the Features on Demand process

Note: Your Lenovo ID and password are required to log into the Features on Demand website.

Installing Feature Licenses

Once Features on Demand activation key files have been acquired, they must be installed on the switch. The example below illustrates use of the switch CLI, but other interfaces may also be used, such as the Browser Based Interface (BBI), or Simple Network Management Protocol (SNMP). For more information, see the *Application Guide* and *Command Reference* for your specific switch and its installed firmware.

When installing licenses, please note the following requirements:

- A switch reboot is required to fully activate the license(s). If you have made any configuration changes you wish to persist beyond the reboot, you must execute the `copy running-config startup-config` command. This command stores the current switch configuration and all changes to nonvolatile memory.
- Both license key files can be installed prior to the switch reset in order to activate both at the same time.

Complete the following steps to install feature licenses:

1. Log in to the switch (see [“Configuring the EN4093R” on page 37](#) for more information).
2. At the switch CLI prompt, type the following command.

```
EN 4093> enable
EN 4093# software-key
EN 4093(Software-Key)# enakey addr <server address> keyfile <file name> protocol
{tftp|sftp} {data-port|extm-port|mgt-port}
```

where *server address* is the IP address of the TFTP or SFTP file server, and *file name* is the name of the licence key file as it appears in the file server operating system.

3. Once the key file transfer is complete, reset the switch to activate the license(s) (see [“Resetting and Restarting the Switch” on page 50](#)).

Chapter 5. Solving Problems

This section provides basic troubleshooting information to help you solve some problems that might occur while you are setting up the switch. The *Application Guide* for the switch provides more details about troubleshooting the switch.

If you cannot locate and correct a problem by using the information in this section, see [“Getting Help and Technical Assistance” on page 57](#).

Running POST

To ensure that it is fully operational, the switch processes a series of tests during power-up or a restart (Power-On Self-Test, or POST). These tests may take up to two minutes to complete. The Lenovo Flex System Chassis Management Module (CMM) reads the test results and displays them for you. During normal operation, these tests are completed without error, and the green switch Power LED is lit. However, if the switch fails POST, the yellow Error LED on the switch and the system-error LED on the chassis are lit. An event is stored in the event log in the system status panel of the CMM. The specific failure is displayed on the system status I/O module panel of the CMM.

Note: For the locations and descriptions of the switch LEDs, see [“Locating the Information Panels, LEDs, and External Ports”](#) on page 32.

POST Errors

There are two types of errors: noncritical and critical. A noncritical error applies to one port, and the switch is operational. You can continue to operate the switch; however, you must replace it as soon as possible. When critical errors occur, the switch does not operate.

To view POST results, complete the following steps:

1. Log on to the CMM Command-Line Interface (CLI) as described in the CMM documentation. If necessary, obtain the Internet Protocol (IP) address of the CMM from your system administrator. The login window opens.
2. Turn off the power to the switch; then, turn it on again.
3. After POST is completed, the CMM displays the results. Refresh the window to view the POST results. If a critical error occurs, replace the switch. If a noncritical error occurs, see the switch error log for additional details.

The following table describes the basic critical and noncritical failures. This abbreviated list is representative; it is not an exhaustive list. An error code is associated with each failure. Error codes are displayed on the CMM Switch Information window. Be sure to note the applicable error code and corresponding failure. You might have to provide this information when you call for service. For details, see [“Getting Help and Technical Assistance” on page 57](#).

Diagnostic indicator (in hex)	Failing functional area	Failure criticality
00–7F	Base internal functions	Critical
80–9F	Internal interface failures	Noncritical
A0–AF	External interface errors	Noncritical
B0–FE	Reserved	Noncritical
FF	Switch “good” indicator	Operation

Parts listing

The following replaceable components are available for the Lenovo Flex System network devices.

Replaceable components are of three types:

- **Tier 1 customer replaceable unit (CRU):** Replacement of Tier 1 CRUs is your responsibility. If Lenovo installs a Tier 1 CRU at your request, you will be charged for the installation.
- **Tier 2 customer replaceable unit (CRU):** You may install a Tier 2 CRU yourself or request Lenovo to install it, at no additional charge, under the type of warranty service that is designated for your server.
- **Field replaceable unit (FRU):** FRUs must be installed only by trained service technicians.

For information about the terms of the warranty, see the *Warranty Information* document.

The replaceable components in the following table are Tier 1 CRUs. If other components require replacement, see the documentation that came with those devices for instructions.

The following table lists the replaceable components.

Description	CRU part number (Tier 1)
Lenovo Flex System Fabric EN4093R 10Gb Scalable Switch	00VX205

Appendix A. Getting Help and Technical Assistance

If you need help, service, or technical assistance or just want more information about Lenovo products, you will find a wide variety of sources available from Lenovo to assist you. This appendix will help you obtain additional information about Lenovo and Lenovo products, and determine what to do if you experience a problem with your Lenovo system or optional device.

Note: This section includes references to IBM web sites and information in regard to obtaining service. IBM is Lenovo's preferred service provider for the System x, Flex System, and NeXtScale System products.

You can solve many problems without outside assistance by following the troubleshooting procedures that Lenovo provides in the online help or in the Lenovo product documentation. The Lenovo product documentation also describes the diagnostic tests that you can perform. The documentation for most systems, operating systems, and programs contains troubleshooting procedures and explanations of error messages and error codes. If you suspect a software problem, see the documentation for the operating system or program.

Before you call, make sure that you have taken these steps to try to resolve the problem yourself.

- Check all cables to make sure that they are connected.
- Check the power switches to make sure that the system and any optional devices are turned on.
- Check for updated software, firmware and operating-system device drivers for your Lenovo product. The Lenovo Warranty terms and conditions state that you, the owner of the Lenovo product, are responsible for maintaining and updating all software or firmware for the product (unless it is covered by an additional maintenance contract). Your service technician will request that you upgrade your software or firmware if the problem has a documented solution within a software or firmware upgrade.
- If you have installed new hardware or software in your environment, check the [IBM ServerProven website](#) to make sure that the hardware and software is supported by your product.
- Go to the [IBM Support portal](#) to check for information to help you solve the problem, and for other support options.

- If you believe that you require warranty service for your Lenovo product, gather the following information to provide to the service technician. This data will help the service technician quickly provide a solution to your problem and ensure that you receive the level of service for which you might have contracted. The service technicians will be able to assist you more efficiently if you prepare before you call.
 - Hardware and Software Maintenance agreement contract numbers, if applicable
 - Model number
 - Serial number
 - Current system UEFI and firmware levels
 - Other pertinent information such as error messages and logs

Appendix B. Notices

Lenovo may not offer the products, services, or features discussed in this document in all countries. Consult your local Lenovo representative for information on the products and services currently available in your area.

Any reference to a Lenovo product, program, or service is not intended to state or imply that only that Lenovo product, program, or service may be used. Any functionally equivalent product, program, or service that does not infringe any Lenovo intellectual property right may be used instead. However, it is the user's responsibility to evaluate and verify the operation of any other product, program, or service.

Lenovo may have patents or pending patent applications covering subject matter described in this document. The furnishing of this document does not give you any license to these patents. You can send license inquiries, in writing, to:

Lenovo (United States), Inc.
1009 Think Place - Building One
Morrisville, NC 27560
U.S.A.

Attention: Lenovo Director of Licensing

LENOVO PROVIDES THIS PUBLICATION "AS IS" WITHOUT WARRANTY OF ANY KIND, EITHER EXPRESS OR IMPLIED, INCLUDING, BUT NOT LIMITED TO, THE IMPLIED WARRANTIES OF NON-INFRINGEMENT, MERCHANTABILITY OR FITNESS FOR A PARTICULAR PURPOSE. Some jurisdictions do not allow disclaimer of express or implied warranties in certain transactions, therefore, this statement may not apply to you.

This information could include technical inaccuracies or typographical errors. Changes are periodically made to the information herein; these changes will be incorporated in new editions of the publication. Lenovo may make improvements and/or changes in the product(s) and/or the program(s) described in this publication at any time without notice.

The products described in this document are not intended for use in implantation or other life support applications where malfunction may result in injury or death to persons. The information contained in this document does not affect or change Lenovo product specifications or warranties.

Nothing in this document shall operate as an express or implied license or indemnity under the intellectual property rights of Lenovo or third parties. All information contained in this document was obtained in specific environments and is presented as an illustration. The result obtained in other operating environments may vary.

Lenovo may use or distribute any of the information you supply in any way it believes appropriate without incurring any obligation to you.

Any references in this publication to non-Lenovo Web sites are provided for convenience only and do not in any manner serve as an endorsement of those Web sites. The materials at those Web sites are not part of the materials for this Lenovo product, and use of those Web sites is at your own risk.

Any performance data contained herein was determined in a controlled environment. Therefore, the result obtained in other operating environments may vary significantly. Some measurements may have been made on development-level systems and there is no guarantee that these measurements will be the same on generally available systems. Furthermore, some measurements may have been estimated through extrapolation. Actual results may vary. Users of this document should verify the applicable data for their specific environment.

Trademarks

Lenovo, the Lenovo logo, Flex System, System x, NeXtScale System, and X-Architecture are trademarks of Lenovo in the United States, other countries, or both.

Intel and Intel Xeon are trademarks of Intel Corporation in the United States, other countries, or both.

Internet Explorer, Microsoft, and Windows are trademarks of the Microsoft group of companies.

Linux is a registered trademark of Linus Torvalds.

Other company, product, or service names may be trademarks or service marks of others.

Important Notes

Processor speed indicates the internal clock speed of the microprocessor; other factors also affect application performance.

CD or DVD drive speed is the variable read rate. Actual speeds vary and are often less than the possible maximum.

When referring to processor storage, real and virtual storage, or channel volume, KB stands for 1 024 bytes, MB stands for 1 048 576 bytes, and GB stands for 1 073 741 824 bytes.

When referring to hard disk drive capacity or communications volume, MB stands for 1 000 000 bytes, and GB stands for 1 000 000 000 bytes. Total user-accessible capacity can vary depending on operating environments.

Maximum internal hard disk drive capacities assume the replacement of any standard hard disk drives and population of all hard-disk-drive bays with the largest currently supported drives that are available from Lenovo.

Maximum memory might require replacement of the standard memory with an optional memory module.

Each solid-state memory cell has an intrinsic, finite number of write cycles that the cell can incur. Therefore, a solid-state device has a maximum number of write cycles that it can be subjected to, expressed as total bytes written (TBW). A device that has exceeded this limit might fail to respond to system-generated commands or might be incapable of being written to. Lenovo is not responsible for replacement of a device that has exceeded its maximum guaranteed number of program/erase cycles, as documented in the Official Published Specifications for the device.

Lenovo makes no representations or warranties with respect to non-Lenovo products. Support (if any) for the non-Lenovo products is provided by the third party, not Lenovo.

Some software might differ from its retail version (if available) and might not include user manuals or all program functionality.

Recycling information

Lenovo encourages owners of information technology (IT) equipment to responsibly recycle their equipment when it is no longer needed. Lenovo offers a variety of programs and services to assist equipment owners in recycling their IT products. For information on recycling Lenovo products, go to:

<http://www.lenovo.com/recycling>

Particulate Contamination

Attention: Airborne particulates (including metal flakes or particles) and reactive gases acting alone or in combination with other environmental factors such as humidity or temperature might pose a risk to the device that is described in this document.

Risks that are posed by the presence of excessive particulate levels or concentrations of harmful gases include damage that might cause the device to malfunction or cease functioning altogether. This specification sets forth limits for particulates and gases that are intended to avoid such damage. The limits must not be viewed or used as definitive limits, because numerous other factors, such as temperature or moisture content of the air, can influence the impact of particulates or environmental corrosives and gaseous contaminant transfer. In the absence of specific limits that are set forth in this document, you must implement practices that maintain particulate and gas levels that are consistent with the protection of human health and safety. If Lenovo determines that the levels of particulates or gases in your environment have caused damage to the device, Lenovo may condition provision of repair or replacement of devices or parts on implementation of appropriate remedial measures to mitigate such environmental contamination. Implementation of such remedial measures is a customer responsibility.

Contaminant	Limits
Particulate	<ul style="list-style-type: none"> The room air must be continuously filtered with 40% atmospheric dust spot efficiency (MERV 9) according to ASHRAE Standard 52.2¹. Air that enters a data center must be filtered to 99.97% efficiency or greater, using high-efficiency particulate air (HEPA) filters that meet MIL-STD-282. The deliquescent relative humidity of the particulate contamination must be more than 60%². The room must be free of conductive contamination such as zinc whiskers.
Gaseous	<ul style="list-style-type: none"> Copper: Class G1 as per ANSI/ISA 71.04-1985³ Silver: Corrosion rate of less than 300 Å in 30 days

¹ ASHRAE 52.2-2008 - *Method of Testing General Ventilation Air-Cleaning Devices for Removal Efficiency by Particle Size*. Atlanta: American Society of Heating, Refrigerating and Air-Conditioning Engineers, Inc.

² The deliquescent relative humidity of particulate contamination is the relative humidity at which the dust absorbs enough water to become wet and promote ionic conduction.

³ ANSI/ISA-71.04-1985. *Environmental conditions for process measurement and control systems: Airborne contaminants*. Instrument Society of America, Research Triangle Park, North Carolina, U.S.A.

Telecommunication Regulatory Statement

This product may not be certified in your country for connection by any means whatsoever to interfaces of public telecommunications networks.

Further certification may be required by law prior to making any such connection. Contact a Lenovo representative or reseller for any questions.

Electronic Emission Notices

When you attach a monitor to the equipment, you must use the designated monitor cable and any interference suppression devices that are supplied with the monitor.

Federal Communications Commission (FCC) Statement

Warning: Changes or modifications to this unit not expressly approved by the party responsible for compliance could void the user authority to operate the equipment.

Note: This equipment has been tested and found to comply with the limits for a Class A digital device, pursuant to Part 15 of the FCC Rules. These limits are designed to provide reasonable protection against harmful interference when the equipment is operated in a commercial environment. This equipment generates, uses, and can radiate radio frequency energy and, if not installed and used in accordance with the instruction manual, may cause harmful interference to radio communications. Operation of this equipment in a residential area is likely to cause harmful interference, in which case the user will be required to correct the interference at his own expense.

Properly shielded and grounded cables and connectors must be used in order to meet FCC emission limits. Lenovo is not responsible for any radio or television interference caused by using other than recommended cables and connectors or by unauthorized changes or modifications to this equipment. Unauthorized changes or modifications could void the user's authority to operate the equipment.

This device complies with Part 15 of the FCC Rules. Operation is subject to the following two conditions: (1) this device may not cause harmful interference, and (2) this device must accept any interference received, including interference that may cause undesired operation.

Industry Canada Class A Emission Compliance Statement

This Class A digital apparatus complies with Canadian ICES-003.

Avis de Conformité à la Réglementation d'Industrie Canada

Cet appareil numérique de la classe A est conforme à la norme NMB-003 du Canada.

Australia and New Zealand Class A Statement

Attention: This is a Class A product. In a domestic environment this product may cause radio interference in which case the user may be required to take adequate measures.

European Union - Compliance to the Electromagnetic Compatibility Directive

This product is in conformity with the protection requirements of EU Council Directive 2004/108/EC (until April 19, 2016) and EU Council Directive 2014/30/EU (from April 20, 2016) on the approximation of the laws of the Member States relating to electromagnetic compatibility. Lenovo cannot accept responsibility for any failure to satisfy the protection requirements resulting from a non-recommended modification of the product, including the installation of option cards from other manufacturers.

This product has been tested and found to comply with the limits for Class A equipment according to European Standards harmonized in the Directives in compliance. The limits for Class A equipment were derived for commercial and industrial environments to provide reasonable protection against interference with licensed communication equipment.

 Lenovo, Einsteinova 21, 851 01 Bratislava, Slovakia

Warning: This is a Class A product. In a domestic environment this product may cause radio interference in which case the user may be required to take adequate measures.

Germany Class A Statement

Deutschsprachiger EU Hinweis:

Hinweis für Geräte der Klasse A EU-Richtlinie zur Elektromagnetischen Verträglichkeit

Dieses Produkt entspricht den Schutzanforderungen der EU-Richtlinie 2014/30/EU (früher 2004/108/EC) zur Angleichung der Rechtsvorschriften über die elektromagnetische Verträglichkeit in den EU-Mitgliedsstaaten und hält die Grenzwerte der Klasse A der Norm gemäß Richtlinie.

Um dieses sicherzustellen, sind die Geräte wie in den Handbüchern beschrieben zu installieren und zu betreiben. Des Weiteren dürfen auch nur von der Lenovo empfohlene Kabel angeschlossen werden. Lenovo übernimmt keine Verantwortung für die Einhaltung der Schutzanforderungen, wenn das Produkt ohne Zustimmung der Lenovo verändert bzw. wenn Erweiterungskomponenten von Fremdherstellern ohne Empfehlung der Lenovo gesteckt/eingebaut werden.

Deutschland:

Einhaltung des Gesetzes über die elektromagnetische Verträglichkeit von Betriebsmitteln

Dieses Produkt entspricht dem „Gesetz über die elektromagnetische Verträglichkeit von Betriebsmitteln“ EMVG (früher „Gesetz über die elektromagnetische Verträglichkeit von Geräten“). Dies ist die Umsetzung der EU-Richtlinie 2014/30/EU (früher 2004/108/EC) in der Bundesrepublik Deutschland.

Zulassungsbescheinigung laut dem Deutschen Gesetz über die elektromagnetische Verträglichkeit von Betriebsmitteln, EMVG vom 20. Juli 2007 (früher Gesetz über die elektromagnetische Verträglichkeit von Geräten), bzw. der EMV EU Richtlinie 2014/30/EU (früher 2004/108/EC), für Geräte der Klasse A.

Dieses Gerät ist berechtigt, in Übereinstimmung mit dem Deutschen EMVG das EG-Konformitätszeichen - CE - zu führen. Verantwortlich für die Konformitätserklärung nach Paragraph 5 des EMVG ist die Lenovo (Deutschland) GmbH, Meitnerstr. 9, D-70563 Stuttgart.

Informationen in Hinsicht EMVG Paragraph 4 Abs. (1) 4:

Das Gerät erfüllt die Schutzanforderungen nach EN 55024 und EN 55022 Klasse A.

Nach der EN 55022: „Dies ist eine Einrichtung der Klasse A. Diese Einrichtung kann im Wohnbereich Funkstörungen verursachen; in diesem Fall kann vom Betreiber verlangt werden, angemessene Maßnahmen durchzuführen und dafür aufzukommen.“

Nach dem EMVG: „Geräte dürfen an Orten, für die sie nicht ausreichend entstört sind, nur mit besonderer Genehmigung des Bundesministers für Post und Telekommunikation oder des Bundesamtes für Post und Telekommunikation betrieben werden. Die Genehmigung wird erteilt, wenn keine elektromagnetischen Störungen zu erwarten sind.“ (Auszug aus dem EMVG, Paragraph 3, Abs. 4). Dieses Genehmigungsverfahren ist nach Paragraph 9 EMVG in Verbindung mit der entsprechenden Kostenverordnung (Amtsblatt 14/93) kostenpflichtig.

Anmerkung: Um die Einhaltung des EMVG sicherzustellen sind die Geräte, wie in den Handbüchern angegeben, zu installieren und zu betreiben.

VCCI Class A Statement

この装置は、クラス A 情報技術装置です。この装置を家庭環境で使用すると電波妨害を引き起こすことがあります。この場合には使用者が適切な対策を講ずるよう要求されることがあります。 VCCI-A

This is a Class A product based on the standard of the Voluntary Control Council for Interference (VCCI). If this equipment is used in a domestic environment, radio interference may occur, in which case the user may be required to take corrective actions.

Japan Electronics and Information Technology Industries Association (JEITA) Statement

高調波ガイドライン適合品

Japanese Electronics and Information Technology Industries Association (JEITA)
Confirmed Harmonics Guideline (products less than or equal to 20 A per phase).

高調波ガイドライン準用品

Japan Electronics and Information Technology Industries Association (JEITA)
Confirmed Harmonics Guidelines with Modifications (products greater than 20 A per phase).

Korea Communications Commission (KCC) Statement

이 기기는 업무용(A급)으로 전자파적합기기로
서 판매자 또는 사용자는 이 점을 주의하시기
바라며, 가정외의 지역에서 사용하는 것을 목
적으로 합니다.

This is electromagnetic wave compatibility equipment for business (Type A).
Sellers and users need to pay attention to it. This is for any areas other than home.

Russia Electromagnetic Interference (EMI) Class A Statement

ВНИМАНИЕ! Настоящее изделие относится к классу А.
В жилых помещениях оно может создавать радиопомехи, для
снижения которых необходимы дополнительные меры

People's Republic of China Class A Electronic Emission Statement

中华人民共和国“A类”警告声明

声明

此为A级产品，在生活环境中，该产品可能会造成无线电干扰。在这种情况下，
可能需要用户对其干扰采取切实可行的措施。

Taiwan BSMI RoHS Declaration

設備名稱：交換器，型號（型式）：EN4093R Equipment Name Type Designation (Type)						
單元 Unit	限用物質及其化學符號 Restricted Substances and Their Chemical Symbols					
	鉛 Lead (Pb)	汞 Mercury (Hg)	鎘 Cadmium (Cd)	六價鉻 Hexavalent Chromium (Cr ⁶⁺)	多溴聯苯 Polybrominated Biphenyls (PBB)	多溴二苯醚 Polybrominated Diphenyl Ethers (PBDE)
外殼	○	○	○	○	○	○
印刷電路板	-	○	○	○	○	○
機械組零件	-	○	○	○	○	○
線材	-	○	○	○	○	○

Notes:

- 備考 1. “超出 0.1 wt %” 及 “超出 0.01 wt %” 係指限用物質之百分比含量超出百分比含量基準值。
“Exceeding 0.1 wt %” and “exceeding 0.01 wt %” indicate that the percentage content of the restricted substance exceeds the reference percentage value of presence condition.
- 備考 2. “○” 係指該項限用物質之百分比含量未超出百分比含量基準值。
“○” indicates that the percentage content of the restricted substance does not exceed the percentage of reference value of presence.
- 備考 3. “-” 係指該項限用物質為排除項目。
“-” indicates that the restricted substance corresponds to the exemption.

Taiwan Class A Compliance Statement

警告使用者：
此為甲類資訊技術設備，於居住環境中使用時，可能會造成射頻擾動，在此種情況下，使用者會被要求採取某些適當的對策。