

IBM Flex System Fabric SI4093 System Interconnect Module



# Application Guide

for Networking OS 7.7

Second Edition

**Note:** Before using this information and the product it supports, read the general information in the *Safety information and Environmental Notices and User Guide* documents on the IBM *Documentation CD* and the *Warranty Information* document that comes with the product.

**Second Edition (December 2013), Part Number 00CG189**

**© Copyright IBM Corporation 2013**

US Government Users Restricted Rights – Use, duplication or disclosure restricted by GSA ADP Schedule Contract with IBM Corp.

---

# Contents

<b>Preface</b> . . . . .	<b>.9</b>
Who Should Use This Guide . . . . .	.9
What You'll Find in This Guide . . . . .	.9
Additional References. . . . .	10
Typographic Conventions . . . . .	11
How to Get Help . . . . .	12
<b>Chapter 1. Introduction</b> . . . . .	<b>13</b>
Feature Summary . . . . .	13
Recommended System Deployments . . . . .	15
Basic Single-SPAR Topology . . . . .	15
VLAG Topology Modification . . . . .	16
Multi-SPAR Topology . . . . .	17
Recommended Workflow . . . . .	18
<b>Chapter 2. Administrative Access</b> . . . . .	<b>19</b>
Administration Interfaces . . . . .	19
Establishing a Connection . . . . .	20
Using the Chassis Management Module . . . . .	20
Factory-Default vs. CMM-Assigned IP Addresses. . . . .	20
Using Telnet . . . . .	21
Using Secure Shell . . . . .	21
Using Simple Network Management Protocol . . . . .	22
BOOTP/DHCP Client IP Address Services. . . . .	23
Host Name Configuration. . . . .	23
SYSLOG Server . . . . .	24
System Login Levels . . . . .	24
Secure FTP. . . . .	25
<b>Chapter 3. Initial Setup.</b> . . . . .	<b>27</b>
Information Needed for Setup. . . . .	27
Default Setup Options. . . . .	27
Stopping and Restarting Setup Manually . . . . .	28
Setup Part 1: Basic System Configuration . . . . .	28
Setup Part 2: Port Configuration. . . . .	29
Setup Part 3: IP Configuration . . . . .	30
IP Interfaces . . . . .	30
Default Gateways. . . . .	33
Setup Part 4: Final Steps . . . . .	33
Optional Setup for Telnet Support . . . . .	34
<b>Chapter 4. Administrative Security.</b> . . . . .	<b>35</b>
Changing the System Passwords . . . . .	35
Secure Shell and Secure Copy . . . . .	36
Configuring SSH/SCP . . . . .	37
Configuring the SCP Administrator Password . . . . .	37
Using SSH and SCP Client Commands . . . . .	38
SSH and SCP Encryption of Management Messages. . . . .	40
Generating the RSA Host Key for SSH Access . . . . .	40

SSH/SCP Integration with RADIUS Authentication . . . . .	40
SSH/SCP Integration with TACACS+ Authentication . . . . .	40
End User Access Control . . . . .	41
Considerations for Configuring End User Accounts . . . . .	41
Strong Passwords . . . . .	41
User Access Control Menu . . . . .	42
Listing Current Users . . . . .	43
Logging In to an End User Account. . . . .	43
Protected Mode . . . . .	43
<b>Chapter 5. Authentication &amp; Authorization Protocols . . . . .</b>	<b>45</b>
RADIUS Authentication and Authorization. . . . .	45
How RADIUS Authentication Works . . . . .	45
Configuring RADIUS on the SI4093 . . . . .	46
RADIUS Authentication Features in IBM Networking OS . . . . .	46
User Accounts . . . . .	47
RADIUS Attributes for IBM Networking OS User Privileges . . . . .	48
RADIUS Backdoor . . . . .	48
TACACS+ Authentication . . . . .	49
How TACACS+ Authentication Works. . . . .	49
TACACS+ Authentication Features in IBM Networking OS . . . . .	50
Authorization. . . . .	50
Backdoor . . . . .	51
Accounting . . . . .	51
Command Authorization and Logging. . . . .	51
Configuring TACACS+ Authentication on the SI4093. . . . .	52
LDAP Authentication and Authorization. . . . .	53
LDAP Backdoor . . . . .	53
Configuring the LDAP Server . . . . .	53
Configuring LDAP Authentication on the SI4093 . . . . .	54
<b>Chapter 6. Access Control Lists. . . . .</b>	<b>55</b>
Summary of Packet Classifiers . . . . .	56
Summary of ACL Actions . . . . .	58
Assigning Individual ACLs to a Port . . . . .	58
ACL Order of Precedence . . . . .	58
ACL Groups . . . . .	59
Assigning ACL Groups to a Port . . . . .	60
ACL Metering and Re-Marking . . . . .	60
ACL Port Mirroring . . . . .	61
Viewing ACL Statistics . . . . .	61
ACL Configuration Examples. . . . .	61
<b>Chapter 7. Updating the System Software . . . . .</b>	<b>63</b>
Determining the Current Software Version . . . . .	63
Getting the Latest SI4093 Software . . . . .	63
Loading New Software to Your SI4093 . . . . .	64
Recovering from a Failed Upgrade . . . . .	66
<b>Chapter 8. System License Keys . . . . .</b>	<b>69</b>
Obtaining Activation Keys . . . . .	70
Installing Activation Keys . . . . .	70
Transferring Activation Keys . . . . .	71

<b>Chapter 9. Switch Partition</b> . . . . .	<b>73</b>
SPAR Overview . . . . .	73
SPAR Ports Membership . . . . .	74
Default SPAR Ports . . . . .	74
Configuring SPAR Ports . . . . .	75
SPAR Modes . . . . .	77
Transparent SPARs . . . . .	77
VLAN-Aware SPARs . . . . .	78
Configuring VLAN-Aware Mode . . . . .	78
Disabling FDB Learning on Uplinks . . . . .	79
SPAR Default VLANs . . . . .	80
SPAR Restrictions . . . . .	80
Example Configurations . . . . .	81
Quick-Deployment SPAR Example . . . . .	81
Transparent SPAR Example . . . . .	82
VLAN-Aware SPAR Example . . . . .	83
<b>Chapter 10. QSFP+ Ports</b> . . . . .	<b>85</b>
<b>Chapter 11. Ports and Trunking</b> . . . . .	<b>87</b>
Trunking Overview . . . . .	87
Default Trunks . . . . .	88
Static Trunks . . . . .	89
Before Configuring Static Trunks . . . . .	89
Static Trunk Group Configuration Rules . . . . .	89
Configuring a Static Port Trunk . . . . .	90
Configurable Trunk Hash Algorithm . . . . .	92
Link Aggregation Control Protocol . . . . .	93
LACP Overview . . . . .	93
Configuring LACP . . . . .	95
<b>Chapter 12. Quality of Service</b> . . . . .	<b>97</b>
QoS Overview . . . . .	97
Using ACL Filters . . . . .	99
Summary of ACL Actions . . . . .	99
ACL Metering and Re-Marking . . . . .	99
Metering . . . . .	100
Re-Marking . . . . .	100
Using 802.1p Priorities to Provide QoS . . . . .	101
Queuing and Scheduling . . . . .	102
<b>Chapter 13. Basic IP Addresses</b> . . . . .	<b>103</b>
<b>Chapter 14. Internet Protocol Version 6</b> . . . . .	<b>105</b>
IPv6 Limitations . . . . .	105
IPv6 Address Format . . . . .	106
IPv6 Address Types . . . . .	107
IPv6 Address Autoconfiguration . . . . .	108
IPv6 Management Interfaces . . . . .	108
Neighbor Discovery . . . . .	109
Supported Applications . . . . .	110
Configuration Guidelines . . . . .	112
IPv6 Configuration Examples . . . . .	112

<b>Chapter 15. Fibre Channel over Ethernet . . . . .</b>	<b>115</b>
FCoE Overview . . . . .	115
The FCoE Topology . . . . .	115
FCoE Security . . . . .	116
FIP-Aware FCoE . . . . .	116
Transparent FCoE . . . . .	116
FCoE Requirements . . . . .	117
Port Trunking . . . . .	117
Converged Enhanced Ethernet . . . . .	118
Turning CEE On or Off . . . . .	118
Effects on Link Layer Discovery Protocol . . . . .	118
Effects on 802.1p Quality of Service . . . . .	119
Effects on Flow Control . . . . .	120
FCoE Initialization Protocol Snooping . . . . .	121
Global FIP Snooping Settings . . . . .	121
FIP Snooping for Specific Ports . . . . .	122
Port FCF and ENode Detection . . . . .	122
FCoE Connection Timeout . . . . .	122
FCoE ACL Rules . . . . .	123
FCoE VLANs . . . . .	123
Viewing FIP Snooping Information . . . . .	124
FIP Snooping Configuration . . . . .	125
Priority-Based Flow Control . . . . .	126
Global vs. Port-by-Port PFC Configuration . . . . .	127
PFC Configuration Example . . . . .	128
Enhanced Transmission Selection. . . . .	130
802.1p Priority Values . . . . .	130
Priority Groups . . . . .	131
PGID . . . . .	131
Assigning Priority Values to a Priority Group . . . . .	132
Deleting a Priority Group . . . . .	132
Allocating Bandwidth. . . . .	133
Configuring ETS . . . . .	134
Data Center Bridging Capability Exchange . . . . .	136
DCBX Settings . . . . .	136
Configuring DCBX . . . . .	138
FCoE Example Configuration . . . . .	140
<b>Chapter 16. Link Layer Discovery Protocol . . . . .</b>	<b>145</b>
LLDP Overview . . . . .	145
Enabling or Disabling LLDP . . . . .	146
Global LLDP Setting . . . . .	146
Transmit and Receive Control. . . . .	146
LLDP Transmit Features . . . . .	147
Scheduled Interval . . . . .	147
Minimum Interval. . . . .	147
Time-to-Live for Transmitted Information . . . . .	148
Trap Notifications . . . . .	148
Changing the LLDP Transmit State. . . . .	149
Types of Information Transmitted . . . . .	149

LLDP Receive Features . . . . .	.150
Types of Information Received. . . . .	.150
Viewing Remote Device Information . . . . .	.151
Time-to-Live for Received Information . . . . .	.152
LLDP Example Configuration . . . . .	.152
<b>Chapter 17. Simple Network Management Protocol . . . . .</b>	<b>.153</b>
SNMP Version 1 . . . . .	.153
SNMP Version 3 . . . . .	.153
Configuring SNMP Trap Hosts . . . . .	.155
SNMP MIBs . . . . .	.158
Switch Images and Configuration Files . . . . .	.160
Loading a New Switch Image . . . . .	.161
Loading a Saved Switch Configuration . . . . .	.161
Saving the Switch Configuration . . . . .	.162
Saving a Switch Dump . . . . .	.162
<b>Chapter 18. Service Location Protocol . . . . .</b>	<b>.163</b>
Active DA Discovery . . . . .	.164
SLP Configuration . . . . .	.164
<b>Chapter 19. Layer 2 Failover . . . . .</b>	<b>.165</b>
Setting the Failover Limit . . . . .	.165
Manually Monitoring Port Links . . . . .	.165
Configuration Guidelines . . . . .	.166
Configuring Layer 2 Failover . . . . .	.166
<b>Appendix A. Getting help and technical assistance . . . . .</b>	<b>.167</b>
Before you call . . . . .	.167
Using the documentation . . . . .	.167
Getting help and information on the World Wide Web . . . . .	.168
Software service and support . . . . .	.168
Hardware service and support . . . . .	.168
IBM Taiwan product service . . . . .	.169
<b>Appendix B. Notices. . . . .</b>	<b>.171</b>
Trademarks. . . . .	.172
Important Notes . . . . .	.173
Particulate contamination . . . . .	.174
Documentation format . . . . .	.175
Electronic emission notices . . . . .	.176
<b>Index . . . . .</b>	<b>.181</b>





---

## Preface

The *IBM Networking OS Application Guide* describes how to configure and use the IBM Networking OS 7.7 software on the IBM Flex System Fabric SI4093 System Interconnect Module (referred to as SI4093 throughout this document).

For documentation about installing the device physically, see the *Installation Guide* for your SI4093.

---

## Who Should Use This Guide

This guide is intended for network installers and system administrators engaged in configuring and maintaining a network. The administrator should be familiar with Ethernet concepts, IP addressing and SNMP configuration parameters.

---

## What You'll Find in This Guide

This guide will help you plan, implement, and administer IBM Networking OS software. Where possible, each section provides feature overviews, usage examples, and configuration instructions. The following material is included:

- [Chapter 1, "Introduction,"](#) describes basic concepts for SI4093 usage.
- [Chapter 2, "Administrative Access,"](#) describes how to access the SI4093 in order to configure the device and view its information. This chapter discusses a variety of manual administration interfaces, including local management via the Console port, and remote administration via Telnet or SNMP.
- [Chapter 3, "Initial Setup,"](#) describes how to use the built-in Setup utility to perform first-time configuration.
- [Chapter 4, "Administrative Security,"](#) describes methods for changing the default system passwords, using Secure Shell and Secure Copy for administration connections, configuring end-user access control, and placing the SI4093 in protected mode.
- [Chapter 5, "Authentication & Authorization Protocols,"](#) describes different methods of secure administration for remote administrators. This includes Remote Authentication Dial-in User Service (RADIUS), as well as TACACS+ and LDAP.
- [Chapter 6, "Access Control Lists,"](#) describes how to use filters to permit or deny specific types of traffic based on a variety of source, destination, and packet attributes.
- [Chapter 7, "Updating the System Software,"](#) describes how to update the software that controls SI4093 operation.
- [Chapter 8, "System License Keys,"](#) describes how to obtain and install licenses for activating optional expansion features on the SI4093.
- [Chapter 9, "Switch Partition,"](#) describes the creation of multiple Switch Partitions (SPARs) within the SI4093 to form and enforce distinct, virtual contexts for multitenancy.
- [Chapter 10, "QSFP+ Ports,"](#) describes how to set the operational mode of the QSFP+ ports on the SI4093.
- [Chapter 11, "Ports and Trunking,"](#) describes how to group multiple physical ports together to aggregate their bandwidth between large-scale devices.
- [Chapter 12, "Quality of Service,"](#) discusses Quality of Service (QoS) features, including IP filtering using Access Control Lists (ACLs), Differentiated Services, and IEEE 802.1p priority values.

- [Chapter 13, “Basic IP Addresses,”](#) describes how to configure the BOOTP and DHCP Relay.
- [Chapter 14, “Internet Protocol Version 6,”](#) describes how to configure the SI4093 for IPv6 host management.
- [Chapter 15, “Fibre Channel over Ethernet,”](#) discusses using various Converged Enhanced Ethernet (CEE) features such as Priority-based Flow Control (PFC), Enhanced Transmission Selection (ETS), and FIP Snooping for solutions such as Fibre Channel over Ethernet (FCoE).
- [Chapter 16, “Link Layer Discovery Protocol,”](#) describes how Link Layer Discovery Protocol helps neighboring network devices learn about each others’ ports and capabilities.
- [Chapter 17, “Simple Network Management Protocol,”](#) describes how to configure the SI4093 for management through an SNMP client.
- [Chapter 18, “Service Location Protocol,”](#) describes the Service Location Protocol (SLP) that allows the SI4093 to provide dynamic directory services.
- [Chapter 19, “Layer 2 Failover,”](#) describes how the SI4093 supports high-availability network topologies using Layer 2 Failover.
- [Appendix A, “Getting help and technical assistance,”](#) describes how to get help.
- [Appendix B, “Notices,”](#) provides trademark and other compliance information.

---

## Additional References

Additional information about installing and configuring the SI4093 is available in the following guides:

- *IBM Flex System Fabric SI4093 System Interconnect Module User’s Guide (Installation)*
- *IBM Flex System Fabric SI4093 System Interconnect Module CLI Command Reference for IBM Networking OS 7.7*

## Typographic Conventions

The following table describes the typographic styles used in this book.

Table 1. *Typographic Conventions*

Typeface or Symbol	Meaning	Example
ABC123	This type is used for names of commands, files, and directories used within the text.  It also depicts on-screen computer output and prompts.	View the <code>readme.txt</code> file.  <code>host#</code>
ABC123	This bold type appears in command examples. It shows text that must be typed in exactly as shown.	<code>host# sys</code>
<ABC123>	This italicized type appears in command examples as a parameter placeholder. Replace the indicated text with the appropriate real name or value when using the command. Do not type the brackets.  This also shows book titles, special terms, or words to be emphasized.	To establish a Telnet session, enter: <code>host# telnet &lt;IP address&gt;</code>  Read your <i>User's Guide</i> thoroughly.
[ ]	Command items shown inside brackets are optional and can be used or excluded as the situation demands. Do not type the brackets.	<code>host# ls [-a]</code>
	The vertical bar (   ) is used in command examples to separate choices where multiple options exist. Select only one of the listed options. Do not type the vertical bar.	<code>host# set left right</code>
AaBbCc123	This block type depicts menus, buttons, and other controls that appear in Web browsers and other graphical interfaces.	Click the <b>Save</b> button.

---

## How to Get Help

If you need help, service, or technical assistance, visit our website at the following address:

You also can visit our web site at the following address:

<http://www.ibm.com/support>

Click the **Support** tab.

The warranty card received with your product provides details for contacting a customer support representative. If you are unable to locate this information, please contact your reseller. Before you call, prepare the following information:

- Serial number of the SI4093
- Software release version number
- Brief description of the problem and the steps you have already taken
- Technical support dump information (`show tech-support`)

---

# Chapter 1. Introduction

The IBM Flex System Fabric SI4093 System Interconnect Module (referred to as SI4093 throughout this document) provides simplified interconnect options for the IBM Flex System and IBM PureFlex System environments. The SI4093 facilitates low-latency, media-speed server-to-server traffic within the chassis, based on established Ethernet Layer 2 bridging protocols.

---

## Feature Summary

### Easy Connectivity

The SI4093 provides a low-touch, easy-to-use connection between server elements within the chassis, and the upstream infrastructure. The simplified interface eliminates the complexity normally associated with embedded Layer 2/Layer 3 switches.

With its basic license, the SI4093 provides 14 internal 1/10 Gbps Ethernet ports that connect to servers within the chassis, and 10 external 1/10 Gbps SFP+ Ethernet ports for uplink to the network. By default, all 24 basic-license ports are grouped into one Switch Partition (see [“Switch Partitions” on page 14](#)).

After initial start-up, the basic license uplinks are pre-configured by default to form a single, loop-free IEEE 802.1 Link Aggregation Group (LAG) that allows for plug-and-play operation. In this state, you can attach as many of the available uplink ports as required to meet application bandwidth requirements to an upstream device configured with appropriate LACP properties (see [“Link Aggregation Control Protocol” on page 93](#)).

### Flexible Expansion

With optional license keys, additional ports are available for expansion. Two upgrades are available:

- Upgrade License 1  
Adds 14 internal 1/10 Gbps Ethernet ports. This license also adds a pair of external QSFP+ ports, each of which can operate as four 10 Gbps Ethernet ports (by default) or a 40 Gbps Ethernet port if desired.
- Upgrade License 2 (requires upgrade license 1)  
Adds 14 internal 1/10 Gbps Ethernet ports, and 4 external 1/10 Gbps SFP+ Ethernet ports.

For details on upgrade port availability, see [“System License Keys” on page 69](#).

### Easy Management

In addition to the built-in command-line interface, the IBM System Network Switch Center (SNSC) tool can be used for centralized management for multiple SI4093 devices:

- Examining and modifying the configuration of the SI4093.
- Archiving configurations for faster deployment to new chassis or to replacement SI4093 devices.

- Continuous monitoring of SI4093 operation, with alerts of events that may impact connectivity.
- Retrieving traffic statistics and other operational information.

For management details, see [“Administrative Access” on page 19](#), as well as the *IBM Flex System Fabric SI4093 System Interconnect Module Command Reference for IBM Networking OS 7.7*.

## Switch Partitions

The SI4093 uses Switch Partition (SPAR) technology. This allows you to assign available ports to different traffic zones (partitions), as might be required to enforce multi-tenancy traffic segregation and security applications.

Traffic in each SPAR remains entirely segregated from all the others for the entire duration of its transit through the SI4093.

By default, the SI4093 ports are each assigned to a default SPAR based on the active system license keys (see [page 69](#)).

For more information, see [“Switch Partition” on page 73](#).

## Loop-Free Operation Without STP

Unlike traditional switches, the SI4093 prevents data loops among connected links without relying on slow, complicated IEEE 802.1 Spanning-Tree Protocols.

## Server Failover

To assist in providing seamless failover in the event of connectivity disruptions outside the chassis, Layer 2 Failover is enabled by default. If the number of operational links between the SI4093 and the upstream device falls below a configurable threshold, the SI4093 will close all internal server ports associated with the affected SPARs, signalling the NICs on the affected servers to initiate failover to an alternate SI4093.

By default, at least one uplink connection must be operational in order for the internal server ports to remain operational.

For more information, see [“Layer 2 Failover” on page 165](#).

## Converged Data and Storage Applications

The SI4093 provides convergence for traditional Ethernet traffic and Fibre Channel over Ethernet (FCoE) storage session traffic on all internal and external links, thus reducing the need for separate data and Storage Area Network (SAN) infrastructures.

For more information, see [“Fibre Channel over Ethernet” on page 115](#).

---

## Recommended System Deployments

### Basic Single-SPAR Topology

One recommended SI4093 deployment is shown in [Figure 1](#):

Figure 1. Basic SI4093 Topology

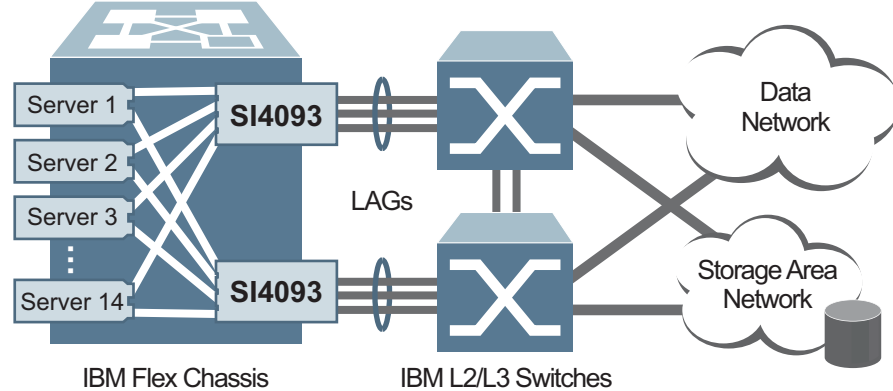

In this deployment, a pair of SI4093 devices is used in each IBM Flex chassis, installed in I/O Bays 1 and 2, with each assigned a unique IP address and default gateway via the Flex Chassis Management Module (CMM).

This provides redundant data paths through the chassis while also providing additional internal and external bandwidth during normal operation. Additional SI4093 devices can be installed in I/O Bays 3 and 4 when additional I/O bandwidth or server NICs are needed. In addition, each SI4093 device is attached to separate external switches to achieve the desired redundancy, protecting against a single point of failure.

Each server has a dual-port 10Gbps Ethernet interface, with each interface independently connected to one of the two SI4093 devices. For each server, optional 4-port and 8-port mezzanine cards are available for applications that require greater than 20 Gbps of bandwidth per server, or additional redundancy.

It is recommended that NIC teaming (or bonding) be configured on each server. NIC teaming allows redundant NICs on each server to create an active path and a backup path to the pair of SI4093 devices. Loss of one SI4093 device (such as when it is removed from the chassis), or removal or loss of all uplinks due to failure of an upstream device, will force the corresponding internal server links to close, thus signalling the NIC teaming capability in the server to use the backup path.

In the most basic topology available with the basic license, 14 internal ports and 10 external ports are grouped into a single default SPAR.

The multiple external uplinks on the SI4093 are grouped together to form a single, loop-free channel (also known as a trunk or Link Aggregation Group) to the upstream switch. Two uplinks per SI4093 are the minimum recommended for redundancy.

During SI4093 operation, at least one active uplink port is required for each SPAR. Otherwise, the internal ports for the SPAR will remain inactive. This avoids situations where an internal server path is active but has no corresponding path to the external domains.

If desired, converged network adapters on each server allow Fibre Channel storage traffic to share the internal and external links with the normal Ethernet traffic. The corresponding FCoE support must be configured in the external upstream device, such as the IBM System Networking RackSwitch G8264CS, to redirect the Fibre Channel traffic streams to the corresponding Storage Area Network (SAN).

As with NIC teaming, FCoE multi-path protocols on the server will redirect FCoE session traffic to an alternate path when the primary path is disrupted.

## VLAG Topology Modification

An alternate single-SPAR topology is shown in [Figure 2](#):

Figure 2. SI4093 VLAG Topology

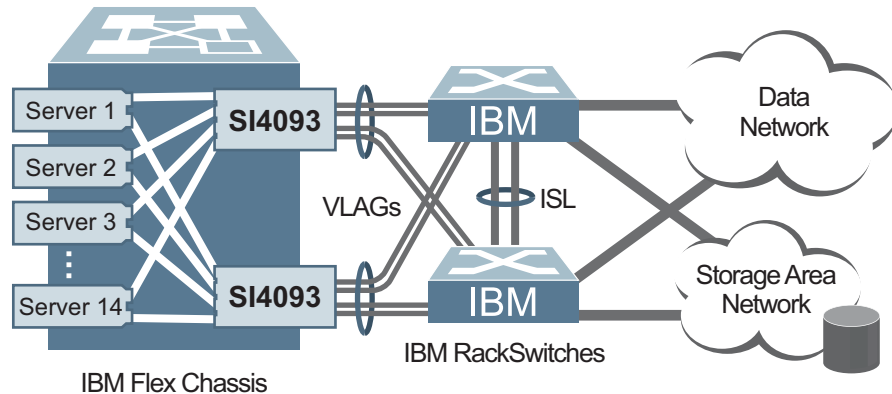

This deployment takes advantage of the Virtual Link Aggregation Group (VLAG) capability available when the SI4093 is connected to the IBM System Networking RackSwitch G8264 or RackSwitch G8264CS. This allows the SI4093 uplink channel to be physically distributed across a pair of upstream switches. The RackSwitch devices are peered using an inter-switch link (ISL) so that they act in concert, appearing as if a single switch to each SI4093 device.

As with the basic topology, the VLAG topology utilizes NIC teaming and FCoE multi-path redundancy options configured at the server. These options provide seamless failover in the event of connectivity disruptions outside the chassis.

SAN domains, when present, are managed and controlled via the external converged network and storage devices. For example, using an IBM System Networking RackSwitch G8264CS as the uplink switch can provide converged Ethernet and 8-Gbps Fibre Channel storage access, with the capability to divert the storage session traffic from each chassis to the targeted storage elements.

The SI4093 can also be used to interface to Cisco Nexus 50XX converged network switches.



## Multi-SPAR Topology

When multiple SPARs are required, as for multi-tenancy applications, the recommended deployment is as shown in [Figure 3](#):

Figure 3. SI4093 Multi-SPAR Topology

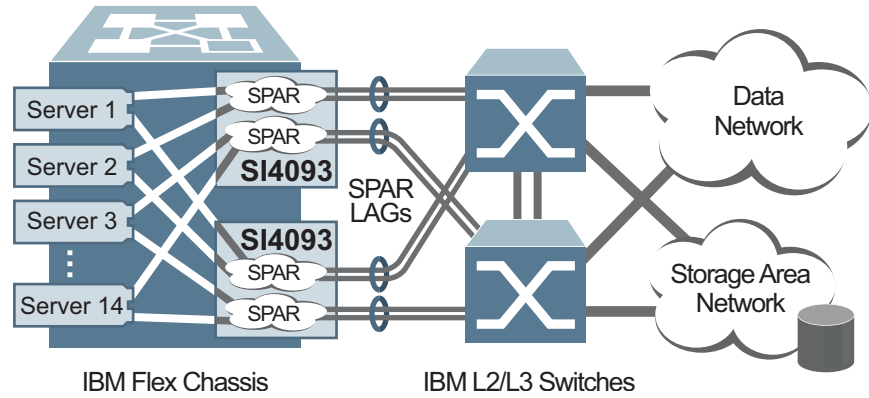

This topology shows two SPARs configured on each SI4093. The SI4093 supports up to eight individual SPARs. Each SPAR has its own unique set of internal and external ports.

In other respects, the topology is similar to the single-SPAR topology, and can even be used with VLAGs topologies.

Because each SPAR is connected to a different upstream network, the traffic in each SPAR remains separate from the other SPARs, even if their tenants internally make use of the same VLAN IDs.

It is also possible to connect more than one SPAR from a given SI4093 to the same upstream network (instead of connecting them to different upstream devices). However, this requires additional configuration to prevent sessions from unintentionally migrating to different ports (being interpreted as station changes) when use of the same VLAN is detected ports in different SPARs (see [“Disabling FDB Learning on Uplinks”](#) on page 79).

---

## Recommended Workflow

The SI4093 is ready to provide limited function right out of the box. However, to utilize the device most effectively, some degree of custom configuration is recommended. The most common steps for SI4093 deployment are as follows:

- Access the SI4093 command line (see [Chapter 2](#)).
- Use the Setup wizard to initialize the system (see [Chapter 3](#)”).
- Change default passwords (see [Chapter 4](#)).
- Update firmware to the most current version (see [Chapter 7](#)).
- Install optional upgrade keys to activate additional ports (see [Chapter 8](#)).
- Configure SPARs (see [Chapter 9](#)).
- Configure optional FCoE if desired (see [Chapter 15](#)).
- Configure other optional features.
- Back-up your configuration.
- Monitor and adjust operations as necessary.

**Note:** The steps listed are for a generic deployment. Depending on your specific requirements, your actual workflow may differ.

---

## Chapter 2. Administrative Access

The SI4093 is ready to perform basic functions right out of the box. Some of the more advanced features, however, require some administrative set-up before they can be used effectively.

The SI4093 provides a variety of options for accessing the device to perform configuration, and to view operational information and statistics.

This chapter discusses the various methods that can be used to administer the SI4093.

---

### Administration Interfaces

The SI4093 software provides a variety of user-interfaces for administration:

- The Flex System Chassis Management Module (CMM). The Flex System chassis includes a CMM as the central element for overall chassis management and control. Using the tools available through the CMM, the administrator can configure many of the SI4093 features and can also access other SI4093 administration interfaces.
- A built-in, text-based command-line interface is available for access via the Console port or an optional Telnet or SSH session.
- SNMP support for access through network management software such as IBM Director.

The specific interface chosen for an administrative session depends on user preferences, as well as the SI4093 configuration and the available client tools.

In all cases, administration requires that the SI4093 hardware is properly installed and turned on (see the *IBM Flex System Fabric SI4093 System Interconnect Module User's Guide*).

---

## Establishing a Connection

The factory default settings permit initial SI4093 administration through *only* the built-in Console port or CMM. All other forms of access require additional configuration before they can be used.

Remote access using the network requires the accessing terminal to have a valid, routable connection to the SI4093 interface. This requires that the SI4093 be configured with a client IP address. The address may be configured manually, or an IPv4 address can be provided automatically by the SI4093 using a service such as DHCP or BOOTP client (see [“BOOTP/DHCP Client IP Address Services” on page 23](#)), or an IPv6 address can be obtained using IPv6 stateless address configuration.

**Note:** Throughout this manual, *IP address* is used in places where either an IPv4 or IPv6 address is allowed. IPv4 addresses are entered in dotted-decimal notation (for example, 10.10.10.1), while IPv6 addresses are entered in hexadecimal notation (for example, 2001:db8:85a3::8a2e:370:7334). In places where only one type of address is allowed, *IPv4 address* or *IPv6 address* is specified.

## Using the Chassis Management Module

The SI4093 is an integral subsystem within the overall IBM Flex System. The Flex System chassis includes a chassis management module (CMM) as the central element for overall chassis management and control.

The SI4093 uses port 66 (MGT1) to communicate with the chassis management module(s). Even when the SI4093 is in a factory default configuration, you can use the 1Gb Ethernet port on each CMM to configure and manage the SI4093.

For more information about using the chassis management module, see the SI4093 installation guide.

## Factory-Default vs. CMM-Assigned IP Addresses

Each SI4093 must be assigned its own Internet Protocol version 4 (IPv4) address, which is used for communication with an SNMP network manager or other transmission control protocol/Internet Protocol (TCP/IP) applications (for example, BOOTP or TFTP). The factory-default IPv4 address is 10.90.90.*x*, where *x* is based on the number of the bay into which the SI4093 is installed. For additional information, see the *Installation Guide*. The chassis management module assigns an IPv4 address of 192.168.70.1*xx*, where *xx* is also based on the number of the bay into which each SI4093 is installed, as shown in the following table:

Table 2. SI4093 IPv4 addresses, by chassis module bay numbers

Bay Number	Factory-Default IPv4 Address	IPv4 Address Assigned by CMM
Bay 1	10.90.90.91	192.168.70.120
Bay 2	10.90.90.92	192.168.70.121
Bay 3	10.90.90.93	192.168.70.122
Bay 4	10.90.90.94	192.168.70.123

**Note:** SI4093s installed in Bay 1 and Bay 2 connect to server NICs 1 and 2, respectively.

## Using Telnet

A Telnet connection offers the convenience of accessing the SI4093 from a workstation connected to the network. Telnet access provides the same options for user and administrator access as those available through the Console port.

By default, Telnet access is disabled. After initial setup of the SI4093 (see [Chapter 3, "Initial Setup"](#)), use the following commands (only available when using the Console port) to enable or disable Telnet access:

```
SI 4093> enable
SI 4093# configure terminal
SI 4093(config)# [no] access telnet enable
```

Once the SI4093 is configured with an IP address and gateway, you can use Telnet to access device administration from any workstation connected to the management network.

To establish a Telnet connection with the SI4093, run the Telnet program on client your workstation and issue the following Telnet command:

```
telnet <SI4093 IPv4 or IPv6 address>
```

You will then be prompted to enter a password as explained ["System Login Levels" on page 24](#).

## Using Secure Shell

Although a remote administrator can manage the configuration of a SI4093 via Telnet, this method does not provide a secure connection. The Secure Shell (SSH) protocol enables you to securely log in over a network to execute commands remotely. As a secure alternative to using Telnet to manage SI4093 configuration, SSH ensures that the management session is encrypted.

The SI4093 supports only one session of key/cipher generation at a time. Thus, a SSH/SCP client will not be able to login if the SI4093 is performing key generation at that time. Similarly, the system will fail key generation if an SSH/SCP client is logging in at that time.

The SI4093 supports the following encryption and authentication methods for SSH and SCP:

- Server Host Authentication: 1024-bit RSA host key
- Key Exchange: diffie-hellman-group1-sha1, diffie-hellman-group14-sha1
- Encryption: 3des-cbc, aes128-cbc, aes128-ctr, arcfour, arcfour128, arcfour256, blowfish-cbc, rijndael128-cbc
- MAC: hmac-md5, hmac-md5-96, hmac-sha1, hmac-sha1-96
- User Authentication: Local password authentication, LDAP, RADIUS, TACACS+

## Using SSH to Access the SI4093

By default, the SSH feature is enabled. For information about enabling and using SSH for SI4093 access, see [“Secure Shell and Secure Copy” on page 36](#).

Once the IP parameters are configured, you can access the command line interface using an SSH connection.

To establish an SSH connection with the SI4093, run the SSH program on your client workstation by issuing the SSH command, followed by the SI4093 IPv4 or IPv6 address:

```
ssh <SI4093 IP address>
```

You will then be prompted to enter a password as explained [“System Login Levels” on page 24](#).

## Using Simple Network Management Protocol

SI4093 software provides Simple Network Management Protocol (SNMP) version 1, version 2, and version 3 support for access through any network management software, such as IBM Director.

To access the SNMP agent on the SI4093, the read and write community strings on the SNMP manager should be configured to match those on the SI4093. The default read community string on the SI4093 is `public` and the default write community string is `private`.

The read and write community strings on the SI4093 can be changed using the following privileged configuration commands:

```
SI 4093(config)# snmp-server read-community <1-32 characters>  
  
-and-  
  
SI 4093(config)# snmp-server write-community <1-32 characters>
```

The SNMP manager should be able to reach any one of the IP interfaces on the SI4093.

For the SNMP manager to receive the SNMPv1 traps sent out by the SNMP agent on the SI4093, configure the trap host on the SI4093 with the following commands:

```
SI 4093(config)# snmp-server trap-src-if <trap source IP interface>  
SI 4093(config)# snmp-server host <IPv4 address> <trap host community string>
```

For more information on SNMP usage and configuration, see [“Simple Network Management Protocol” on page 153](#).

---

## BOOTP/DHCP Client IP Address Services

For remote SI4093 administration, the client terminal device must have a valid IP address on the same network as an interface on the SI4093. The IP address on the client device may be configured manually, or obtained automatically using IPv6 stateless address configuration, or an IPv4 address may be obtained automatically via BOOTP or DHCP relay as discussed below.

When the SI4093 receives a BOOTP/DHCP request from a client seeking an IPv4 address, the SI4093 acts as a proxy for the client. The request is forwarded as a UDP Unicast MAC layer message to the BOOTP/DHCP servers configured for the client's VLAN, or to the global BOOTP/DHCP servers if no domain-specific BOOTP/DHCP servers are configured for the client's VLAN. The servers respond to the SI4093 with a Unicast reply that contains the IPv4 default gateway and the IPv4 address for the client. The SI4093 then forwards this reply back to the client.

DHCP is described in RFC 2131. DHCP uses UDP as its transport protocol. The client sends messages to the server on port 67 and the server sends messages to the client on port 68.

BOOTP and DHCP relay are collectively configured using the BOOTP commands on the SI4093.

For more information, see [“Basic IP Addresses” on page 103](#).

## Host Name Configuration

The SI4093 supports DHCP host name configuration as described in RFC 2132, option 12. DHCP host name configuration is enabled by default.

Host name can be manually configured using the following command:

```
SI 4093(config)# hostname <name>
```

If the host name is manually configured, the SI4093 does not replace it with the host name received from the DHCP server.

After the host name is configured on the SI4093, if DHCP or DHCP host name configuration is disabled, the SI4093 retains the host name.

To help avoid misconfiguration during management of multiple similar devices, the SI4093 command prompt includes the host name.

Host name configuration can be enabled/disabled using the following command:

```
SI 4093(config)# [no] system dhcp hostname
```

## SYSLOG Server

During SI4093 startup, if the system fails to read its configuration file, a message can be recorded in the SYSLOG server.

The SI4093 supports requesting a SYSLOG server IP address from the DHCP server as described in RFC 2132, option 7. DHCP SYSLOG server request option is enabled by default.

If SYSLOG server address is manually configured, it will take priority over a DHCP-assigned SYSLOG server.

Up to two SYSLOG server addresses received from the DHCP server can be used. The SYSLOG server address can be obtained over a management port or a data port.

Use the `show logging` command to view the SYSLOG server address.

DHCP SYSLOG server address option can be enabled/disabled using the following command:

```
SI 4093(config)# [no] system dhcp syslog
```

---

## System Login Levels

To enable better system management and user accountability, three levels or *classes* of user access have been implemented on the SI4093. Privileges for each level of access increase as needed to perform various management tasks. Conceptually, access classes are defined as follows:

- User interaction with the SI4093 is completely passive—nothing can be changed on the system. Users may display information that has no security or privacy implications, such as device statistics and current operational state information.
- Operators can only effect temporary changes on the SI4093. These changes will be lost when the system is rebooted/reset. Operators have access to the system management features used for regular operations. Because any changes an operator makes are undone when the device is reset, operators cannot permanently impact operation.
- Administrators are the only ones that may make permanent changes to the SI4093 configuration—changes that are persistent across a reboot/reset of the device. Administrator access is used for configuring and troubleshooting the SI4093. Because administrators can also make temporary (operator-level) changes, they must be aware of the interactions between temporary and permanent changes.

Access to the SI4093 is controlled through the use of unique user names and passwords. Once you are connected to the SI4093 via Console port, remote Telnet, or SSH, you are prompted to enter a password. The default user names/password for each access level are listed in the following table.

**Note:** It is recommended that you change default SI4093 passwords after initial configuration and as regularly as required under your network security policies. For more information, see [“Changing the System Passwords” on page 35](#).



Table 3. User Access Levels - Default Settings

User Account	Password	Description and Tasks Performed	Default
user	user	The User has no direct responsibility for SI4093 management. He or she can view all status information and statistics, but cannot make any configuration changes.	Enabled
oper	oper	The Operator manages all functions of the SI4093. The Operator can reset all ports except the management ports.	Disabled
admin	admin	The superuser Administrator has complete access to all menus, information, and configuration commands on the SI4093, including the ability to change both the user and administrator passwords.	Enabled
USERID	PASSWORD (with a zero)	An alternate administrator account. This admin-level account occupies end-user ID 1 (see <a href="#">“End User Access Control” on page 41</a> ).	Enabled

**Note:** Access to user and oper accounts can be disabled by setting their password to an empty value. Administrator accounts cannot be disabled.

---

## Secure FTP

The SI4093 supports Secure FTP (SFTP). SFTP uses Secure Shell (SSH) to transfer files. SFTP encrypts both commands and data, and prevents passwords and sensitive information from being transmitted openly over the network. The following command is an example of SFTP support on the SI4093:

```
SI 4093# copy sftp {image1|image2|boot-image} [mgt-port|extm-port]
```

This command copies a software file from the SFTP server to the SI4093.



---

## Chapter 3. Initial Setup

To help with the initial process of configuring your SI4093, the built-in software includes a Setup utility. The Setup utility prompts you step-by-step to enter all the necessary information for basic configuration of the device.

The SI4093 will automatically prompt you whether or not to run the Setup utility when factory default settings are detected. Setup can also be activated manually from the Command Line Interface (CLI).

---

### Information Needed for Setup

Setup requests the following information:

- Basic system information such as date & time
- Optional configuration for internal port negotiation mode
- Optional configuration of IP parameters
  - IP address for each IP management interface
  - IP address for the default gateway

---

### Default Setup Options

The Setup prompt appears automatically whenever you login as the system administrator under the factory default settings.

1. Connect to the SI4093 via one of the methods described in [“Establishing a Connection” on page 20](#).

After connecting, the login prompt will appear as shown here.

```
Enter login username:
```

2. At the prompt, enter the administrator user name. If the system is set to factory defaults, type `USERID` and press <Enter>:

After connecting, the login prompt will appear as shown here.

```
Enter login username: USERID
```

3. When prompted, enter the administrator password. If the system is set to factory defaults, type `PASSWORD` (with a zero) and press <Enter>:

```
Enter login password: PASSWORD
```

**Note:** For security purposes, the text that you type for the password will not be displayed on the screen even though it is being processed.

4. If factory default settings are in place, the SI4093 will prompt whether or not you wish to run the Setup utility:

```
The switch is booted with factory default configuration.  
To ease the configuration of the switch, a "Set Up" facility which  
will prompt you with those configuration items that are essential  
to the operation of the switch is provided.
```

```
Would you like to run "Set Up" to configure the switch? [y/n]
```

5. Enter `y` to begin the initial configuration of the SI4093, or `n` to bypass the Setup utility.

**Note:** If you elect to bypass initial setup, you can manually restart the Setup utility at a later time (see [“Stopping and Restarting Setup Manually” on page 28](#)).

---

## Stopping and Restarting Setup Manually

### Stopping Setup

To abort the Setup utility while it is running, press `<Ctrl-C>` at any Setup question. When you abort Setup, the system will prompt:

```
Would you like to run from top again? [y/n]
```

Enter `n` to abort Setup, or `y` to restart the Setup program at the beginning.

### Restarting Setup

You can restart the Setup utility manually at any time by entering the following CLI commands:

```
SI 4093> enable
SI 4093# setup
```

The `enable` command initiates Privileged EXEC mode. The `setup` command can be executed in Privileged EXEC mode, and also in the Privileged EXEC configuration mode (at the `config` prompt).

---

## Setup Part 1: Basic System Configuration

When Setup is started, the system prompts:

```
"Set Up" will walk you through the configuration of
System Date and Time, Spanning Tree, Port Speed/Mode,
VLANs, and IP interfaces. [type Ctrl-C to abort "Set Up"]
```

Next, the Setup utility prompts you to input basic system information.

1. Enter the year of the current date at the prompt:

```
System Date:
Enter year [2013]:
```

Enter the four-digits that represent the year. To keep the current year, press `<Enter>`.

2. Enter the month of the current system date at the prompt:

```
Enter month [11]:
```

Enter the month as a number from 1 to 12. To keep the current month, press `<Enter>`.

3. Enter the day of the current date at the prompt:

```
Enter day [15]:
```

Enter the date as a number from 1 to 31. To keep the current day, press <Enter>. The system displays the date and time settings:

```
System clock set to 18:55:36 Fri Nov 15, 2013.
```

4. Enter the hour of the current system time at the prompt:

```
System Time:  
Enter hour in 24-hour format [18]:
```

Enter the hour as a number from 00 to 23. To keep the current hour, press <Enter>.

5. Enter the minute of the current time at the prompt:

```
Enter minutes [55]:
```

Enter the minute as a number from 00 to 59. To keep the current minute, press <Enter>.

6. Enter the seconds of the current time at the prompt:

```
Enter seconds [37]:
```

Enter the seconds as a number from 00 to 59. To keep the current second, press <Enter>. The system then displays the date and time settings:

```
System clock set to 18:55:37 Fri Nov 15, 2013.
```

---

## Setup Part 2: Port Configuration

**Note:** The sample screens that appear in this document might differ slightly from the screens displayed by your system. Screen content varies based on the type of chassis unit that you are using and the firmware versions and options that are installed.

1. Select the port to configure, or skip port configuration at the prompt:

```
Port Config:  
Enter port (INTA1-A14, EXT1-10):
```

If you wish to change settings for individual ports, enter the number of the port you wish to configure. To skip port configuration, press <Enter> without specifying any port.

**Note:** In the current software, external port characteristics cannot be configured using the Setup utility under factory default conditions. An error message is displayed when attempted.

2. Configure Gigabit Ethernet port flow parameters (if available).

The system prompts:

```
Gig Link Configuration:
Port Flow Control:
```

**Note:** In the current software, port flow control cannot be configured using the Setup utility under factory default conditions. Instead of a prompt, an error message is displayed when the port configuration is attempted.

3. Configure Gigabit Ethernet port autonegotiation mode (if available).

If you selected a port that has a Gigabit Ethernet connector, the system prompts:

```
Port Auto Negotiation:
Current Port EXT1 autonegotiation:      on
Enter new value ["on"/"off"]:
```

Enter on to enable port autonegotiation, off to disable it, or press <Enter> to keep the current setting.

**Note:** In the current software, autonegotiation cannot be changed for external ports using the Setup utility under factory default conditions. Instead of a configuration prompt, an error message is displayed when external port configuration is attempted.

4. The system prompts you to configure the next port:

```
Enter port (INTA1-A14, EXT1-10):
```

When you are through configuring ports, press <Enter> without specifying any port. Otherwise, repeat the steps in this section.

---

## Setup Part 3: IP Configuration

The system prompts for IP parameters.

### IP Interfaces

The Setup utility allows one optional IPv4 management interface and/or one optional IPv6 management interface to be configured on the SI4093. The IP address assigned to each interface provides the SI4093 with an IP presence on their respective management networks. The administrator can use the configured IP addresses to connect to the SI4093 for remote configuration.

**Note:** IP management interfaces operate under VLAN 4095, which is reserved for management functions and cannot be used in attached data domains.

1. Select the IP interface to configure, or skip interface configuration at the prompt:

```
IP Config:
IP interfaces:
Enter interface number: (125, 127)
```

If you wish to configure an IPv4 management interface, select interface 127. To configure an IPv6 management interface, select interface 126. To skip IP interface configuration, press <Enter> without typing an interface number and go to [“Default Gateways” on page 33](#).

2. If configuring an IPv4 management interface (interface 127):
  - a. Enter the IP address in IPv4 dotted decimal notation:

```
Enter new IP address:
```

To keep the current setting (if any is displayed), press <Enter>.

- b. At the prompt, enter the IPv4 subnet mask in dotted decimal notation:

```
Enter new subnet mask:
```

To keep the current setting (if any is displayed), press <Enter>.

- c. At the prompt, enter the VLAN for the interface:

```
Current VLAN: 4095
Enter new VLAN [1-4095]:
```

To keep the current setting, press <Enter>.

**Note:** In the current software, the IPv4 management interface VLAN cannot be changed using the Setup utility under factory default conditions. An error message is displayed when you attempt to change the setting.

- d. At the prompt, enter y to enable the IP interface, or n to leave it disabled:

```
Enable IP interface? [y/n]
```

3. If configuring an IPv6 management interface (interface 125):
  - a. Enter the IP address in IPv6 hexadecimal notation (see [“IPv6 Address Format” on page 106](#)):

```
Enter new IP address:
```

To keep the current setting (if any is displayed), press <Enter>.

- b. At the prompt, enter the IPv6 anycast address if desired:

```
Enter anycast if <IPv6 address> is anycast|<CR>:
```

To keep the current setting (if any is displayed), press <Enter>.

- c. At the prompt, enter the IPv6 prefix length:

```
Enter new Prefix length [1-128]:
```

To keep the current setting (if any is displayed), press <Enter>.

- d. At the prompt, enter the VLAN for the interface:

```
Current VLAN: 4095  
Enter new VLAN [1-4095]:
```

To keep the current setting, press <Enter>.

**Note:** In the current software, the IPv4 management interface VLAN cannot be changed using the Setup utility under factory default conditions. An error message is displayed when you attempt to change the setting.

- e. At the prompt, enter y to enable the IP interface, or n to leave it disabled:

```
Enable IP interface? [y/n]
```

4. The system prompts you to configure another interface:

```
Enter interface number: (125, 127)
```

Repeat the steps in this section until all desired management interfaces have been configured. When all interfaces have been configured, press <Enter> without specifying any interface number.



## Default Gateways

1. At the prompt, select an IP default gateway for configuration, or skip default gateway configuration:

```
IP default gateways:
Enter default gateway number: (3, 4)
```

Enter the number for the IP default gateway to be configured. To skip default gateway configuration, press <Enter> without typing a gateway number and go to [“Setup Part 4: Final Steps”](#) on page 33.

**Note:** In the current software, default gateway 4 cannot be configured using the Setup utility under factory default conditions. An error message is displayed when gateway 4 is selected.

2. At the prompt, enter the IPv4 address for the selected default gateway:

```
Current IP address: 0.0.0.0
Enter new IP address:
```

Enter the IPv4 address in dotted decimal notation, or press <Enter> without specifying an address to accept the current setting.

3. At the prompt, enter y to enable the default gateway, or n to leave it disabled:

```
Enable default gateway? [y/n]
```

4. The system prompts you to configure another default gateway:

```
Enter default gateway number: (3, 4)
```

Repeat the steps in this section until all default gateways have been configured. When all default gateways have been configured, press <Enter> without specifying any number.

---

## Setup Part 4: Final Steps

1. When prompted, decide whether to restart Setup or continue to the final steps:

```
Would you like to run from top again? [y/n]
```

Enter y to restart the Setup utility from the beginning, or n to continue.

2. When prompted, decide whether you wish to review the configuration changes:

```
Review the changes made? [y/n]
```

Enter y to review the changes made during this session of the Setup utility. Enter n to continue without reviewing the changes. We recommend that you review the changes.

3. Next, decide whether to apply the changes at the prompt:

```
Apply the changes? [y/n]
```

Enter y to apply the changes, or n to continue without applying. Changes are normally applied.

4. At the prompt, decide whether to make the changes permanent:

```
Save changes to flash? [y/n]
```

Enter y to save the changes to flash. Enter n to continue without saving the changes. Changes are normally saved at this point.

5. If you do not apply or save the changes, the system prompts whether to abort them:

```
Abort all changes? [y/n]
```

Enter y to discard the changes. Enter n to return to the “Apply the changes?” prompt.

---

## Optional Setup for Telnet Support

**Note:** This step is optional. Perform this procedure only if you are planning on connecting to the SI4093 through a remote Telnet connection.

Telnet is disabled by default. To change the setting, use the following configuration command:

```
SI 4093# configure terminal
SI 4093(config)# [no] access telnet enable
```

---

## Chapter 4. Administrative Security

This chapter discusses different methods of securing local and remote administration on the SI4093 10Gb System Interconnect Module (SI4093):

- [“Changing the System Passwords” on page 35](#)
- [“Secure Shell and Secure Copy” on page 36](#)
- [“End User Access Control” on page 41](#)
- [“Protected Mode” on page 43](#)

---

### Changing the System Passwords

Access to the SI4093 command line interface is controlled through the use of a login. Once you are connected to the SI4093, you are prompted to enter a login name and its associated password. By default, three log-ins are available:

- The user

The user login has limited control of the SI4093. Through a user account, you can view system information and statistics, but you can't make configuration changes.

The default username is: `user`

The default password is: `user`

- The administrator

The administrator login has complete access to all menus, information, and configuration commands, including the ability to change both the user and administrator passwords.

The default username is: `admin`

The default password is: `admin`

- An alternate administrator:

The default username is: `USERID`

The default password is: `PASSWORD` (with a zero)

This admin-level account occupies end-user ID 1 (see [“End User Access Control” on page 41](#)).

It is recommended that you change the passwords after initial setup and as regularly as required under your network security policies.

This user password can be changed from the user account. The administrator account can change all passwords, as shown in the following procedure.

1. Log-in to the SI4093.

When prompted, enter the administrator username and password:

**Note:** If the administrator password has been unexpectedly changed and lost, call your technical support representative for help using the password fix-up mode.

2. Access the configuration mode:

```
SI 4093> enable
SI 4093# configure terminal
SI 4093(config)#
```

The `enable` command initiates Privileged EXEC mode, and the `configure terminal` command readies the SI4093 for basic configuration. The system prompt changes to indicate the current command mode.

3. Set the new user password:

```
SI 4093(config)# access user user-password
```

This command will prompt for the required information: the current *administrator* password, the new user password (up to 128 characters), and confirmation of the new user password.

4. Set the new administrator “admin” password:

```
SI 4093(config)# access user administrator-password
```

This command will prompt for required information: current administrator password, new administrator password (up to 128 characters), and confirmation of the new administrator password.

5. Set the new alternate administrator “USERID” password:

```
SI 4093(config)# access user 1 password
```

This command will prompt for required information: current administrator password, new administrator password (up to 128 characters), and confirmation of the new administrator password.

---

## Secure Shell and Secure Copy

Because using Telnet does not provide a secure connection for managing a SI4093, Secure Shell (SSH) and Secure Copy (SCP) features have been included for SI4093 management. SSH and SCP use secure tunnels to encrypt and secure messages between a remote administrator and the SI4093.

- **SSH** is a protocol that enables remote administrators to log securely into the SI4093 over a network to execute management commands. The SI4093 supports SSH version 2.0 and above.  
By default, SSH is *enabled* on the SI4093.
- **SCP** is typically used to copy files securely from one device to another. SCP uses SSH for encryption of data on the network. On the SI4093, SCP is used to download and upload the system configuration via secure channels.  
By default, SCP is *disabled* on the SI4093.

## Configuring SSH/SCP

By default, SSH is enabled and SCP is disabled. To change the setting, use the following procedures.

**Note:** SCP requires SSH to remain enabled.

### To Enable or Disable the SSH Feature

Begin a Telnet session from the Console port and enter the following commands:

```
SI 4093> enable
SI 4093# configure terminal
SI 4093(config)# [no] ssh enable
```

The `enable` command initiates Privileged EXEC mode, and the `configure terminal` command readies the SI4093 for basic configuration. The system prompt changes to indicate the current command mode.

### To Enable or Disable SCP Apply and Save

Enter the following command from the configuration prompt to enable or disable the SCP `putcfg_apply` and `putcfg_apply_save` commands:

```
SI 4093(config)# [no] ssh scp-enable
```

## Configuring the SCP Administrator Password

To configure the SCP-only administrator password, enter the following command from the configuration prompt (the default SCP-only password is `admin`):

```
SI 4093(config)# [no] ssh scp-password
Changing SCP-only Administrator password; validation required...
Enter current administrator password: <password>
Enter new SCP-only administrator password: <new password>
Re-enter new SCP-only administrator password: <new password>
New SCP-only administrator password accepted.
```

## Using SSH and SCP Client Commands

This section shows the format for using some common client commands.

### To Log In to the SI4093 from the Client

Syntax:

```
>> ssh [-4|-6] <SI4093 IP address>  
-OR-  
>> ssh [-4|-6] <login name>@<SI4093 IP address>
```

**Note:** The -4 option (the default) specifies that an IPv4 address on the SI4093 will be used. The -6 option specifies IPv6.

Example:

```
>> ssh scpadmin@205.178.15.157
```

### To Copy the SI4093 System Configuration File to the SCP Host

Syntax:

```
>> scp [-4|-6] <username>@<SI4093 IP address>:getcfg <local filename>
```

Example:

```
>> scp scpadmin@205.178.15.157:getcfg ad4.cfg
```

### To Load a SI4093 System Configuration File from the SCP Host

Syntax:

```
>> scp [-4|-6] <local filename> <username>@<SI4093 IP address>:putcfg
```

Example:

```
>> scp ad4.cfg scpadmin@205.178.15.157:putcfg
```

## To Save the Configuration

When loading a configuration file to the SI4093, the commands in the file are automatically applied to the current configuration. However, the commands are not saved, and will be lost when the SI4093 is rebooted unless saved to the system's FLASH memory. The appropriate commands may be entered using SCP.

Syntax:

```
>> scp [-4|-6] <local filename> <username>@<SI4093 IP address>:putcfg_apply_save
```

Example:

```
>> scp ad4.cfg scpadmin@205.178.15.157:putcfg_apply_save
```

The `putcfg_apply_save` command is usually preferred over `putcfg` because the SCP session is not in an interactive mode.

## To Copy the SI4093 Software Image and Boot Files to the SCP Host

Syntax:

```
>> scp [-4|-6] <username>@<SI4093 IP address>:getimg1 <local filename>  
>> scp [-4|-6] <username>@<SI4093 IP address>:getimg2 <local filename>  
>> scp [-4|-6] <username>@<SI4093 IP address>:getboot <local filename>
```

Example:

```
>> scp scpadmin@205.178.15.157:getimg1 6.1.0_os.img
```

## To Load SI4093 System Configuration Files from the SCP Host

Syntax:

```
>> scp [-4|-6] <local filename> <username>@<SI4093 IP address>:putimg1  
>> scp [-4|-6] <local filename> <username>@<SI4093 IP address>:putimg2  
>> scp [-4|-6] <local filename> <username>@<SI4093 IP address>:putboot
```

Example:

```
>> scp 6.1.0_os.img scpadmin@205.178.15.157:putimg1
```

## SSH and SCP Encryption of Management Messages

The following encryption and authentication methods are supported for SSH and SCP:

- Server Host Authentication: 1024-bit RSA host key
- Key Exchange: diffie-hellman-group1-sha1, diffie-hellman-group14-sha1
- Encryption: 3des-cbc, aes128-cbc, aes128-ctr, arcfour, arcfour128, arcfour256, blowfish-cbc, rijndael128-cbc
- MAC: hmac-md5, hmac-md5-96, hmac-sha1, hmac-sha1-96
- User Authentication: Local password authentication, LDAP, RADIUS, TACACS+

## Generating the RSA Host Key for SSH Access

To support the SSH feature, an RSA host key is required. The host key is 1024 bits and is used to identify the SI4093.

When SSH is first enabled, the SI4093 automatically generates the RSA host key and stores it in FLASH memory.

To manually create an RSA host key, enter the following command via the SI4093 Console port (the command is not available via external Telnet connection)

```
SI 4093(config)# ssh generate-host-key
```

When the SI4093 reboots, it will retrieve the host key from the FLASH memory.

**Note:** The SI4093 will perform only one session of key/cipher generation at a time. Thus, an SSH/SCP client will not be able to log in if the system is performing key generation at that time. Also, key generation will fail if an SSH/SCP client is logging in at that time.

## SSH/SCP Integration with RADIUS Authentication

SSH/SCP is integrated with RADIUS authentication. After the RADIUS server is enabled on the SI4093, all subsequent SSH authentication requests will be redirected to the specified RADIUS servers for authentication. The redirection is transparent to the SSH clients.

## SSH/SCP Integration with TACACS+ Authentication

SSH/SCP is integrated with TACACS+ authentication. After the TACACS+ server is enabled on the SI4093, all subsequent SSH authentication requests will be redirected to the specified TACACS+ servers for authentication. The redirection is transparent to the SSH clients.



---

## End User Access Control

IBM Networking OS allows an administrator to define end user accounts that permit end users to perform operation tasks via the SI4093 CLI commands. Once end user accounts are configured and enabled, the SI4093 requires username/password authentication.

For example, an administrator can assign a user, who can then log into the SI4093 and perform operational commands (effective only until the next SI4093 reboot).

## Considerations for Configuring End User Accounts

- A maximum of 10 user IDs are supported on the SI4093.
- IBM Networking OS supports end-user account for the Console port, Telnet, and SSH version 2 (or above) access to the SI4093.
- If RADIUS authentication is used, the user password on the Radius server will override the user password on the SI4093. Also note that the password change command modifies only the user password on the SI4093 and has no effect on the user password on the Radius server. Radius authentication and user password cannot be used concurrently to access the SI4093.
- Passwords can be up to 128 characters in length for TACACS, RADIUS, Telnet, SSH, and Console port access.

## Strong Passwords

The administrator can require use of Strong Passwords for users to access the SI4093. Strong Passwords enhance security because they make password guessing more difficult.

The following rules apply when Strong Passwords are enabled:

- Minimum length: 8 characters; maximum length: 14 characters
- Must contain at least one uppercase alphabet
- Must contain at least one lowercase alphabet
- Must contain at least one number
- Must contain at least one special character:

Supported special characters: ! " # % & ' ( ) ; < = > ? [ \ ] \* + , - . / : ^ \_ { | } ~

When strong password is enabled, users can still access the SI4093 using the old password but will be advised to change to a strong password while attempting to log in.

Strong password requirement can be enabled using the following command:

```
SI 4093 # access user strong-password enable
```

The administrator can choose the number of days allowed before each password expires. When a strong password expires, the user is allowed to log in one last time (last time) to change the password. A warning provides advance notice for users to change the password.

## User Access Control Menu

The end-user access control commands allow you to configure end-user accounts.

Up to 10 user IDs can be configured. Use the following commands to define any user name and set the user password at the resulting prompts:

```
SI 4093(config)# access user 2 name <1-64 characters>
SI 4093(config)# access user 2 password

Changing user1 password; validation required:
Enter current admin password: <current administrator password>
Enter new user1 password: <new user password of up to 128 characters>
Re-enter new user1 password: <new user password>
New user1 password accepted.
```

**Note:** User 1 is pre-configured for administrator-level access, with a login name of USERID and password of PASSWORD (with a zero). This user ID cannot be disabled, nor can the name or access level be changed. Only the password can be changed.

### Defining a User's Access Level

The end user is by default assigned to the user access level (also known as class of service, or CoS). CoS for all user accounts have global access to all resources except for User CoS, which has access to view only resources that the user owns. For more information, see [Table 4 on page 47](#).

To change the user's level, select one of the following options:

```
SI 4093(config)# access user 2 level {user|operator|administrator}
```

**Note:** The administrator access level for User 1 cannot be changed.

### Validating a User's Configuration

```
SI 4093# show access user uid 2
```

### Enabling or Disabling a User

An end user account must be enabled before the SI4093 recognizes and permits login under the account. Once enabled, the SI4093 requires any user to enter both username and password.

```
SI 4093(config)# [no] access user 2 enable
```

**Note:** User 1 cannot be disabled.

## Listing Current Users

The following command displays defined user accounts and whether or not each user is currently logged into the SI4093.

```
SI 4093# show access user

Usernames:
  user      - enabled      - offline
  oper      - disabled     - offline
  admin     - Always Enabled - online      1 session.
Current User ID table:
  1: name USERID , ena, cos admin , password valid, offline
```

## Logging In to an End User Account

Once an end user account is configured and enabled, the user can login to the SI4093 by using the username/password combination. The degree of SI4093 access is determined by the Class of Service established for the end user account.

---

## Protected Mode

Protected Mode settings allow the SI4093 administrator to block the management module from making configuration changes that affect system operation. The SI4093 retains control over those functions.

The following management module functions are disabled when Protected Mode is turned on:

- External Ports: Enabled/Disabled
- External management over all ports: Enabled/Disabled
- Restore Factory Defaults
- New Static IP Configuration

In this release, configuration of the functions listed above are restricted to the local SI4093 when you turn Protected Mode on. In future releases, individual control over each function may be added.

**Note:** Before you turn Protected Mode on, make sure that external management (Telnet) access to one of the IP interfaces on the SI4093 is enabled.

Use the following Privileged EXEC Configuration mode command to turn Protected Mode on:

```
SI 4093(config)# protected-mode enable
```

If you lose access to the SI4093 through the external ports, use the Console port to connect directly to the SI4093, and configure an IP interface with Telnet access to reestablish access.



---

## Chapter 5. Authentication & Authorization Protocols

Secure SI4093 management is needed for environments that perform significant management functions across the Internet. The following are some of the functions for secured IPv4 management and device access:

- [“RADIUS Authentication and Authorization” on page 45](#)
- [“TACACS+ Authentication” on page 49](#)
- [“LDAP Authentication and Authorization” on page 53](#)

**Note:** IBM Networking OS 7.7 does not support IPv6 for RADIUS, TACACS+ or LDAP.

---

### RADIUS Authentication and Authorization

The SI4093 supports the RADIUS (Remote Authentication Dial-in User Service) method to authenticate and authorize remote administrators for managing the SI4093. This method is based on a client/server model. The Remote Access Server (RAS)—the SI4093—is a client to the back-end database server. A remote user (the remote administrator) interacts only with the RAS, not the back-end server and database.

RADIUS authentication consists of the following components:

- A protocol with a frame format that utilizes UDP over IP (based on RFC 2138 and 2866)
- A centralized server that stores all the user authorization information
- A client (in this case, the SI4093 is the client)

The SI4093—acting as the RADIUS client—communicates to the RADIUS server to authenticate and authorize a remote administrator using the protocol definitions specified in RFC 2138 and 2866. Transactions between the client and the RADIUS server are authenticated using a shared key that is not sent over the network. In addition, the remote administrator passwords are sent encrypted between the RADIUS client (the SI4093) and the back-end RADIUS server.

### How RADIUS Authentication Works

1. Remote administrator connects to the SI4093 and provides user name and password.
2. Using Authentication/Authorization protocol, the SI4093 sends request to authentication server.
3. Authentication server checks the request against the user ID database.
4. Using RADIUS protocol, the authentication server instructs the SI4093 to grant or deny administrative access.

## Configuring RADIUS on the SI4093

Use the following procedure to configure Radius authentication on your SI4093.

1. Configure the IPv4 addresses of the Primary and Secondary RADIUS servers, and enable RADIUS authentication.

```
SI 4093(config)# radius-server primary-host 10.10.1.1
SI 4093(config)# radius-server secondary-host 10.10.1.2
SI 4093(config)# radius-server enable
```

2. Configure the RADIUS secret.

```
SI 4093(config)# radius-server primary-host 10.10.1.1 key <1-32 character secret>
SI 4093(config)# radius-server secondary-host 10.10.1.2 key <1-32 character secret>
```

### Statement 21:



### CAUTION

If you configure the RADIUS secret using any method other than through the Console port, the secret may be transmitted over the network as clear text.

3. If desired, you may change the default UDP port number used to listen to RADIUS.

The well-known port for RADIUS is 1645.

```
SI 4093(config)# radius-server port <UDP port number>
```

4. Configure the number retry attempts for contacting the RADIUS server, and the timeout period.

```
SI 4093(config)# radius-server retransmit 3
SI 4093(config)# radius-server timeout 5
```

## RADIUS Authentication Features in IBM Networking OS

IBM Networking OS supports the following RADIUS authentication features:

- Supports RADIUS client on the SI4093, based on the protocol definitions in RFC 2138 and RFC 2866.
- Allows a RADIUS secret password of up to 32 characters.
- Supports *secondary authentication server* so that when the primary authentication server is unreachable, the SI4093 can send client authentication requests to the secondary authentication server. Use the following command to show the currently active RADIUS authentication server:

```
SI 4093# show radius-server
```

- Supports user-configurable RADIUS server retry and time-out values:
  - Time-out value = 1-10 seconds
  - Retries = 1-3

The SI4093 will time out if it does not receive a response from the RADIUS server within 1-10 seconds. The SI4093 automatically retries connecting to the RADIUS server 1-3 times before it declares the server down.
- Supports user-configurable RADIUS application port. The default is UDP port 1645. UDP port 1812, based on RFC 2138, is also supported.
- Allows network administrator to define privileges for one or more specific users to access the SI4093 at the RADIUS user database.

## User Accounts

The user accounts listed in [Table 4](#) can be defined in the RADIUS server dictionary file.

*Table 4. User Access Levels*

Account	Description and Tasks Performed	Default Password
Level: User Name: <code>user</code>	The User has no direct responsibility for SI4093 management. They can view all system status information and statistics but cannot make any configuration changes to the system.	<code>user</code>
Level: Operator Name: <code>oper</code>	In addition to User capabilities, the Operator has limited system management access, including the ability to make temporary, operational configuration changes to some SI4093 features, and to reset SI4093 ports (other than management ports).	<code>oper</code>
Level: Admin Name: <code>admin</code>	The super-user Administrator has complete access to all menus, information, and configuration commands on the SI4093, including the ability to change both the user and administrator passwords.	<code>admin</code>
Level: Admin Name: <code>USERID</code>	An alternate administrator account. This admin-level account occupies end-user ID 1 (see <a href="#">“End User Access Control” on page 41</a> ).	<code>PASSWORD (with a zero)</code>

## RADIUS Attributes for IBM Networking OS User Privileges

When the user logs in, the SI4093 authenticates his/her level of access by sending the RADIUS access request, that is, the client authentication request, to the RADIUS authentication server.

If the remote user is successfully authenticated by the authentication server, the SI4093 will verify the *privileges* of the remote user and authorize the appropriate access.

All user privileges, other than those assigned to the Administrator, have to be defined in the RADIUS dictionary. RADIUS attribute 6 which is built into all RADIUS servers defines the administrator. The file name of the dictionary is RADIUS vendor-dependent. The following RADIUS attributes are defined for IBM Networking OS user privileges levels:

Table 5. IBM Networking OS-proprietary Attributes for RADIUS

User Level/Name	User-Service-Type	Value
User / user	Vendor-supplied	255
Operator / oper	Vendor-supplied	252
Administrator / admin	Vendor-supplied	6
Administrator / USERID	Vendor-supplied	6

## RADIUS Backdoor

The administrator has a number of options to allow *backdoor* access via Telnet and SSH. When enabled, the backdoor allows the administrator to log in using the *noradius* user name and the regular SI4093 administrator password. Two options are available:

- Secure backdoor permits remote backdoor access only when the RADIUS server cannot be reached. This option is disabled by default.
- Regular backdoor permits remote backdoor access at any time, regardless of the RADIUS server status. This option also is disabled by default.

**Note:** The RADIUS backdoor is always available from the local Console port, regardless of remote backdoor settings.

Remote backdoor options can be enabled or disabled using the following CLI commands:

```
SI 4093(config)# [no] radius-server secure-backdoor      (Backdoor only when server is down)
SI 4093(config)# [no] radius-server backdoor            (Backdoor always available)
```



---

## TACACS+ Authentication

IBM Networking OS supports authentication, authorization, and accounting with networks using the Cisco Systems TACACS+ protocol. The SI4093 functions as the Network Access Server (NAS) by interacting with the remote client and initiating authentication and authorization sessions with the TACACS+ access server. The remote user is defined as someone requiring management access to the SI4093 either through a data or management port.

TACACS+ offers the following advantages over RADIUS:

- TACACS+ uses TCP-based connection-oriented transport; whereas RADIUS is UDP-based. TCP offers a connection-oriented transport, while UDP offers best-effort delivery. RADIUS requires additional programmable variables such as re-transmit attempts and time-outs to compensate for best-effort transport, but it lacks the level of built-in support that a TCP transport offers.
- TACACS+ offers full packet encryption whereas RADIUS offers password-only encryption in authentication requests.
- TACACS+ separates authentication, authorization and accounting.

## How TACACS+ Authentication Works

TACACS+ works much in the same way as RADIUS authentication as described on [page 45](#).

1. Remote administrator connects to the SI4093 and provides user name and password.
2. Using Authentication/Authorization protocol, the SI4093 sends request to authentication server.
3. Authentication server checks the request against the user ID database.
4. Using TACACS+ protocol, the authentication server instructs the SI4093 to grant or deny administrative access.

During a session, if additional authorization checking is needed, the SI4093 checks with a TACACS+ server to determine if the user is granted permission to use a particular command.

## TACACS+ Authentication Features in IBM Networking OS

Authentication is the action of determining the identity of a user, and is generally done when the user first attempts to log in to a device or gain access to its services. IBM Networking OS supports ASCII inbound login to the device. PAP, CHAP and ARAP login methods, TACACS+ change password requests, and one-time password authentication are not supported.

### Authorization

Authorization is the action of determining a user's privileges on the device, and usually takes place after authentication.

The default mapping between TACACS+ authorization levels and IBM Networking OS management access levels is shown in [Table 6](#). The authorization levels listed in this table must be defined on the TACACS+ server.

Table 6. Default TACACS+ Authorization Levels

IBM Networking OS Account Name	TACACS+ Level
user	0
oper	3
admin	6
USERID (administrator)	6

Alternate mapping between TACACS+ authorization levels and IBM Networking OS management access levels is shown in [Table 7](#). Use the following command to use the alternate TACACS+ authorization levels:

```
SI 4093(config)# tacacs-server privilege-mapping
```

Table 7. Alternate TACACS+ Authorization Levels

IBM Networking OS Account Name	TACACS+ Level
user	0–1
oper	6–8
admin	14–15
USERID (administrator)	14–15

If the remote user is successfully authenticated by the authentication server, the SI4093 verifies the *privileges* of the remote user and authorizes the appropriate access.

## Backdoor

The administrator has a number of options to allow *backdoor* access via Telnet and SSH. When enabled, the backdoor allows the administrator to log in using the `notacacs` user name and the regular SI4093 administrator password. Two options are available:

- Secure backdoor permits remote backdoor access only when the TACACS+ server cannot be reached. This option is disabled by default.
- Regular backdoor permits remote backdoor access at any time, regardless of the TACACS+ server status. This option also is disabled by default.

**Note:** The TACACS+ backdoor is always available from the local Console port, regardless of remote backdoor settings.

Remote backdoor options can be enabled or disabled using the following CLI commands:

```
SI 4093(config)# [no] tacacs-server secure-backdoor      (Backdoor only when server is down)
SI 4093(config)# [no] tacacs-server backdoor            (Backdoor always available)
```

## Accounting

Accounting is the action of recording a user's activities on the device for the purposes of billing and/or security. It follows the authentication and authorization actions. If the authentication and authorization is not performed via TACACS+, there are no TACACS+ accounting messages sent out.

You can use TACACS+ to record and track software login access, configuration changes, and interactive commands.

The SI4093 supports the following TACACS+ accounting attributes:

- `protocol` (console/telnet/ssh)
- `start_time`
- `stop_time`
- `elapsed_time`
- `disc-cause`

## Command Authorization and Logging

When TACACS+ Command Authorization is enabled, N/OS configuration commands are sent to the TACACS+ server for authorization. Use the following command to enable TACACS+ Command Authorization:

```
SI 4093(config)# tacacs-server command-authorization
```

When TACACS+ Command Logging is enabled, N/OS configuration commands are logged on the TACACS+ server. Use the following command to enable TACACS+ Command Logging:

```
SI 4093(config)# tacacs-server command-logging
```

The following examples illustrate the format of IBM Networking OS commands sent to the TACACS+ server:

```
authorization request, cmd=shell, cmd-arg=interface ip
accounting request, cmd=shell, cmd-arg=interface ip
authorization request, cmd=shell, cmd-arg=enable
accounting request, cmd=shell, cmd-arg=enable
```

## Configuring TACACS+ Authentication on the SI4093

1. Configure the IPv4 addresses of the Primary and Secondary TACACS+ servers, and enable TACACS authentication.

```
SI 4093(config)# tacacs-server primary-host 10.10.1.1
SI 4093(config)# tacacs-server secondary-host 10.10.1.2
SI 4093(config)# tacacs-server enable
```

2. Configure the TACACS+ secret and second secret.

```
SI 4093(config)# tacacs-server primary-host 10.10.1.1 key <1-32 character secret>
SI 4093(config)# tacacs-server secondary-host 10.10.1.2 key <1-32 character secret>
```

### Statement 21:



### CAUTION

**If you configure the TACACS+ secret using any method other than a direct Console port connection, the secret may be transmitted over the network as clear text.**

3. If desired, you may change the default TCP port number used to listen to TACACS+. The well-known port for TACACS+ is 49.

```
SI 4093(config)# tacacs-server port <TCP port number>
```

4. Configure the number of retry attempts, and the timeout period.

```
SI 4093(config)# tacacs-server retransmit 3
SI 4093(config)# tacacs-server timeout 5
```

---

## LDAP Authentication and Authorization

IBM Networking OS supports the LDAP (Lightweight Directory Access Protocol) method to authenticate and authorize remote administrators to manage the SI4093. LDAP is based on a client/server model. The SI4093 acts as a client to the LDAP server. A remote user (the remote administrator) interacts only with the SI4093, not the back-end server and database.

LDAP authentication consists of the following components:

- A protocol with a frame format that utilizes TCP over IP
- A centralized server that stores all the user authorization information
- A client (in this case, the SI4093 is the client)

Each entry in the LDAP server is referenced by its Distinguished Name (DN). The DN consists of the user-account name concatenated with the LDAP domain name. If the user-account name is John, the following is an example DN:

```
uid=John,ou=people,dc=domain,dc=com
```

If the remote user is successfully authenticated by the authentication server, the SI4093 verifies the *privileges* of the remote user and authorizes the appropriate access.

## LDAP Backdoor

The administrator has can allow *backdoor* access via Telnet and SSH. When enabled, the backdoor allows the administrator to log in using the `noldap` user name and the regular SI4093 administrator password at any time. This option is disabled by default.

**Note:** The LDAP backdoor is always available from the local Console port, regardless of the remote backdoor setting.

Remote backdoor can be enabled or disabled using the following CLI commands:

```
SI 4093(config)# [no] ldap-server backdoor (Backdoor always available)
```

## Configuring the LDAP Server

SI4093 user groups and user accounts must reside within the same domain. On the LDAP server, configure the domain to include SI4093 user groups and user accounts, as follows:

- User Accounts:  
Use the *uid* attribute to define each individual user account.
- User Groups:  
Use the *members* attribute in the *groupOfNames* object class to create the user groups. The first word of the common name for each user group must be equal to the user group names defined in the SI4093, as follows:
  - admin
  - oper
  - user

## Configuring LDAP Authentication on the SI4093

1. Turn LDAP authentication on, then configure the Primary and Secondary LDAP servers.

```
SI 4093(config)# ldap-server enable
SI 4093(config)# ldap-server primary-host 10.10.1.1
SI 4093(config)# ldap-server secondary-host 10.10.1.2
```

2. Configure the domain name.

```
SI 4093(config)# ldap-server domain <ou=people,dc=my-domain,dc=com>
```

3. If desired, you may change the default TCP port number used to listen to LDAP. The well-known port for LDAP is 389.

```
SI 4093(config)# ldap-server port <1-65000>
```

4. Configure the number of retry attempts for contacting the LDAP server, and the timeout period.

```
SI 4093(config)# ldap-server retransmit 3
SI 4093(config)# ldap-server timeout 10
```

---

## Chapter 6. Access Control Lists

Access Control Lists (ACLs) are filters that permit or deny traffic for security purposes. They can also be used with QoS to classify and segment traffic in order to provide different levels of service to different traffic types. Each filter defines the conditions that must match for inclusion in the filter, and also the actions that are performed when a match is made.

IBM Networking OS 7.7 supports the following ACLs:

- IPv4 ACLs

Up to 256 ACLs are supported for networks that use IPv4 addressing. IPv4 ACLs are configured using the following CLI command:

```
SI 4093(config)# access-control list <IPv4 ACL number> ?
```

- IPv6 ACLs

Up to 128 ACLs are supported for networks that use IPv6 addressing. IPv6 ACLs are configured using the following CLI command:

```
SI 4093(config)# access-control list6 <IPv6 ACL number> ?
```

---

## Summary of Packet Classifiers

ACLs allow you to classify packets according to a variety of content in the packet header (such as the source address, destination address, source port number, destination port number, and others). Once classified, packet flows can be identified for more processing.

Regular ACLs allow you to classify packets based on the following packet attributes:

- Ethernet header options (for regular ACLs only)
  - Source MAC address
  - Destination MAC address
  - VLAN number and mask
  - Ethernet type (ARP, IPv4, MPLS, RARP, etc.)
  - Ethernet Priority (the IEEE 802.1p Priority)
- IPv4 header options (for regular ACLs only)
  - Source IPv4 address and subnet mask
  - Destination IPv4 address and subnet mask
  - Type of Service value
  - IP protocol number or name as shown in [Table 8](#):

*Table 8. Well-Known Protocol Types*

Number	Protocol Name
1	icmp
2	igmp
6	tcp
17	udp
89	ospf
112	vrrp



- TCP/UDP header options (for all ACLs)
  - TCP/UDP application source port as shown in [Table 9](#).

*Table 9. Well-Known Application Ports*

Port	TCP/UDP Application	Port	TCP/UDP Application	Port	TCP/UDP Application
20	ftp-data	79	finger	179	bgp
21	ftp	80	http	194	irc
22	ssh	109	pop2	220	imap3
23	telnet	110	pop3	389	ldap
25	smtp	111	sunrpc	443	https
37	time	119	nntp	520	rip
42	name	123	ntp	554	rtsp
43	whois	143	imap	1645/1812	Radius
53	domain	144	news	1813	Radius
69	tftp	161	snmp	1985	Accounting
70	gopher	162	snmptrap		hsrp

- TCP/UDP application destination port and mask as shown in [Table 9](#).
- TCP/UDP flag value as shown in [Table 10](#).

*Table 10. Well-Known TCP flag values*

Flag	Value
URG	0x0020
ACK	0x0010
PSH	0x0008
RST	0x0004
SYN	0x0002
FIN	0x0001

- Packet format (for regular ACLs only)
  - Ethernet format (eth2, SNAP, LLC)
  - Ethernet tagging format
  - IP format (IPv4)
- Egress port packets (for all ACLs)

---

## Summary of ACL Actions

Once classified using ACLs, the identified packet flows can be processed differently. For each ACL, an *action* can be assigned. The action determines how the SI4093 treats packets that match the classifiers assigned to the ACL. SI4093 ACL actions include the following:

- Pass or Drop the packet
- Re-mark the packet with a new DiffServ Code Point (DSCP)
- Re-mark the 802.1p field
- Set the COS queue

---

## Assigning Individual ACLs to a Port

Once you configure an ACL, you must assign the ACL to the appropriate ports. Each port can accept multiple ACLs, and each ACL can be applied for multiple ports. ACLs can be assigned individually, or in groups.

To assign an individual ACLs to a port, use the following IP Interface Mode commands:

```
SI 4093(config)# interface port <port>
SI 4093(config-ip)# access-control list <IPv4 ACL number>
SI 4093(config-ip)# access-control list6 <IPv6 ACL number>
```

When multiple ACLs are assigned to a port, higher-priority ACLs are considered first, and their action takes precedence over lower-priority ACLs. ACL order of precedence is discussed in the next section.

To create and assign ACLs in groups, see [“ACL Groups” on page 59](#).

---

## ACL Order of Precedence

When multiple ACLs are assigned to a port, they are evaluated in numeric sequence, based on the ACL number. Lower-numbered ACLs take precedence over higher-numbered ACLs. For example, ACL 1 (if assigned to the port) is evaluated first and has top priority.

If multiple ACLs match the port traffic, only the action of the one with the lowest ACL number is applied. The others are ignored.

The ACL number is the sole factor in determining ACL order of precedence. The order in which ACLs are applied to a port does not affect the order of precedence, nor does the ACL Group number (see [“ACL Groups” on page 59](#)), the order in which an ACL is assigned to an ACL Group, or the order in which the ACL Group is assigned to a port.

If no assigned ACL matches the port traffic, no ACL action is applied.

---

## ACL Groups

To assist in organizing multiple ACLs and assigning them to ports, you can place ACLs into ACL Groups, thereby defining complex traffic profiles. ACLs and ACL Groups can then be assigned on a per-port basis. Any specific ACL can be assigned to multiple ACL Groups, and any ACL or ACL Group can be assigned to multiple ports. If, as part of multiple ACL Groups, a specific ACL is assigned to a port multiple times, only one instance is used. The redundant entries are ignored.

- **Individual ACLs**

The SI4093 supports up to 256 ACLs. Each ACL defines one filter rule for matching traffic criteria. Each filter rule can also include an action (permit or deny the packet). For example:

<b>ACL 1:</b> VLAN = 1 SIP = 10.10.10.1 (255.255.255.0) Action = permit
--

- **Access Control List Groups**

An Access Control List Group (ACL Group) is a collection of ACLs. For example:

ACL Group 1
<b>ACL 1:</b> VLAN = 1 SIP = 10.10.10.1 (255.255.255.0) Action = permit
<b>ACL 2:</b> VLAN = 2 SIP = 10.10.10.2 (255.255.255.0) Action = deny
<b>ACL 3:</b> Priority = 7 DIP = 10.10.10.3 (255.255.255.0) Action = permit

ACL Groups organize ACLs into traffic profiles that can be more easily assigned to ports. The SI4093 supports up to 256 ACL Groups.

**Note:** ACL Groups are used for convenience in assigning multiple ACLs to ports. ACL Groups have no effect on the order in which ACLs are applied (see [“ACL Order of Precedence” on page 58](#)). All ACLs assigned to the port (whether individually assigned or part of an ACL Group) are considered as individual ACLs for the purposes of determining their order of precedence.

---

## Assigning ACL Groups to a Port

To assign an ACL Group to a port, use the following commands:

```
SI 4093(config)# interface port <port>
SI 4093(config-ip)# access-control group <ACL group number>
```

---

## ACL Metering and Re-Marking

You can define a profile for the aggregate traffic flowing through the SI4093 by configuring a QoS meter (if desired) and assigning ACLs to ports.

**Note:** When you add ACLs to a port, make sure they are ordered correctly in terms of precedence (see [“ACL Order of Precedence” on page 58](#)).

Actions taken by an ACL are called *In-Profile* actions. You can configure additional In-Profile and Out-of-Profile actions on a port. Data traffic can be metered, and re-marked to ensure that the traffic flow provides certain levels of service in terms of bandwidth for different types of network traffic.

### Metering

QoS metering provides different levels of service to data streams through user-configurable parameters. A meter is used to measure the traffic stream against a traffic profile which you create. Thus, creating meters yields In-Profile and Out-of-Profile traffic for each ACL, as follows:

- **In-Profile**—If there is no meter configured or if the packet conforms to the meter, the packet is classified as In-Profile.
- **Out-of-Profile**—If a meter is configured and the packet does not conform to the meter (exceeds the committed rate or maximum burst rate of the meter), the packet is classified as Out-of-Profile.

Using meters, you set a Committed Rate in Kbps (1000 bits per second in each Kbps). All traffic within this Committed Rate is In-Profile. Additionally, you can set a Maximum Burst Size that specifies an allowed data burst larger than the Committed Rate for a brief period. These parameters define the In-Profile traffic.

Meters keep the sorted packets within certain parameters. You can configure a meter on an ACL, and perform actions on metered traffic, such as packet re-marking.

### Re-Marking

Re-marking allows for the treatment of packets to be reset based on new network specifications or desired levels of service. You can configure the ACL to re-mark a packet as follows:

- Change the DSCP value of a packet, used to specify the service level that traffic should receive.
- Change the 802.1p priority of a packet.

---

## ACL Port Mirroring

For regular ACLs, packets that match an ACL on a specific port can be mirrored to another SI4093 port for network diagnosis and monitoring.

The source port for the mirrored packets cannot be a portchannel, but may be a member of a portchannel.

The destination port to which packets are mirrored must be a physical port.

If the ACL has an action (permit, drop, etc.) assigned, it cannot be used to mirror packets for that ACL.

Use the following command to add mirroring to an ACL:

```
SI 4093(config)# access-control list <ACL number> mirror port <destination port>
```

The ACL must be also assigned to its target ports as usual (see [“Assigning Individual ACLs to a Port” on page 58](#), or [“Assigning ACL Groups to a Port” on page 60](#)).

---

## Viewing ACL Statistics

ACL statistics display how many packets have “hit” (matched) each ACL. Use ACL statistics to check filter performance or to debug the ACL filter configuration.

You must enable statistics for each ACL that you wish to monitor:

```
SI 4093(config)# access-control list <ACL number> statistics
```

---

## ACL Configuration Examples

### ACL Example 1

Use this configuration to block traffic to a specific host. All traffic that ingresses on port EXT1 is denied if it is destined for the host at IP address 100.10.1.1

1. Configure an Access Control List.

```
SI 4093(config)# access-control list 1 ipv4 destination-ip-address 100.10.1.1
SI 4093(config)# access-control list 1 action deny
```

2. Add ACL 1 to port EXT1.

```
SI 4093(config)# interface port ext1
SI 4093(config-if)# access-control list 1
SI 4093(config-if)# exit
```

## ACL Example 2

Use this configuration to block traffic from a network destined for a specific host address. All traffic that ingresses in port EXT2 with source IP from class 100.10.1.0/24 and destination IP 200.20.2.2 is denied.

1. Configure an Access Control List.

```
SI 4093(config)# access-control list 2 ipv4 source-ip-address 100.10.1.0
255.255.255.0
SI 4093(config)# access-control list 2 ipv4 destination-ip-address 200.20.2.2
255.255.255.255
SI 4093(config)# access-control list 1 action deny
```

2. Add ACL 2 to port EXT2.

```
SI 4093(config)# interface port ext2
SI 4093(config-if)# access-control list 2
SI 4093(config-if)# exit
```

## ACL Example 3

This configuration blocks traffic from a network that is destined for a specific egress port. All traffic that ingresses port EXT1 from the network 100.10.1.0/24 and is destined for port 3 is denied.

1. Configure an Access Control List.

```
SI 4093(config)# access-control list 4 ipv4 source-ip-address 100.10.1.0
255.255.255.0
SI 4093(config)# access-control list 4 egress-port 3
SI 4093(config)# access-control list 4 action deny
```

2. Add ACL 4 to port EXT1.

```
SI 4093(config)# interface port ext1
SI 4093(config-if)# access-control list 4
SI 4093(config-if)# exit
```

---

## Chapter 7. Updating the System Software

The SI4093 software image is the executable code that directs system operation. A version of the image comes pre-installed on the device. As new versions of the image are released, you can upgrade the software running on your SI4093.

The typical upgrade process for the software image consists of the following steps:

- Determine the version of software currently installed on your system.
- Get the latest version of software available for your system.
- Load a new software image and boot image onto an FTP or TFTP server on your network.
- Transfer the new images to your SI4093.
- Specify the new software image as the one which will be loaded into SI4093 memory the next time a system reset occurs.
- Reset the SI4093.

Detailed instructions for this typical upgrade process are covered in the rest of this chapter.

---

### Determining the Current Software Version

To determine the software version currently used on the system, enter the following CLI command:

```
SI 4093# show boot
```

The software version will be shown in the resulting display.

---

### Getting the Latest SI4093 Software

To get the latest version of software supported for your SI4093, go to the following website:

<http://www.ibm.com/systems/support>

---

## Loading New Software to Your SI4093



**CAUTION:**

Although the standard software installation process as described in this section is all that is necessary in most cases, installing certain versions of N/OS requires additional, special steps to be taken prior to and/or after software installation. Check the *Release Notes* available for the specific version of the software you wish to install, and follow all applicable instructions. Failing to heed the full instructions in the *Release Notes* may cause unexpected behavior in the SI4093.

The SI4093 can store up to two different system software images (called `image1` and `image2`) as well as special boot software (called `boot`). When you load new software, you must specify where it should be placed: either into `image1`, `image2`, or `boot`.

For example, if your active image is currently loaded into `image1`, you would probably load the new image software into `image2`. This lets you test the new software and reload the original active image (stored in `image1`), if needed.



**CAUTION:**

When you upgrade the SI4093 software image, always load both the new boot image and the new software image before you reset the system. If you do not load a new boot image, your SI4093 might not boot properly (to recover, see [“Recovering from a Failed Upgrade” on page 66](#)).

To load a new software image to your SI4093, you will need the following:

- The image and boot software loaded on an FTP or TFTP server on your network.  
**Note:** Be sure to download both the new boot file and the new image file.
- The hostname or IP address of the FTP or TFTP server  
**Note:** The DNS parameters must be configured if specifying hostnames.
- The name of the new software image or boot file

When the software requirements are met, use the following procedure to download the new software to your SI4093:

1. In Privileged EXEC mode, enter the following command, specifying the method for loading the software (TFTP or FTP) and the SI4093 destination (`image1`, `image2`, or `boot-image`):

```
SI 4093# copy {tftp|ftp} {image1|image2|boot-image}
```

2. When prompted, enter the hostname or IP address of the FTP or TFTP server.

```
Address or name of remote host: <name or IP address>
```



3. When prompted, enter the name of the new software file on the server.

```
Source file name: <filename>
```

The exact form of the name will vary by server. However, the file location is normally relative to the FTP or TFTP directory (for example, `tftpboot`).

4. If required by the FTP or TFTP server, enter the appropriate username and password.
5. The SI4093 will prompt you to confirm your request.  
Once confirmed, the software will begin loading into the SI4093.
6. When loading is complete, use the following commands to enter Global Configuration mode and select which software image (`image1` or `image2`) you want to run in system memory for the next reboot:

```
SI 4093# configure terminal
SI 4093(config)# boot image {image1|image2}
```

The system will then verify which image is set to be loaded at the next reset:

```
Next boot will use switch software image1 instead of image2.
```

7. Reboot the SI4093 to run the new software:

```
SI 4093(config)# reload
```

The system prompts you to confirm your request. Once confirmed, the system will reboot to use the new software.

---

## Recovering from a Failed Upgrade

The Boot Management menu allows you to perform fundamental device management operations, such as selecting which software image will be loaded, resetting the SI4093 to factory defaults, or recovering from a failed software download.

Use the following procedure to recover from a failed software upgrade.

1. Connect a PC to the serial Console port of the SI4093.
2. Open a terminal emulator program that supports XModem Download (for example, HyperTerminal, SecureCRT, PuTTY) and select the following port characteristics:
  - Speed: 9600 bps
  - Data Bits: 8
  - Stop Bits: 1
  - Parity: None
  - Flow Control: None
3. To access the Boot Management menu, you must interrupt the boot process from the Console port. Boot the SI4093, and when the system begins displaying Memory Test progress (a series of dots), press **<Shift B>**.

The Boot Management menu will appear:

```
Resetting the System ...
Memory Test .....

Boot Management Menu
1 - Change booting image
2 - Change configuration block
3 - Xmodem download
4 - Exit

Please choose your menu option: 1
Current boot image is 1. Enter image to boot: 1 or 2: 2
Booting from image 2
```

4. On the resulting menu, select **3** for Xmodem download. When you see the following message, change the port characteristics in your terminal emulation software to 115200 bps:

```
## Switch baudrate to 115200 bps and press ENTER ...
```

5. Press **<Enter>** to set the system into download accept mode. When the readiness meter displays (a series of "C" characters), start XModem on your terminal emulator.

6. Select the Boot Image to download. The XModem initiates the file transfer. When the download is complete, a message similar to the following is displayed:

```
yzModem - CRC mode, 62494(SOH)/0(STX)/0(CAN) packets, 6 retries
Extracting images ... Do *NOT* power cycle the switch.
**** VMLINUX ****
Un-Protected 10 sectors
Erasing Flash..... done
Writing to Flash.....done
Protected 10 sectors
**** RAMDISK ****
Un-Protected 44 sectors
Erasing Flash..... done
Writing to Flash.....done
Protected 44 sectors
**** BOOT CODE ****
Un-Protected 8 sectors
Erasing Flash..... done
Writing to Flash.....done
Protected 8 sectors
```

7. When you see the following message, change the port characteristics in your terminal emulation software to 9600 bps:

```
## Switch baudrate to 9600 bps and press ESC ...
```

8. Press the Escape key (<Esc>) to re-display the Boot Management menu.
9. Select **3** to start a new XModem Download. When you see the following message, change the port characteristics in your terminal emulation software to 115200 bps:

```
## Switch baudrate to 115200 bps and press ENTER ...
```

10. Press <Enter> to continue the download.

11. Select the N/OS Image to download. The XModem initiates the file transfer. When the download is complete, a message similar to the following is displayed:

```
yzModem - CRC mode, 27186(SOH)/0(STX)/0(CAN) packets, 6 retries

Extracting images ... Do *NOT* power cycle the switch.

**** Switch OS ****

Please choose the Switch OS Image to upgrade [1|2|n] :
```

12. Select the image number to load the new image (1 or 2). It is recommended that you select 1. A message similar to the following is displayed:

```
Switch OS Image 1 ...

Un-Protected 27 sectors

Erasing Flash..... done

Writing to Flash.....done

Protected 27 sectors
```

13. When you see the following message, change the port characteristics in your terminal emulation software to 9600 bps:

```
## Switch baudrate to 9600 bps and press ESC ...
```

14. Press the Escape key (<Esc>) to re-display the Boot Management menu.
15. Select 4 to exit and boot using the new image.

---

## Chapter 8. System License Keys

License keys determine the number of available ports on the SI4093.

### Basic License

The basic license is active by default on the SI4093. It provides the use of 24 ports as follows:

- **Ports INTA1 through INTA14**  
Internal 1/10 Gbps Ethernet ports that connect to servers within the chassis.
- **Ports EXT1 through EXT10**  
External 1/10 Gbps SFP+ Ethernet ports for uplink to the network.

All ports in the basic license are assigned to SPAR-1 by default. After initial start-up, the external ports are pre-configured by default to form a single, loop-free IEEE 802.1 Link Aggregation Group (LAG) that allows for plug-and-play operation. In this state, you can attach as many of the available uplink ports as required to meet application bandwidth requirements to the upstream device.

### Optional Upgrade License 1

For expansion, upgrade license 1 provides up to 46 ports. In addition to all ports provided by the basic license, the following are available:

- **Ports INTB1 through INTB14**  
Internal 1/10 Gbps Ethernet ports that connect to the servers within the chassis.
- **Port EXT15 through EXT22**  
By default, each of the two external QSFP+ ports is configured for operation as four 10 Gbps Ethernet uplinks to the network using the appropriate system divider cables.

However, if high-bandwidth connections are preferred, each QSFP+ port can independently configured to operate in undivided 40 Gbps Ethernet mode (see [“QSFP+ Ports” on page 85](#)).

The extra ports provided by upgrade 1 are assigned to SPAR-2 by default. This isolates them from the SPAR-1 ports provided by the basic license, and helps ensure that newly attached domains maintain separation when the upgrade is activated.

As with the basic license, the external ports available with upgrade license 1 are initially grouped together into their own LAG.

### Optional Upgrade License 2

Upgrade license 2 provides up to 64 ports. In addition to all ports provided by the basic license and upgrade license 1, the following are available:

- **Ports INTC1 through INTC14**  
Internal 1/10 Gbps Ethernet ports that connect to the servers within the chassis.
- **Port EXT11 through Port EXT14**  
External 1/10 Gbps SFP+ Ethernet ports for uplink to the network.

The extra ports provided by the upgrade are assigned to SPAR-3 by default. This isolates them from the SPAR-1 and SPAR-2 ports provided by the other licenses, and helps ensure that newly attached domains maintain separation when the upgrade is activated.

As with the other licenses, the external ports available with upgrade license 2 are initially grouped together into their own LAG.

Upgrade license 2 requires that upgrade license 1 be installed first.

---

## Obtaining Activation Keys

The upgrade licenses can be acquired using the *IBM System x Features on Demand* (FoD) website:

<http://www.ibm.com/systems/x/fod/>

You can also use the website to review and manage licenses, and to obtain additional help, if required.

**Note:** An IBM ID and password are required to log into the FoD website. If you do not yet have an IBM ID, you can register at the website.

Activation keys are provided as files that must be uploaded to the SI4093. To acquire an activation key, use the FoD website to purchase an Authorization Code. You will need to provide the unique ID (UID) of the specific SI4093 where the key will be installed. The UID is the last 12 characters of the SI4093 serial number. This serial number is located on the Part Number (PN) label and is also displayed during successful login to the device.

When available, download the activation key file from the FoD site.

---

## Installing Activation Keys

Once FoD activation key files have been acquired, they must be installed on the SI4093. The example below depicts use of the SI4093 Command Line Interface (CLI), but other device interfaces (such as SNMP) may also be used.

When installing licenses, please note the following requirements:

- The SI4093 must be reset to activate any newly installed licenses.
- The 64 Port License (Upgrade 2) will not function unless the 46 Port License (Upgrade 1) is also present. If installing both upgrades at the same time, upload both keys prior to resetting the SI4093.

To install activation keys, complete the following steps:

1. Log in to the SI4093.
2. At the CLI prompt, enter the following commands:

```
SI 4093> enable
SI 4093# configure terminal
SI 4093(config)# software-key
SI 4093(config)# enakey addr <server IP address> keyfile <key filename>
```

3. Follow the prompts to enter the appropriate parameters, including the file transfer protocol and server parameters.

**Note:** Repeat the `enakey` command for any additional keys being installed.

4. Once the key file has been uploaded to the SI4093, reset the device to activate any newly installed licenses.:

```
SI 4093(config)# reload
```

The system prompts you to confirm your request. Once confirmed, the system will reboot with the new licenses.

---

## Transferring Activation Keys

Licenses keys are based on the unique SI4093 device serial number and are non-transferable.

In the event that the SI4093 must be replaced, a new activation key must be acquired and installed. When the replacement is handled through IBM Service and Support, your original license will be transferred to the serial number of the replacement unit and you will be provided a new license key.





## Chapter 9. Switch Partition

### SPAR Overview

The SI4093 uses Switch Partition (SPAR) technology to facilitate the enforcement of multi-tenancy traffic segregation and security applications.

SPAR allows you to divide the SI4093 into up to eight different traffic zones, or *partitions*. Each SPAR represents a separate segment of the device's data plane hardware. Traffic in a given SPAR is not shared with other SPARs on the same device: the traffic in each SPAR remains entirely segregated from other SPARs for the entire duration of its transit through the SI4093.

Figure 4. Basic Switch Partitions on the SI4093

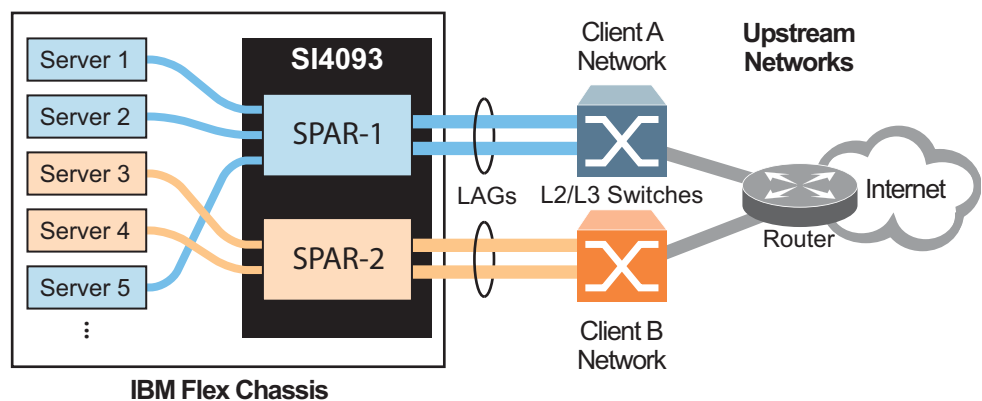

As shown in [Figure 4](#), each SPAR may be connected to its upstream network through separate L2/L3 routing or switching devices (recommended). Alternately, SPARs may be connected to the upstream network through a shared L2/L3 device with additional configuration.

By default, SI4093 ports are assigned to a specific SPAR based on the active system license keys (see [“System License Keys” on page 69](#)). Under the basic license, internal ports INTA1 through INTA14 and external ports EXT1 through EXT10 are available, and all are grouped into SPAR-1.

Each SPAR must include one or more internal server ports and one or more external uplink ports. However, if multiple external ports are to be included in a particular SPAR, they must first be configured as a Link Aggregation Group (LAG), thus operating together as a single logical port connected to the same upstream network entity. Any given SPAR cannot include multiple, independent (non-LAG) uplink ports.

Each internal or external port can be a member of only one SPAR at any given time. Because the SI4093 does not permit any SPAR to include multiple non-LAG uplink ports, the possibility of creating a broadcast loop is eliminated.

As part of the default Layer 2 Failover settings (see [page 165](#)), at least one uplink connection must be operational in order for the internal server ports to remain operational. This avoids situations where an internal server path is active but has no corresponding path to the external domains.

Configuring SPARs requires the following basic tasks:

1. Group the desired ports into a SPAR.
2. Set the SPAR mode: transparent mode or VLAN-aware mode.
3. Disable FDB learning on uplinks, if required.
4. Set the SPAR's default VLAN, if required.

These steps are described in detail in the remaining sections of this chapter.

---

## SPAR Ports Membership

### Default SPAR Ports

Each internal or external port can be a member of only one SPAR at any given time. By default, all available ports are automatically assigned to a SPAR in order to allow plug-and-play operation. The default SPAR configuration depends on which system license keys are installed (see ["System License Keys" on page 69](#)), and are summarized as follows:

- SPAR-1
  - Defined automatically by factory default at all license levels:
    - Internal ports INTA1–INTA10
    - External ports EXT1–EXT10 in LAG 65 with LACP admin key 1000
    - Uses default VLAN 4081 (reserved)
- SPAR-2
  - Defined automatically at license upgrades 1 and 2:
    - Internal ports INTB1–INTB14
    - External ports EXT15–EXT22 in LAG 66 with LACP admin key 1001
    - Uses default VLAN 4082 (reserved)
- SPAR-3
  - Defined automatically at license upgrade 2 only:
    - Internal ports INTC1–INTC14
    - External ports EXT11–EXT14 in LAG 67 with LACP admin key 1002
    - Uses default VLAN 4083 (reserved)

Regardless of the system license level, up to eight SPARs are available. You can reconfigure the port membership list for any SPAR, including default SPARs, to include any combination of ports available under the installed license: ports are not restricted to their default SPARs.

## Configuring SPAR Ports

Use the following commands in Privileged EXEC Configuration Mode to set port membership for any SPAR:

```
SI 4093(config)# spar <SPAR number (1-8)>
SI 4093(config-spar)# domain default member <internal port, list, or range>
SI 4093(config-spar)# uplink {port <external port>|portchannel <1-64>|adminkey <1-65535>}
SI 4093(config-spar)# exit
```

These commands relate as follows:

- The `spar` command selects the target SPAR for configuration.
- The `domain default member` command specifies the desired internal ports. At least one internal port must be specified.
- The `uplink` command specifies either an individual external uplink port, or a LAG consisting of multiple ports, identified by the admin key or portchannel ID.

When defining SPAR membership, if any of the desired ports is already a member of an existing SPAR, you must first remove those ports from their old SPAR. Likewise, if a desired external port is part of a LAG used on an existing SPAR, you must also remove the desired ports from their old LAG.

For example, to create SPAR-4 using ports INTA1, INTA2, EXT1, and EXT2 (which are part of SPAR-1 by default), use the following commands:

1. Select the contributor SPAR and remove the desired ports:

```
SI 4093(config)# spar 1
SI 4093(config-spar)# no domain default member inta1,inta2
SI 4093(config-spar)# no uplink port
SI 4093(config-spar)# exit
```

In this case, remove internal ports INTA1 and INTA2, and clear the external uplink. The entire uplink must be cleared because ports EXT1 and EXT2 are part of a LAG on the SPAR and cannot be removed independently of their LAG associates.

2. Remove the desired external ports from their old LAG, if any:

```
SI 4093(config)# interface port ext1-ext2
SI 4093(config-if)# default lacp
SI 4093(config-if)# exit
```

3. Repair SPAR-1 by returning the remainder of its external port LAG:

```
SI 4093(config)# spar 1
SI 4093(config-spar)# uplink adminkey 1000
SI 4093(config-spar)# exit
```

4. Place all desired external ports for the new SPAR into a new LAG:

```
SI 4093(config)# portchannel 68 lacp key 500 suspend-individual
SI 4093(config)# interface port ext1-ext2
SI 4093(config-if)# lacp key 500
SI 4093(config-if)# lacp mode active
SI 4093(config-if)# exit
```

**Note:** Multiple external ports cannot be added to a SPAR unless they are members of the same LAG. If only one external port is needed for the SPAR, no new LAG is required and this step can be omitted.

5. Assign the desired ports and enable SPAR-4:

```
SI 4093(config)# spar 4
SI 4093(config-spar)# domain default member inta1,inta2
SI 4093(config-spar)# uplink adminkey 500
SI 4093(config-spar)# enable
SI 4093(config-spar)# exit
```

**Note:** In this case, the LAG consisting of multiple external ports is added. If a single external port is preferred, the `uplink port <external port>` command would be used.

6. You can confirm the resulting configuration using the `show running-config` and `show lacp` information commands.

---

## SPAR Modes

Each SPAR can operate either in transparent mode (the default) or in advanced VLAN-aware mode.

### Transparent SPARs

By default, all available SPARs operate in transparent mode. With minimal initial configuration, this allows the SI4093 to be used as a plug-and-play device, suitable for low-touch, unmanaged environments. This facilitates quick installation and setup of chassis server modules in many deployments.

Transparent operation assumes the SI4093 is attached to a pre-configured upstream switch. In this topology, any configuration required for Layer 2 VLANs, FCoE, or IP routing is performed in the upstream network devices, or in the chassis server modules, or both. The SI4093 provides connectivity between the devices, but is transparent to the network and storage streams.

Transparent mode supports both IEEE 802.1 VLAN tagged and untagged frames without additional configuration.

Transparent SPARs are not aware of server VLANs. Each transparent SPAR operates as a single broadcast domain. Broadcast, multicast and unknown unicast traffic is delivered to all servers attached to the SPAR, regardless of their individual VLAN participation.

Any traffic from the servers that is not specifically destined for another internal server on the SPAR will be forwarded on the SPAR uplink. Outbound multicast traffic that originates from an internal server in the SPAR will be forwarded to all internal servers in the SPAR in addition to the SPAR uplink. Inbound multicast traffic received over the SPAR uplink will be forwarded to all servers in the SPAR.

Servers belonging to different SPARs cannot communicate directly through the SI4093, regardless of their VLAN membership. Instead, they must connect through their upstream devices.

Although transparent mode is used by default for each SPAR, the mode can be manually set using the following Privileged EXEC Configuration Mode commands:

```
SI 4093(config)# spar <SPAR number (1-8)>
SI 4093(config-spar)# domain mode passthrough
SI 4093(config-spar)# exit
```

When the SPAR mode is set as `passthrough` (transparent mode), any prior settings for VLAN-aware mode on the SPAR, such as local VLAN/port associations, are cleared.

## VLAN-Aware SPARs

Optionally, each SPAR can be independently configured to operate in VLAN-aware mode.

For any SPAR operating in VLAN-aware mode, multiple IEEE 802.1 VLAN groups are supported. This provides an additional level of Layer 2 traffic partitioning within the SPAR where VLAN separation must be enforced within the SPAR. This differs from the default transparent mode in which VLAN broadcasts are received by all servers in the SPAR regardless of their VLAN participation. VLAN-aware mode is useful in topologies where multitenancy occurs *within* the SPAR.

VLAN-aware mode supports up to 256 VLANs per SPAR.

## Configuring VLAN-Aware Mode

Use the following commands in Privileged EXEC Configuration Mode to configure VLAN-aware mode for any SPAR:

```
SI 4093(config)# spar <SPAR number (1-8)>
SI 4093(config-spar)# domain mode local
SI 4093(config-spar)# domain local <domain index (1-256)> vlan <VLAN ID (2-4094)>
SI 4093(config-spar)# domain local <domain index (1-256)> member <internal port, list, or range>
SI 4093(config-spar)# domain local <domain index (1-256)> enable
SI 4093(config-spar)# exit
```

These commands relate as follows:

- The `spar` command selects the target SPAR for configuration.
- The `domain mode local` command specifies VLAN-aware mode for the SPAR.
- The various `domain local` commands specify a VLAN ID and its member ports for one of up to 256 VLAN domains available for the SPAR.

In the following example, VLAN-aware mode is configured for an existing SPAR, assumed to be previously defined with ports INTA9–INTA14. The example shows the addition of three enforced VLAN domains using the following Privileged EXEC Configuration Mode commands:

1. Select the SPAR.

```
SI 4093(config)# spar 5
```

2. Specify the domain mode as `local` for VLAN-aware operation.

```
SI 4093(config-spar)# domain mode local
```

3. Configure the local VLAN domains and their member ports.

```
SI 4093(config-spar)# domain local 1 vlan 10
SI 4093(config-spar)# domain local 1 member inta9-inta10
SI 4093(config-spar)# domain local 1 enable
SI 4093(config-spar)# domain local 2 vlan 20
SI 4093(config-spar)# domain local 2 member inta11-inta12
SI 4093(config-spar)# domain local 2 enable
SI 4093(config-spar)# domain local 3 vlan 30
SI 4093(config-spar)# domain local 3 member inta13-inta14
SI 4093(config-spar)# domain local 3 enable
```

4. Exit the SPAR configuration mode.

```
SI 4093(config-spar)# exit
```

---

## Disabling FDB Learning on Uplinks

The recommended SPAR configurations are as follows:

- Transparent SPARs.
- VLAN-aware SPARs whose servers have no VLANs in common with other VLAN-aware SPARs on the SI4093.
- VLAN-aware SPARs whose servers may have VLANs in common with other VLAN-aware SPARs on the SI4093, and where the affected SPARs are connected to different upstream networks.

It is not recommended to connect more than one VLAN-aware SPAR to the same upstream network if servers on those SPARs use one or more of the same VLANs.

In the above scenario, traffic sent by an upstream server on a VLAN that is configured on multiple SPARs will be delivered to the servers on each SPAR via their respective uplink. But because the SI4093 uses a shared forwarding table (rather than one per-SPAR), the forwarding entry for the upstream server appears only once, pointing to the uplink for only one of the SPARs. This can lead to scenarios where traffic originating from one SPAR is not properly delivered to an upstream server. In such circumstances, it may be necessary to disable address learning on the affected uplinks.

The Host setting addresses this issue. When Host is enabled, address learning is disabled on uplink ports, and traffic originating from the SI4093 for all unknown destinations (including traffic to upstream destinations) will be forwarded to each SPAR's uplink. This setting should only be used when the conditions described above apply.

To enable or disable uplink learning globally for all SPARs on the SI4093, use the following command in Privileged EXEC Configuration Mode:

```
SI 4093(config)# [no] spar-global host-mode enable
```

---

## SPAR Default VLANs

Every SPAR, whether operating in transparent mode or VLAN-aware mode, is assigned a unique VLAN ID. This identifier is used for internal SI4093 purposes. SPAR uses the same pool of VLAN IDs available for other applications, from VLAN 2 to VLAN 4094 (default VLAN 1 and management VLAN 4095 are reserved).

The VLAN assigned to each SPAR must be unique. It cannot be used for any other application. Similarly, any VLAN used by another application cannot be assigned as the SPAR default VLAN.

Initial SPAR default VLAN configurations are based on the installed license keys (see [“System License Keys” on page 69](#)) as follows:

- SPAR-1 is assigned VLAN 4081 by default at all license levels.
- SPAR-2 is assigned VLAN 4082 by default, at license upgrades 1 and 2.
- SPAR-3 is assigned VLAN 4083 by default, at license upgrade 2.

The default VLAN can be changed using the following Privileged EXEC Configuration Mode commands:

```
SI 4093(config)# spar <SPAR number (1-8)>
SI 4093(config-spar)# domain default vlan <VLAN ID (2-4094)>
SI 4093(config-spar)# exit
```

---

## SPAR Restrictions

The following SPAR restrictions apply to other SI4093 features:

- When creating LAGs (static or LACP trunks) on the SI4093, you cannot include any ports that currently belong to an existing SPAR or to any other LAG. To create a LAG, ports must first be released from any associated SPARs and LAGs.
- ACLs defined on the SI4093 can be used for SPAR ports. However, an ACL cannot be shared across SPAR ports if:
  - An exit port is used as a filtering criteria and the exit port does not belong to the same SPAR as the port on which the ACL is applied.
  - A monitor port is used as a filtering criteria, and the monitor port does not belong to the same SPAR as the mirrored port and is not defined on the default switch.

These ACL restrictions apply to all ACLs defined in an ACL group.

- Layer 2 failover features can be configured on SPAR ports for manual monitoring when all ports defined within the trigger belong to the same SPAR.
- Before using the FIP snooping feature, you must manually disable FIP snooping for internal and external ports where *any* of the following conditions apply:
  - Disable for all transparent SPAR ports.
  - Disable for ports where FCoE traffic is not desired.
  - Disable for ports where transparent FCoE is acceptable.



## Example Configurations

### Quick-Deployment SPAR Example

This example assumes an unmanaged environment with the default transparent SPAR for quick-deployment plug-and-play purposes. The topology is that of [Figure 5](#).

Figure 5. Basic SI4093 Topology

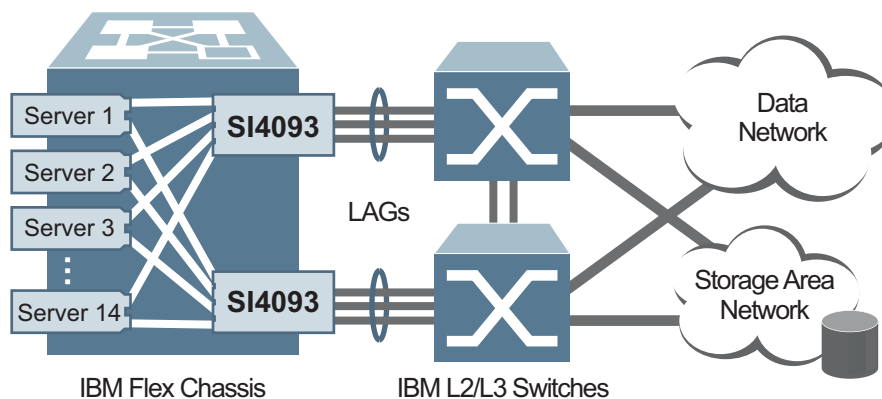

1. Prepare the system environment.  
In this deployment, servers and upstream L2/L3 switches must be installed and configured as desired, including any VLAN, routing, and FCoE features.
2. Install the SI4093 devices.  
Two SI4093 devices are installed in the IBM Flex chassis: one in I/O Bay 1 and 2. Installation is performed according to the product *User's Guide*.
3. Initialize the SI4093 devices
  - System access and initial setup for each installed SI4093 are performed as described in [“Administrative Access” on page 19](#), [“Initial Setup” on page 27](#).
  - Default passwords are changed as described in [“Administrative Security” on page 35](#).
4. Connect each SI4093 device to its corresponding upstream switch.  
By default, external ports EXT1 through EXT10 are activated on each SI4093 under the basic system license, and automatically configured in a LAG on SPAR-1. On each SI4093, connect two or more activated external ports to its upstream switch, depending on your bandwidth and redundancy requirements, and configure the ports on the upstream device for LAG operation.
5. Set the default VLAN ID on each SI4093, if necessary.  
By default, the VLAN ID for SPAR-1 is 4081. If this VLAN is in use on your network for a different purpose, specify an unused VLAN for use with SPAR-1. For example:

```
SI 4093(config)# spar 1
SI 4093(config-spar)# domain default vlan 400
SI 4093(config-spar)# exit
```

6. Converged Enhanced Ethernet (CEE) with transparent Fibre-Channel over Ethernet (FCoE) is globally enabled by default, reserving lossless bandwidth for SAN traffic that uses QoS priority 3. If FCoE is not required, or if QoS priority 3 traffic is used for a different purpose, turn CEE off:

```
SI 4093(config)# no cee enable
```

**Note:** Transparent FCoE does not install or enforce Fibre-Channel ACLs (FIP Snooping is disabled). For extended FCoE options, see [“Fibre Channel over Ethernet” on page 115](#).

## Transparent SPAR Example

This example includes configuration of a new SPAR (SPAR-4) in transparent mode. SPAR-4 will include member ports INTA1 and INTA2, and an external uplink LAG comprised of ports EXT1 and EXT2.

1. Because the desired ports are already in use by SPAR-1 by default, you must first release the desired ports:

```
SI 4093(config)# spar 1
SI 4093(config-spar)# no domain default member inta1,inta2
SI 4093(config-spar)# no uplink port
SI 4093(config-spar)# exit
```

The entire uplink must be cleared because ports EXT1 and EXT2 are part of a default LAG on SPAR-1 and cannot be removed independently of their LAG associates.

2. Move all desired external ports for the new SPAR into a new LAG:

```
SI 4093(config)# portchannel 68 lacp key 500 suspend-individual
SI 4093(config)# interface port ext1-ext2
SI 4093(config-if)# lacp key 500
SI 4093(config-if)# lacp mode active
SI 4093(config-if)# exit
```

**Note:** Multiple external ports cannot be added to a SPAR unless they are members of the same LAG. If only one external port is needed for the new SPAR, no new LAG is required: instead the old LAG must be cleared using the default `lacp` command.

3. Repair SPAR-1 by returning the remainder of its external port LAG:

```
SI 4093(config)# spar 1
SI 4093(config-spar)# uplink adminkey 1000
SI 4093(config-spar)# exit
```

4. Assign the desired ports to the new SPAR:

```
SI 4093(config)# spar 4
SI 4093(config-spar)# domain default member inta1,inta2
SI 4093(config-spar)# uplink adminkey 500
```

**Note:** In this case, the LAG consisting of multiple external ports is added. If a single external port is preferred, the `uplink port <external port>` command would be used.

5. Specify the domain mode as `passthrough` for transparent SPAR operation.

```
SI 4093(config-spar)# domain mode passthrough
```

**Note:** Transparent mode is the default for all SPARs. If the mode has not previously been changed, you can omit this step.

6. Configure the default VLAN ID, if required.

```
SI 4093(config-spar)# domain default vlan 421
```

The VLAN assigned to each SPAR must be unique. It cannot be used for any other application. Similarly, any VLAN used by another application cannot be assigned to a SPAR.

7. Enable the new SPAR and exit SPAR configuration mode:

```
SI 4093(config-spar)# enable
SI 4093(config-spar)# exit
```

8. You can confirm the resulting configuration using the `show running-config` command.

## VLAN-Aware SPAR Example

This example describes configuration of SPAR-5 for VLAN-aware mode.

1. Create SPAR-5:

```
SI 4093(config)# spar 5
```

2. Configure the SPAR default VLAN and add member ports.

```
SI 4093(config-spar)# domain default vlan 4085
SI 4093(config-spar)# domain default member inta9-inta14
SI 4093(config-spar)# uplink port ext3
```

In this example, the SPAR is configured for VLAN 4085, with internal ports INTA9–INTA14, and a single external port as the uplink. To specify a LAG as the uplink the `uplink portchannel` or `uplink adminkey` commands could be used.

**Note:** When defining SPAR ports, if any of the desired ports is already a member of an existing SPAR, you must first remove those ports from their old SPAR. Likewise, if a desired external port is part of a LAG, you must also remove the desired ports from their old LAG prior to assigning them as a SPAR uplink, or as part of a LAG being assigned as a SPAR uplink.

3. Specify the domain mode as `local` for VLAN-aware operation.

```
SI 4093(config-spar)# domain mode local
```

4. Configure local VLAN domains and their member ports.

```
SI 4093(config-spar)# domain local 1 vlan 10
SI 4093(config-spar)# domain local 1 member inta9-inta10
SI 4093(config-spar)# domain local 1 enable
SI 4093(config-spar)# domain local 2 vlan 20
SI 4093(config-spar)# domain local 2 member inta11-inta12
SI 4093(config-spar)# domain local 2 enable
SI 4093(config-spar)# domain local 3 vlan 30
SI 4093(config-spar)# domain local 3 member inta13-inta14
SI 4093(config-spar)# domain local 3 enable
```

5. Enable SPAR-5.

```
SI 4093(config-spar)# enable
```

6. Exit the SPAR configuration mode.

```
SI 4093(config-spar)# exit
```

## Chapter 10. QSFP+ Ports

QSFP+ ports are available with optional upgrade license 1. The QSFP+ ports support both 10GbE and 40GbE, as shown in [Table 11](#).

Table 11. QSFP+ Port Numbering

Physical Port Number	40GbE mode	10GbE mode
Port EXT15	Port EXT15	Ports EXT15-EXT18
Port EXT19	Port EXT19	Ports EXT19-EXT22

The following procedure allows you to change the QSFP+ port mode.

1. Display the current port mode for the QSFP+ ports.

```
SI 4093(config)# show boot qsfp-port-modes

QSFP ports booted configuration:
Port EXT15, EXT16, EXT17, EXT18 - 10G Mode
Port EXT19, EXT20, EXT21, EXT22 - 10G Mode

QSFP ports saved configuration:
Port EXT15, EXT16, EXT17, EXT18 - 10G Mode
Port EXT19, EXT20, EXT21, EXT22 - 10G Mode
```

2. Change the port mode to 40GbE. Select the physical port number.

```
SI 4093(config)# boot qsfp-40Gports EXT19
```

3. Verify the change.

```
SI 4093(config)# show boot qsfp-port-modes

QSFP ports booted configuration:
Port EXT15, EXT16, EXT17, EXT18 - 10G Mode
Port EXT19, EXT20, EXT21, EXT22 - 10G Mode

QSFP ports saved configuration:
Port EXT15, EXT16, EXT17, EXT18 - 10G Mode
Port EXT19 - 40G Mode
```

4. Reset the system.

```
SI 4093(config)# reload
```

5. Remove the configured port from QSFP+ mode to reset the ports to 10GbE mode

```
SI 4093(config)# no boot qsfp-40Gports <port number or a range of ports>
```



---

## Chapter 11. Ports and Trunking

Trunk groups can provide super-bandwidth, multi-link connections between the SI4093 and other trunk-capable devices. A trunk group is a group of ports that act together, combining their bandwidth to create a single, larger virtual link. This chapter provides configuration background and examples for trunking multiple ports together:

- “Trunking Overview” on page 87
- “Default Trunks” on page 88
- “Static Trunks” on page 89
- “Configurable Trunk Hash Algorithm” on page 92
- “Link Aggregation Control Protocol” on page 93

---

### Trunking Overview

When using port trunk groups between two devices, as shown in [Figure 6](#), you can create a virtual link between them, operating with combined throughput levels that depends on how many physical ports are included.

Two trunk types are available: static trunk groups (portchannel), and dynamic LACP trunk groups. Up to 64 trunks of each type are supported, depending of the number and type of available ports. Each trunk can include up to 16 member ports.

Figure 6. Port Trunk Group

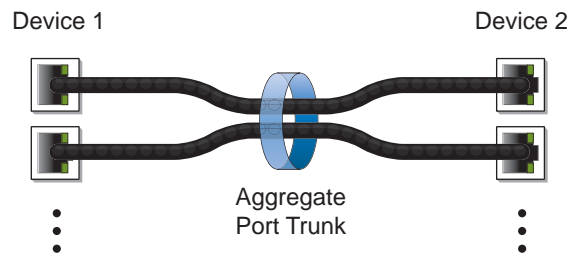

Trunk groups are also useful for connecting a SI4093 to IBM switches and third-party devices that support link aggregation, such as Cisco routers and switches with EtherChannel technology (*not* ISL trunking technology) and Sun's Quad Fast Ethernet Adapter. Trunk Group technology is compatible with these devices when they are configured manually.

Trunk traffic is statistically distributed among the ports in a trunk group, based on a variety of configurable options.

Also, since each trunk group is comprised of multiple physical links, the trunk group is inherently fault tolerant. As long as one connection between the devices is available, the trunk remains active and statistical load balancing is maintained whenever a port in a trunk group is lost or returned to service.

In [Figure 7](#), four ports are trunked together between the SI4093 and the enterprise routing device. Connectivity is maintained as long as one of the links remain active. The links to the server are also trunked, allowing the secondary NIC to take over in the event that the primary NIC link fails.

Figure 7. Trunking Ports for Link Redundancy

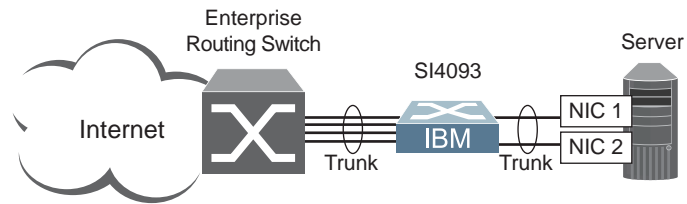

---

## Default Trunks

By default, all available external ports are automatically assigned to an LACP static LAG in order to allow plug-and-play operation. The default LAG configuration depends on which system license keys are installed (see ["System License Keys" on page 69](#)), and are summarized as follows:

- LAG 65  
Defined automatically by factory default at all license levels:
  - LACP admin key 1000
  - External ports EXT1–EXT10
- LAG 66  
Defined automatically at license upgrades 1 and 2:
  - LACP admin key 1001
  - External ports EXT15–EXT22
- LAG 67  
Defined automatically at license upgrade 2 only:
  - LACP admin key 1002
  - External ports EXT11–EXT14



---

## Static Trunks

### Before Configuring Static Trunks

When you create and enable a static trunk, the trunk members (ports) take on certain settings necessary for correct operation of the trunking feature.

Before you configure your trunk, you must consider these settings, along with specific configuration rules, as follows:

- Read the configuration rules provided in the section, [“Static Trunk Group Configuration Rules” on page 89.](#)”
- Determine which S14093 ports are to become *trunk members* (the specific ports making up the trunk).
- Ensure that the chosen ports are set to `enabled`.
- Ensure all member ports in a trunk have the same VLAN configuration.
- Consider how existing VLANs will be affected by the addition of a trunk.

### Static Trunk Group Configuration Rules

The trunking feature operates according to specific configuration rules. When creating trunks, consider the following rules that determine how a trunk group reacts in any network topology:

- All trunks must originate from one network entity and lead to one destination entity. For example, you cannot combine links from two different servers into one trunk group.
- Any physical S14093 port can belong to only one trunk group.
- Depending on port availability, the S14093 supports up to 16 ports in each trunk group.
- Internal ports (INTx) and external ports (EXTx) cannot become members of the same trunk group.
- Trunking from third-party devices must comply with Cisco® EtherChannel® technology.
- All trunk member ports must be assigned to the same VLAN configuration before the trunk can be enabled.
- If you change the VLAN settings of any trunk member, you cannot apply the change until you change the VLAN settings of all trunk members.
- When an active port is configured in a trunk, the port becomes a *trunk member* when you enable the trunk.
- All ports in static trunks must have the same link configuration (speed, duplex, flow control).
- When defining trunks, if any of the desired ports is already a member of an existing SPAR, you must first remove those ports from their old SPAR. Likewise, if a desired port is part of an existing trunk or LACP LAG, you must also remove the desired ports from their old trunk or LAG.

## Configuring a Static Port Trunk

In the example below, three ports are trunked between the SI4093 and an application switch.

Figure 8. Port Trunk Group Configuration Example

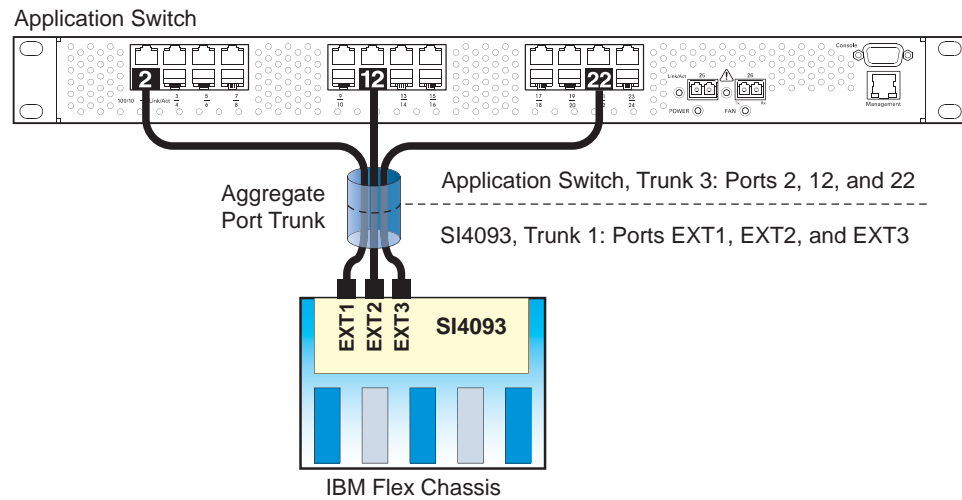

Prior to configuring each device in the above example, you must connect to the appropriate device as the administrator.

1. Connect the ports that will be members in the trunk group.
2. Configure the trunk using these steps on the SI4093:
  - a. Define a trunk group..

```
SI 4093(config)# portchannel 1 port ext1,ext2,ext3
SI 4093(config)# portchannel 1 enable
```

- b. Verify the configuration

```
# show portchannel information
```

Examine the resulting information. If any settings are incorrect, make appropriate changes.

3. Repeat the process on the application switch.

```
RS G8011(config)# portchannel 3 port 2,12,22
RS G8011(config)# portchannel 3 enable
```

Trunk group 1 (on the SI4093) is now connected to trunk group 3 on the application switch.

**Note:** In this example, a SI4093 and an IBM application switch are used. If a third-party device supporting link aggregation is used (such as Cisco routers and switches with EtherChannel technology or Sun's Quad Fast Ethernet Adapter), trunk groups on the third-party device should be configured manually. Connection problems could arise when using automatic trunk group negotiation on the third-party device.

4. Examine the trunking information on each device.

```
# show portchannel information
PortChannel 3: Enabled
Protocol-Static
port state:
  2: forwarding
 12: forwarding
 22: forwarding
```

Information about each port in each configured trunk group is displayed. Make sure that trunk groups consist of the expected ports and that each port is in the expected state.

---

## Configurable Trunk Hash Algorithm

Traffic in a trunk group is statistically distributed among member ports using a *hash* process where various address and attribute bits from each transmitted frame are recombined to specify the particular trunk port the frame will use. The SI4093 uses the RTAG7 model for trunk hashing.

The SI4093 can be configured to use a variety of hashing options. To achieve the most even traffic distribution, select options that exhibit a wide range of values for your particular network. Avoid hashing on information that is not usually present in the expected traffic, or which does not vary.

The SI4093 supports the following hashing options:

- Layer 2 source MAC address

```
SI 4093(config)# portchannel thash l2thash l2-source-mac-address
```

- Layer 2 destination MAC address

```
SI 4093(config)# portchannel thash l2thash l2-destination-mac-address
```

- Layer 2 source and destination MAC address

```
SI 4093(config)# portchannel thash l2thash l2-source-destination-mac
```

- Layer 3 IPv4/IPv6 source IP address

```
SI 4093(config)# portchannel thash l3thash l3-source-ip-address
```

- Layer 3 IPv4/IPv6 destination IP address (the default)

```
SI 4093(config)# portchannel thash l3thash l3-destination-ip-address
```

- Layer 3 source and destination IPv4/IPv6 address (the default)

```
SI 4093(config)# portchannel thash l3thash l3-source-destination-ip
```

- Layer 2 hash configuration

```
SI 4093(config)# portchannel thash l3thash l3-use-l2-hash
```

- Layer 4 port hash

```
SI 4093(config)# portchannel thash l4port
```

- Ingress port hash

```
SI 4093(config)# portchannel thash ingress
```

---

# Link Aggregation Control Protocol

## LACP Overview

Link Aggregation Control Protocol (LACP) is an IEEE 802.3ad standard for grouping several physical ports into one logical port (known as a dynamic trunk group or Link Aggregation Group) with any device that supports the standard. Please refer to IEEE 802.3ad-2002 for a full description of the standard.

IEEE 802.3ad allows standard Ethernet links to form a single Layer 2 link using the Link Aggregation Control Protocol (LACP). Link aggregation is a method of grouping physical link segments of the same media type and speed in full duplex, and treating them as if they were part of a single, logical link segment. If a link in a LACP trunk group fails, traffic is reassigned dynamically to the remaining link or links of the dynamic trunk group.

In general, LACP must be configured on both the SI4093 as well as on the connecting device. This section describes LACP on the SI4093. For configuring LACP on the connecting device, see the appropriate product documentation.

The SI4093 supports up to 64 LACP trunks, each with up to 16 ports.

**Note:** LACP implementation in IBM Networking OS does not support the Churn machine, an option used to detect if the port is operable within a bounded time period between the actor and the partner. Only the Marker Responder is implemented, and there is no marker protocol generator.

A port's Link Aggregation Identifier (LAG ID) determines how the port can be aggregated. The Link Aggregation ID (LAG ID) is constructed mainly from the *system ID* and the port's *admin key*, as follows:

- **System ID:** an integer value based on the SI4093's MAC address and the system priority assigned in the CLI.
- **Admin key:** a port's *admin key* is an integer value (1 - 65535) that you can configure in the CLI. Each SI4093 port that participates in the same LACP trunk group must have the same *admin key* value. The *admin key* is *local significant*, which means the partner device does not need to use the same *admin key* value.

For example, consider two devices, the SI4093 and a Partner switch, as shown in [Table 12](#).

Table 12. Actor vs. Partner LACP configuration

SI4093	Partner Switch
Port EXT1 (LAG = 65, admin key = 100)	Port 1 (admin key = 50)
Port EXT2 (LAG = 65, admin key = 100)	Port 2 (admin key = 50)
Port EXT3 (LAG = 66, admin key = 100)	Port 3 (admin key = 70)

In the configuration shown in [Table 12](#), the SI4093 ports EXT1 and EXT2 are aggregated to form an LACP trunk group with Partner switch ports 1 and 2. Only ports with the same LAG ID are aggregated in the trunk group. The SI4093 port EXT3 is not aggregated in the trunk group because it has a different LAG ID. Other ports configured with the same *admin key* on the SI4093 but with a different LAG ID (due to Partner switch *admin key* configuration or due to Partner switch MAC

address being different) can be aggregated in another trunk group. For instance, SI4093 port EXT3 can be aggregated in another trunk group with ports that have the same LAG ID as port EXT3.

To prevent SI4093 ports (with the same admin key) from aggregating in another trunk group, you can configure a trunk ID. Ports with the same admin key (although with different LAG IDs) compete to get aggregated into a trunk group. The LAG ID for the trunk group is decided based on the first port that is aggregated in the group. Ports with this LAG ID get aggregated and the other ports are placed in *suspended* mode. As per the configuration shown in [Table 12](#), if port EXT1 gets aggregated first, then the LAG ID of port EXT1 would be the LAG ID of the trunk. Port EXT3 would be placed in suspended mode. When in suspended mode, a port transmits only LACP data units (LACPDUs) and discards all other traffic.

A port may also be placed in suspended mode for the following reasons:

- When LACP is configured on the port but it stops receiving LACPDUs from the partner switch.
- When the port has a different LAG ID because of the partner switch MAC being different. For example: when the SI4093 is connected to two partners.

Trunk ID can be viewed using the following command:

```
SI 4093 # show lacp information
```

LACP provides for the controlled addition and removal of physical links for the link aggregation.

Each port in the SI4093 can have one of the following LACP modes.

- *off* (default)  
The user can configure this port in to a regular static trunk group.
- *active*  
The port is capable of forming an LACP trunk. This port sends LACPDU packets to partner system ports.
- *passive*  
The port is capable of forming an LACP trunk. This port only responds to the LACPDU packets sent from an LACP *active* port.

Each active LACP port transmits LACP data units (LACPDUs), while each passive LACP port listens for LACPDUs. During LACP negotiation, the admin key is exchanged. The LACP trunk group is enabled as long as the information matches at both ends of the link. If the admin key value changes for a port at either end of the link, that port's association with the LACP trunk group is lost.

When the system is initialized, all ports by default are in LACP *off* mode and are assigned unique *admin keys*. To make a group of ports available for aggregation, you assign them all the same *admin key*. You must set the port's LACP mode to *active* to activate LACP negotiation. You can set other port's LACP mode to *passive*, to reduce the amount of LACPDU traffic at the initial trunk-forming stage.

In the information displays, static trunks are listed as trunks 1 through 64. Dynamic trunks are listed as 65 through 128.

## Configuring LACP

Use the following procedure to configure LACP in order for port EXT1 and port EXT2 to participate in link aggregation.

1. Configure port parameters. All ports that participate in the LACP trunk group must have the same settings, including VLAN membership.
2. Define a portchannel by assigning an ID and an LACP admin key:

```
SI 4093(config)# portchannel 65 lacp key 100 suspend-individual
```

3. Select the ports and bind the LACP admin key. Only ports with the same admin key can form an LACP trunk group.

```
SI 4093(config)# interface port ext1-ext2
SI 4093(config-if)# lacp key 100
```

**Note:** If any of the desired ports is a member of an existing SPAR, you must first remove those ports from their old SPAR. Likewise, if a desired port is part of another LAG, you must also remove the desired ports from their old LAG (see [“Configuring SPAR Ports” on page 75](#)).

4. Set the LACP mode.

```
SI 4093(config-if)# lacp mode active
SI 4093(config-if)# exit
```





---

## Chapter 12. Quality of Service

Quality of Service (QoS) features allow you to allocate network resources to mission-critical applications at the expense of applications that are less sensitive to such factors as time delays or network congestion. You can configure your network to prioritize specific types of traffic, ensuring that each type receives the appropriate QoS level.

The following topics are discussed in this section:

- [“QoS Overview” on page 97](#)
- [“Using ACL Filters” on page 99](#)
- [“Using 802.1p Priorities to Provide QoS” on page 101](#)
- [“Queuing and Scheduling” on page 102](#)

---

### QoS Overview

QoS helps you allocate guaranteed bandwidth to critical applications, and limit bandwidth for less critical applications. Applications such as video and voice must have a certain amount of bandwidth to work correctly; using QoS, you can provide that bandwidth when necessary. Also, you can put a high priority on applications that are sensitive to timing out or those that cannot tolerate delay, assigning that traffic to a high-priority queue.

By assigning QoS levels to traffic flows on your network, you can ensure that network resources are allocated where they are needed most. QoS features allow you to prioritize network traffic, thereby providing better service for selected applications.

[Figure 9 on page 97](#) shows the basic QoS model used by the SI4093 10Gb System Interconnect Module (SI4093).

Figure 9. QoS Model

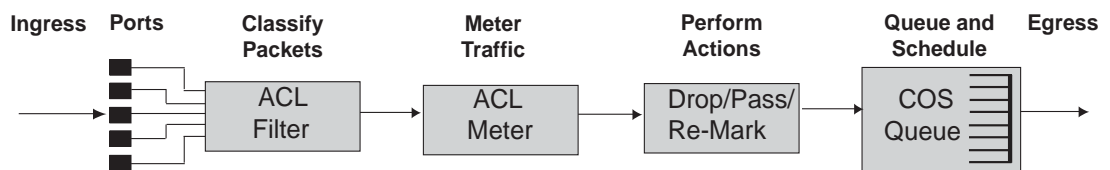

The SI4093 uses the Differentiated Services (DiffServ) architecture to provide QoS functions. DiffServ is described in IETF RFC 2474 and RFC 2475.

With DiffServ, you can establish policies for directing traffic. A policy is a traffic-controlling mechanism that monitors the characteristics of the traffic (for example, its source, destination, and protocol) and performs a controlling action on the traffic when certain characteristics are matched.

The SI4093 can classify traffic by reading the DiffServ Code Point (DSCP) or IEEE 802.1p priority value, or by using filters to match specific criteria. When network traffic attributes match those specified in a traffic pattern, the policy instructs the SI4093 to perform specified actions on each packet that passes through it. The packets are assigned to different Class of Service (COS) queues and scheduled for transmission.

The basic SI4093 QoS model works as follows:

- Classify traffic:
  - Read DSCP
  - Read 802.1p Priority
  - Match ACL filter parameters
- Meter traffic:
  - Define bandwidth and burst parameters
  - Select actions to perform on in-profile and out-of-profile traffic
- Perform actions:
  - Drop packets
  - Pass packets
  - Mark DSCP or 802.1p Priority
  - Set COS queue (with or without re-marking)
- Queue and schedule traffic:
  - Place packets in one of the available COS queues
  - Schedule transmission based on the COS queue weight

---

## Using ACL Filters

Access Control Lists (ACLs) are filters that allow you to classify and segment traffic, so you can provide different levels of service to different traffic types. Each filter defines conditions that packets must match for inclusion in a particular service class, and also the actions that are performed for matching traffic.

The SI4093 allows you to classify packets based on various parameters. For example:

- Ethernet—source MAC, destination MAC, VLAN number/mask, Ethernet type, priority
- IPv4—source IP address/mask, destination address/mask, type of service, IP protocol number
- IPv6—source IP address/prefix, destination address/prefix, next header, flow label, traffic class
- TCP/UPD—source port, destination port, TCP flag
- Packet format—Ethernet format, tagging format, IPv4, IPv6
- Egress port

For ACL details, see [“Access Control Lists” on page 55](#).

## Summary of ACL Actions

Actions determine how the traffic is treated. The SI4093 QoS actions include the following:

- Pass or Drop the packet
- Re-mark the packet with a new DiffServ Code Point (DSCP)
- Re-mark the 802.1p field
- Set the COS queue

## ACL Metering and Re-Marking

You can define a profile for the aggregate traffic flowing through the SI4093 by configuring a QoS meter (if desired) and assigning ACL Groups to ports. When you add ACL Groups to a port, make sure they are ordered correctly in terms of precedence.

Actions taken by an ACL are called *In-Profile* actions. You can configure additional In-Profile and Out-of-Profile actions on a port. Data traffic can be metered, and re-marked to ensure that the traffic flow provides certain levels of service in terms of bandwidth for different types of network traffic.

## Metering

QoS metering provides different levels of service to data streams through user-configurable parameters. A meter is used to measure the traffic stream against a traffic profile which you create. Thus, creating meters yields In-Profile and Out-of-Profile traffic for each ACL, as follows:

- **In-Profile**—If there is no meter configured or if the packet conforms to the meter, the packet is classified as In-Profile.
- **Out-of-Profile**—If a meter is configured and the packet does not conform to the meter (exceeds the committed rate or maximum burst rate of the meter), the packet is classified as Out-of-Profile.

**Note:** Metering is not supported for IPv6 ACLs. All traffic matching an IPv6 ACL is considered in-profile for re-marking purposes.

Using meters, you set a Committed Rate in Kbps (1000 bits per second in each Kbps). All traffic within this Committed Rate is In-Profile. Additionally, you can set a Maximum Burst Size that specifies an allowed data burst larger than the Committed Rate for a brief period. These parameters define the In-Profile traffic.

Meters keep the sorted packets within certain parameters. You can configure a meter on an ACL, and perform actions on metered traffic, such as packet re-marking.

## Re-Marking

Re-marking allows for the treatment of packets to be reset based on new network specifications or desired levels of service. You can configure the ACL to re-mark a packet as follows:

- Change the DSCP value of a packet, used to specify the service level traffic should receive.
- Change the 802.1p priority of a packet.

---

## Using 802.1p Priorities to Provide QoS

### 802.1p Overview

IBM Networking OS provides Quality of Service functions based on the priority bits in a packet's VLAN header. (The priority bits are defined by the 802.1p standard within the IEEE 802.1q VLAN header.) The 802.1p bits, if present in the packet, specify the priority that should be given to packets during forwarding. Packets with a numerically higher (non-zero) priority are given forwarding preference over packets with lower priority bit value.

The IEEE 802.1p standard uses eight levels of priority (0-7). Priority 7 is assigned to highest priority network traffic, such as RIP routing table updates, priorities 5-6 are assigned to delay-sensitive applications such as voice and video, and lower priorities are assigned to standard applications. A value of 0 (zero) indicates a "best effort" traffic prioritization, and this is the default when traffic priority has not been configured on your network. The SI4093 can filter packets based on the 802.1p values, and it can assign or overwrite the 802.1p value in the packet.

Figure 10. Layer 2 802.1q/802.1p VLAN Tagged Packet

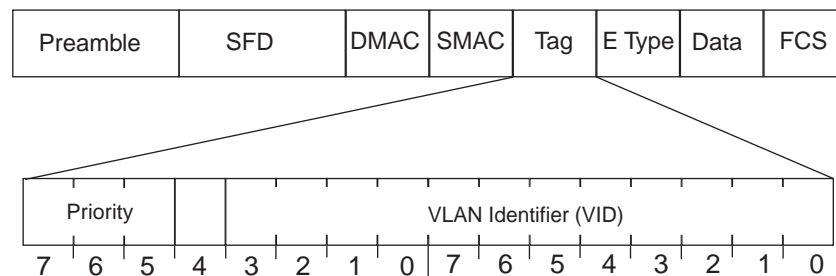

Ingress packets receive a priority value, as follows:

- **Tagged packets**—SI4093 reads the 802.1p priority in the VLAN tag.
- **Untagged packets**—SI4093 tags the packet and assigns an 802.1p priority, based on the port's default priority.

Egress packets are placed in a COS queue based on the priority value, and scheduled for transmission based on the scheduling weight of the COS queue.

To configure a port's default 802.1p priority value, use the following commands.

```
SI 4093(config)# interface port ext1
SI 4093(config-if)# dot1p <802.1p value (0-7)>
SI 4093(config-if)# exit
```

---

## Queuing and Scheduling

The SI4093 can be configured to have either 2 or 8 output Class of Service (COS) queues per port, into which each packet is placed. Each packet's 802.1p priority determines its COS queue, except when an ACL action sets the COS queue of the packet.

You can configure the following attributes for COS queues:

- Map 802.1p priority value to a COS queue
- Define the scheduling weight of each COS queue

You can map 802.1p priority value to a COS queue, as follows:

```
SI 4093(config)# qos transmit-queue mapping <802.1p priority value (0-7)> <COS queue (0-7)>
```

To set the COS queue scheduling weight, use the following command.

```
SI 4093(config)# qos transmit-queue weight-cos <COSq number> <COSq weight (0-15)>
```

The scheduling weight can be set from 0 to 15. Weight values from 1 to 15 set the queue to use weighted round-robin (WRR) scheduling, which distributes larger numbers of packets to queues with the highest weight values. For distribution purposes, each packet is counted the same, regardless of the packet's size.

A scheduling weight of 0 (zero) indicates strict priority. Traffic in strict priority queue has precedence over other all queues. If more than one queue is assigned a weight of 0, the strict queue with highest queue number will be served first. Once all traffic in strict queues is delivered, any remaining bandwidth will be allocated to the WRR queues, divided according to their weight values.

**Note:** Use caution when assigning strict scheduling to queues. Heavy traffic in queues assigned with a weight of 0 can starve lower priority queues.

For a scheduling method that uses a weighted deficit round-robin (WDRR) algorithm, distributing packets with an awareness of packet size, see [“Enhanced Transmission Selection” on page 130](#).

---

## Chapter 13. Basic IP Addresses

This chapter provides configuration background and examples for using the SI4093 10Gb System Interconnect Module (SI4093) to perform BOOTP and DHCP functions.

Dynamic Host Configuration Protocol (DHCP) provides a framework for automatically assigning IP addresses and configuration information to other IP hosts or clients in a large TCP/IP network. Without DHCP, the IP address must be entered manually for each network device. DHCP allows a network administrator to distribute IP addresses from a central point and automatically send a new IP address when a device is connected to a different place in the network.

DHCP is an extension of another network IP management protocol, Bootstrap Protocol (BOOTP), with an additional capability of being able to dynamically allocate reusable network addresses and configuration parameters for client operation.

Built on the client/server model, DHCP allows hosts or clients on an IP network to obtain their configurations from a DHCP server, thereby reducing network administration. The most significant configuration the client receives from the server is its required IP address; (other optional parameters include the “generic” file name to be booted, the address of the default gateway, and so forth).

To enable the DHCP client on the SI4093, use the following command:

```
SI 4093(config)# system dhcp
```





---

## Chapter 14. Internet Protocol Version 6

Internet Protocol version 6 (IPv6) is a network layer protocol intended to expand the network address space. IPv6 is a robust and expandable protocol that meets the need for increased physical address space. The switch supports the following RFCs for IPv6-related features:

- RFC 1981
- RFC 2451
- RFC 2460
- RFC 2461
- RFC 2462
- RFC 2474
- RFC 2526
- RFC 2711
- RFC 3289
- RFC 3306
- RFC 3307
- RFC 3411
- RFC 3412
- RFC 3413
- RFC 3414
- RFC 3484
- RFC 3602
- RFC 3879
- RFC 4007
- RFC 4213
- RFC 4291
- RFC 4293
- RFC 4293
- RFC 4443
- RFC 4861
- RFC 4862
- RFC 5095

This chapter describes the basic configuration of IPv6 addresses and how to manage the switch via IPv6 host management.

---

### IPv6 Limitations

The following IPv6 feature restrictions apply to this release.

- Dynamic Host Control Protocol for IPv6 (DHCPv6) is supported only on the management interface (MGT-port).
- Routing Information Protocol for IPv6 (RIPng) is not supported.

Most other IBM Networking OS 7.7 features permit IP addresses to be configured using either IPv4 or IPv6 address formats. However, the following switch features support IPv4 only:

- Default switch management IP address
- Bootstrap Protocol (BOOTP)
- DHCP for internal management interfaces 127 and 128
- RADIUS, TACACS+ and LDAP
- QoS metering and re-marking ACLs for out-profile traffic
- VMware Virtual Center (vCenter) for VMready
- sFLOW
- TFTP

---

## IPv6 Address Format

The IPv6 address is 128 bits (16 bytes) long and is represented as a sequence of eight 16-bit hex values, separated by colons.

Each IPv6 address has two parts:

- Subnet prefix representing the network to which the interface is connected
- Local identifier, either derived from the MAC address or user-configured

The preferred hexadecimal format is as follows:

```
xxxx:xxxx:xxxx:xxxx:xxxx:xxxx:xxxx:xxxx
```

Example IPv6 address:

```
FEDC:BA98:7654:BA98:FEDC:1234:ABCD:5412
```

Some addresses can contain long sequences of zeros. A single contiguous sequence of zeros can be compressed to :: (two colons). For example, consider the following IPv6 address:

```
FE80:0:0:0:2AA:FF:FA:4CA2
```

The address can be compressed as follows:

```
FE80::2AA:FF:FA:4CA2
```

Unlike IPv4, a subnet mask is not used for IPv6 addresses. IPv6 uses the subnet prefix as the network identifier. The prefix is the part of the address that indicates the bits that have fixed values or are the bits of the subnet prefix. An IPv6 prefix is written in address/prefix-length notation. For example, in the following address, 64 is the network prefix:

```
21DA:D300:0000:2F3C::/64
```

IPv6 addresses can be either user-configured or automatically configured. Automatically configured addresses always have a 64-bit subnet prefix and a 64-bit interface identifier. In most implementations, the interface identifier is derived from the switch's MAC address, using a method called EUI-64.

Most IBM Networking OS 7.7 features permit IP addresses to be configured using either IPv4 or IPv6 address formats. Throughout this manual, *IP address* is used in places where either an IPv4 or IPv6 address is allowed. In places where only one type of address is allowed, the type (*IPv4* or *IPv6* is specified).

---

## IPv6 Address Types

IPv6 supports three types of addresses: unicast (one-to-one), multicast (one-to-many), and anycast (one-to-nearest). Multicast addresses replace the use of broadcast addresses.

### Unicast Address

Unicast is a communication between a single host and a single receiver. Packets sent to a unicast address are delivered to the interface identified by that address. IPv6 defines the following types of unicast address:

- **Global Unicast address:** An address that can be reached and identified globally. Global Unicast addresses use the high-order bit range up to FF00, therefore all non-multicast and non-link-local addresses are considered to be global unicast. A manually configured IPv6 address must be fully specified. Autoconfigured IPv6 addresses are comprised of a prefix combined with the 64-bit EUI. RFC 4291 defines the IPv6 addressing architecture.

The interface ID must be unique within the same subnet.

- **Link-local unicast address:** An address used to communicate with a neighbor on the same link. Link-local addresses use the format FE80::EUI

Link-local addresses are designed to be used for addressing on a single link for purposes such as automatic address configuration, neighbor discovery, or when no routers are present.

Routers must not forward any packets with link-local source or destination addresses to other links.

### Multicast

Multicast is communication between a single host and multiple receivers. Packets are sent to all interfaces identified by that address. An interface may belong to any number of multicast groups.

A multicast address (FF00 - FFFF) is an identifier for a group interface. The multicast address most often encountered is a solicited-node multicast address using prefix FF02::1:FF00:0000/104 with the low-order 24 bits of the unicast or anycast address.

The following well-known multicast addresses are pre-defined. The group IDs defined in this section are defined for explicit scope values, as follows:

FF00:::0 through FF0F:::0

### Anycast

Packets sent to an anycast address or list of addresses are delivered to the nearest interface identified by that address. Anycast is a communication between a single sender and a list of addresses.

Anycast addresses are allocated from the unicast address space, using any of the defined unicast address formats. Thus, anycast addresses are syntactically indistinguishable from unicast addresses. When a unicast address is assigned to more than one interface, thus turning it into an anycast address, the nodes to which the address is assigned must be explicitly configured to know that it is an anycast address.

---

## IPv6 Address Autoconfiguration

IPv6 supports the following types of address autoconfiguration:

- **Stateful address configuration**  
Address configuration is based on the use of a stateful address configuration protocol, such as DHCPv6, to obtain addresses and other configuration options.
- **Stateless address configuration**  
Address configuration is based on the receipt of Router Advertisement messages that contain one or more Prefix Information options.

IBM Networking OS 7.7 supports stateless address configuration.

Stateless address configuration allows hosts on a link to configure themselves with link-local addresses and with addresses derived from prefixes advertised by local routers. Even if no router is present, hosts on the same link can configure themselves with link-local addresses and communicate without manual configuration.

---

## IPv6 Management Interfaces

Management interfaces 125 and 126 support multiple IPv6 addresses. You can manually configure up to two IPv6 addresses for each management interface, or you can allow the switch to use stateless autoconfiguration. By default, the switch automatically configures the IPv6 address of its management interfaces.

You can manually configure two IPv6 addresses for each interface, as follows:

- Initial IPv6 address is a global unicast or anycast address:  

```
interface ip <x>  
address <IPv6 address>
```

Note that you cannot configure both addresses as anycast. If you configure an anycast address on the interface you must also configure a global unicast address on that interface.
- Second IPv6 address can be a unicast or anycast address:  

```
interface ip <x>  
secaddr6 <IPv6 address>
```

You cannot configure an IPv4 address on an IPv6 management interface. Each interface can be configured with only one address type: either IPv4 or IPv6, but not both. When changing between IPv4 and IPv6 address formats, the prior address settings for the interface are discarded.

Each IPv6 interface can belong to only one VLAN. Each VLAN can support only one IPv6 interface. Each VLAN can support multiple IPv4 interfaces.

Interface 125/126 is reserved for IPv6 host support. This interface is included in management VLAN 4095. Use IPv6 gateway mode to configure the IPv6 gateways (`ip gateway6 {<gateway number>} address <IPv6 address>`).

IPv6 gateway 3 and 4 are the default IPv6 management gateways.

---

## Neighbor Discovery

The switch uses Neighbor Discovery protocol (ND) to gather information about other router and host nodes, including the IPv6 addresses. Host nodes use ND to configure their interfaces and perform health detection. ND allows each node to determine the link-layer addresses of neighboring nodes, and to keep track of each neighbor's information. A neighboring node is a host or a router that is linked directly to the switch. The switch supports Neighbor Discovery as described in RFC 4861.

Neighbor Discover messages allow network nodes to exchange information, as follows:

- *Neighbor Solicitations* allow a node to discover information about other nodes.
- *Neighbor Advertisements* are sent in response to Neighbor Solicitations. The Neighbor Advertisement contains information required by nodes to determine the link-layer address of the sender, and the sender's role on the network.
- IPv6 hosts use *Router Solicitations* to discover IPv6 routers. When a router receives a Router Solicitation, it responds immediately to the host.
- Routers uses *Router Advertisements* to announce its presence on the network, and to provide its address prefix to neighbor devices. IPv6 hosts listen for Router Advertisements, and uses the information to build a list of default routers. Each host uses this information to perform autoconfiguration of IPv6 addresses.
- *Redirect messages* are sent by IPv6 routers to inform hosts of a better first-hop address for a specific destination. Redirect messages are only sent by routers for unicast traffic, are only unicast to originating hosts, and are only processed by hosts.

ND configuration for various advertisements, flags, and interval settings is performed on a per-interface basis using the following commands:

```
SI 4093(config)# interface ip <interface number>
SI 4093(config-ip-if)# ipv6 nd <command>
```

Other ND configuration options are available using the following commands:

```
SI 4093(config)# ip neighbors <commands> (Manage static neighbor cache entries)
SI 4093(config)# ipv6 nd ndprefix <prefix> (Define prefix profiles for router advertisements sent from an interface)
```

---

## Supported Applications

The following applications have been enhanced to provide IPv6 support.

- **Ping**

The ping command supports IPv6 addresses. Use the following format to ping an IPv6 address:

```
ping <host name> | <IPv6 address> [-n <tries (0-4294967295)>]
[-w <msec delay (0-4294967295)>] [-l <length (0/32-65500/2080)>]
[-s <IP source>] [-v <TOS (0-255)>] [-f] [-t]
```

To ping a link-local address (begins with FE80), provide an interface index, as follows:

```
ping <IPv6 address>%<Interface index> [-n <tries (0-4294967295)>]
[-w <msec delay (0-4294967295)>] [-l <length (0/32-65500/2080)>]
[-s <IP source>] [-v <TOS (0-255)>] [-f] [-t]
```

- **Traceroute**

The traceroute command supports IPv6 addresses (but not link-local addresses). Use the following format to perform a traceroute to an IPv6 address:

```
traceroute <host name> | <IPv6 address> [<max-hops (1-32)>]
[<msec delay (1-4294967295)>]]
```

- **Telnet**

The telnet command supports IPv6 addresses, but not link-local addresses. Use the following format to Telnet to an IPv6 address:

```
telnet <host name> | <IPv6 address> [<port>]
```

- **SSH**

Secure Shell (SSH) connections over IPv6 are supported, but not link-local addresses. The following syntax is required from the client:

```
ssh -u <IPv6 address>
```

Example:

```
ssh -u 2001:2:3:4:0:0:0:142
```

- **TFTP**

The TFTP commands support both IPv4 and IPv6 addresses. Link-local addresses are not supported.

- **FTP**

The FTP commands support both IPv4 and IPv6 addresses. Link-local addresses are not supported.

- **DNS client**

DNS commands support both IPv4 and IPv6 addresses. Link-local addresses are not supported. Use the following command to specify the type of DNS query to be sent first:

```
SI 4093(config)# ip dns ipv6 request-version {ipv4|ipv6}
```

If you set the request version to `v4`, the DNS application sends an `A` query first, to resolve the hostname with an IPv4 address. If no `A` record is found for that hostname (no IPv4 address for that hostname) an `AAAA` query is sent to resolve the hostname with a IPv6 address.

If you set the request version to `v6`, the DNS application sends an `AAAA` query first, to resolve the hostname with an IPv6 address. If no `AAAA` record is found for that hostname (no IPv6 address for that hostname) an `A` query is sent to resolve the hostname with an IPv4 address.

---

## Configuration Guidelines

When you configure an interface for IPv6, consider the following guidelines:

- Support for subnet router anycast addresses is not available.
- Interfaces 125 and 126 are reserved for IPv6 management.
- A single interface can accept either IPv4 or IPv6 addresses, but not both IPv4 and IPv6 addresses.
- A single interface can accept multiple IPv6 addresses.
- A single interface can accept only one IPv4 address.
- If you change the IPv6 address of a configured interface to an IPv4 address, all IPv6 settings are deleted.
- Health checks are not supported for IPv6 gateways.
- IPv6 interfaces support Path MTU Discovery. The CPU's MTU is fixed at 1500 bytes.
- Support for jumbo frames (1,500 to 9,216 byte MTUs) is limited. Any jumbo frames intended for the CPU must be fragmented by the remote node. The switch can re-assemble fragmented packets up to 9k. It can also fragment and transmit jumbo packets received from higher layers.

---

## IPv6 Configuration Examples

This section provides steps to configure IPv6 on the switch.

### IPv6 Example 1

The following example uses IPv6 host mode to autoconfigure an IPv6 address for the management interface.

1. Enable IPv6 host mode on an interface.

```
SI 4093(config)# interface ip 125           (Select IP interface 125)
SI 4093(config-ip-if)# ip6host             (Enable IPv6 host mode)
SI 4093(config-ip-if)# enable              (Enable the IP interface)
```

2. Configure (select and enable) the IPv6 default gateway.

```
SI 4093(config)# ip gateway6 3 address 2001:BA98:7654:BA98:FEDC:1234:ABCD:5412
enable
```

3. Verify the interface address.

```
SI 4093(config)# show interface ip 125     (Display interface information)
```



## IPv6 Example 2

Use the following example to manually configure IPv6 on an interface.

1. Assign an IPv6 address and prefix length to the interface.

```
SI 4093(config)# interface ip 125
SI 4093(config-ip-if)# ipv6 address 2001:BA98:7654:BA98:FEDC:1234:ABCD:5214 32
ena
SI 4093(config-ip-if)# ipv6 prefixlen 64
SI 4093(config-ip-if)# ipv6 secaddr6 address 2003::1 32
```

The secondary IPv6 address is compressed, and the prefix length is 32.

2. Configure the IPv6 default gateway.

```
SI 4093(config)# ip gateway6 3 address 2001:BA98:7654:BA98:FEDC:1234:ABCD:5412
ena                                     (Enable default gateway)
```

3. Configure Router advertisements for the interface (optional)

```
SI 4093(config-ip-if)# ipv6 nd advmtu   (Enable Router Advertisements)
```

4. Verify the configuration.

```
SI 4093# show ipv6 interface           (View current IP settings)
SI 4093# show ipv6 gateway6 3         (View current IP gateway 3 settings)
```



# Chapter 15. Fibre Channel over Ethernet

## FCoE Overview

Fibre Channel over Ethernet (FCoE) is an effort to converge two of the different physical networks in today's data centers. It allows Fibre Channel traffic (such as that commonly used in Storage Area Networks, or SANs) to be transported without loss over 10Gb Ethernet links (typically used for high-speed Local Area Networks, or LANs). This provides an evolutionary approach toward network consolidation, allowing Fibre Channel equipment and tools to be retained, while leveraging cheap, ubiquitous Ethernet networks for growth.

With server virtualization, servers capable of hosting both Fibre Channel and Ethernet applications will provide advantages in server efficiency, particularly as FCoE-enabled network adapters provide consolidated SAN and LAN traffic capabilities.

The IBM Flex System Fabric SI4093 System Interconnect Module with IBM Networking OS 7.7 software is compliant with the INCITS T11.3, FC-BB-5 FCoE specification.

**Note:** On the SI4093, CEE features for transparent (non-FIP snooping) FCoE are turned on by default. If you are not using FCoE, it is recommended that you turn off CEE. See [“Turning CEE On or Off” on page 118](#).

## The FCoE Topology

In an end-to-end Fibre Channel network, switches and end devices generally establish trusted, point-to-point links. Fibre Channel switches validate end devices, enforce zoning configurations and device addressing, and prevent certain types of errors and attacks on the network.

In a converged multi-hop FCoE network where Fibre Channel devices are bridged to Ethernet devices, the direct point-to-point assurances normally provided by the Fibre Channel fabric may be lost in the transition between the different network types. However, the SI4093 provides a solution for this problem.

Figure 11. A Mixed Fibre Channel and FCoE Network

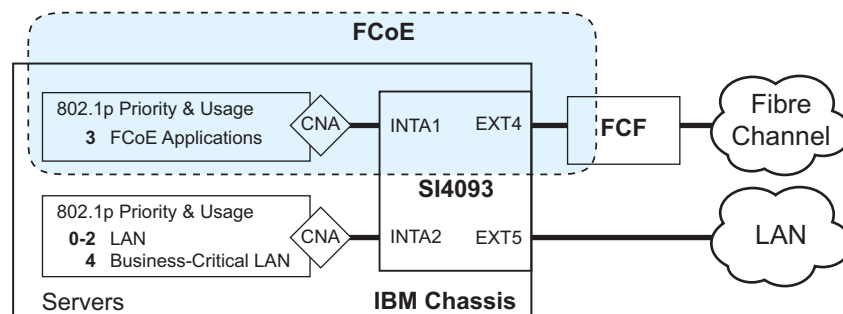

In [Figure 11 on page 115](#), the Fibre Channel network is connected to the FCoE network through an Fibre Channel Forwarder (FCF) bridge. The FCF acts as a Fibre Channel gateway to and from the multi-hop FCoE network.

For the FCoE portion of the network, the FCF is connected to the FCoE-enabled SI4093, which is internally connected to a blade server (running Fibre Channel applications) through an FCoE-enabled Converged Network Adapter (CNA) known in Fibre Channel as an Ethernet Node (ENode).

**Note:** The figure also shows a non-FCoE LAN server connected to the SI4093 using a CNA. This allows the LAN server to take advantage of some CEE features that are useful even outside of an FCoE environment.

## FCoE Security

On the SI4093, FCoE security behaves differently depending on whether a transparent SPAR or a VLAN-aware SPAR is used.

### FIP-Aware FCoE

The SI4093 can block undesired or unvalidated traffic on FCoE links that exists outside the regular Fibre Channel topology, Ethernet ports used in FCoE on VLAN-aware SPARs are configured with Access Control Lists (ACLs) that are narrowly tailored to permit expected FCoE traffic to and from confirmed FCFs and ENodes, and deny all other FCoE or FCoE Initialization Protocol (FIP) traffic. This ensures that all FCoE traffic to and from the ENode passes through the FCF.

Because manual ACL configuration is an administratively complex task, the SI4093 can automatically and dynamically configure the ACLs required for use with FCoE on VLAN-aware SPARs. Using FIP snooping (see [“FCoE Initialization Protocol Snooping” on page 121](#)), the SI4093 examines the FIP frames normally exchanged between the FCF and ENodes to determine information about connected FCoE devices. This information is used to automatically determine the appropriate ACLs required to block certain types of undesired or unvalidated FCoE traffic.

Automatic FCoE-related ACLs are independent from ACLs used for typical Ethernet purposes.

FIP snooping is globally turned off by default. When the feature is turned on, FIP snooping is can be enabled or disabled on port by port basis. By default, FIP snooping is enabled on all ports.

### Transparent FCoE

When FIP snooping is disabled, FCoE security must be fully enforced by the attached servers and upstream devices. For ports where FIP snooping is disabled, the SI4093 does not validate FCoE traffic or automatically install FCoE-related ACLs.

Transparent FCoE is available in transparent SPARs and VLAN-aware SPARs.

## FCoE Requirements

The following are required for implementing FCoE using the SI4093 with Networking OS 7.7 software:

- The SI4093 must be connected to the Fibre Channel network through an FCF such as an IBM RackSwitch G8264CS or a Cisco Nexus 5000 Series Switch.
- For each SI4093 internal port participating in FCoE, the connected blade server must use the supported FCoE CNA. Emulex Virtual Fabric Adapter 2-port 10Gb LOM and Emulex Virtual Fabric Adapter (Fabric Mezz) for IBM Flex System, which includes vNIC support (with some additional topology rules), is currently supported.
- For each SI4093 internal port participating in FCoE, the connected blade server must include the appropriate FCoE licenses installed, as obtained using the IBM website Features on Demand (FoD) service. Contact your sales representative for more information on obtaining server feature licenses.
- CEE must be turned on (see [“Turning CEE On or Off” on page 118](#)). When CEE is on, the DCBX, PFC, and ETS features are enabled and configured with default FCoE settings. These features may be reconfigured, but must remain enabled in order for FCoE to function.
- FIP snooping is not supported in transparent SPARs. If using a transparent SPAR for FCoE, FIP snooping is ignored, and FCoE security must be enforced by the attached servers and upstream devices.
- If FIP snooping is desired on a SPAR, the SPAR must be configured for VLAN-aware mode and FIP snooping must be turned on for the SPAR (see [“FCoE Initialization Protocol Snooping” on page 121](#)). When FIP snooping is turned on, the feature is enabled on all ports in the SPAR by default. The administrator can disable FIP snooping on individual ports that do not require FCoE, but FIP snooping must remain enabled on all FCoE ports in order to support secured FCoE sessions in VLAN-aware SPARs.

## Port Trunking

IBM Networking OS 7.7 supports port trunking for FCoE connections. The Link Aggregation (LAG) can be used for separate FCoE traffic, or for Ethernet and FCoE traffic. Ports directly connected to servers cannot be combined in a LAG group.

Uplink ports, connected to the FCF, can be grouped as static or dynamic trunks.

Internal ports cannot be grouped as trunks.

Normal trunk operations such as creating/enabling the trunk, and adding/removing member ports can be performed. When a port is added to a trunk group, FCFs previously detected on the port will be deleted. The deleted FCF may be relearned later. However, this may cause flickering in the network traffic.

Priority-based Flow Control (PFC), and Data Center Bridging (DCBX) are configured on a per-port basis. Each port in a trunk must have the same PFC, and DCBX configuration. When a port ceases to be the trunk group member, its configuration does not change.

---

## Converged Enhanced Ethernet

Converged Enhanced Ethernet (CEE) refers to a set of IEEE standards designed to allow different physical networks with different data handling requirements to be converged together, simplifying management, increasing efficiency and utilization, and leveraging legacy investments without sacrificing evolutionary growth.

CEE standards were developed primarily to enable Fibre Channel traffic to be carried over Ethernet networks. This required enhancing the existing Ethernet standards to make them lossless on a per-priority traffic basis, and to provide a mechanism to carry converged (LAN/SAN/IPC) traffic on a single physical link. Although CEE standards were designed with FCoE in mind, they are not limited to FCoE installations. CEE features can be utilized in traditional LAN (non-FCoE) networks to provide lossless guarantees on a per-priority basis, and to provide efficient bandwidth allocation based on application needs.

### Turning CEE On or Off

**Note:** By default on the SI4093, CEE is turned on. If you are not using FCoE, it is recommended that you turn off CEE.

To turn CEE on or off, use the following command:

```
SI 4093(config)# [no] cee enable
```

For an example, see [“FIP Snooping Configuration” on page 125](#).



**CAUTION:**

Turning CEE on and applying the configuration will automatically change some 802.1p QoS and 802.3x standard flow control settings on the SI4093. Read the following material carefully to determine whether you will need to take action to reconfigure expected settings.

It is recommended that you backup your configuration prior to turning CEE on. Viewing the file will allow you to manually re-create the equivalent configuration once CEE is turned on, and will also allow you to recover your prior configuration if you need to turn CEE off.

### Effects on Link Layer Discovery Protocol

When CEE is turned on, Link Layer Discovery Protocol (LLDP) is automatically turned on and enabled for receiving and transmitting DCBX information. LLDP cannot be turned off while CEE is turned on.

## Effects on 802.1p Quality of Service

When CEE is off, the S14093 allows 802.1p priority values to be used for Quality of Service (QoS) configuration (see the *Application Guide*). 802.1p QoS default settings are shown in [Table 13 on page 119](#), but can be changed by the administrator.

While CEE is turned on (the default), 802.1p QoS is replaced by ETS (see [“Enhanced Transmission Selection” on page 130](#)). As a result, while CEE is turned on, the 802.1p QoS configuration commands are no longer available on the S14093 (the commands are restored when CEE is turned off).

In addition, while CEE is turned on, any prior 802.1p QoS settings are replaced with new defaults designed for use with ETS priority groups (PGIDs) as shown in [Table 13](#):

Table 13. CEE Effects on 802.1p Defaults

802.1p QoS Configuration With CEE Off			ETS Configuration With CEE On		
Priority	COSq	Weight	Priority	COSq	PGID
0	0	1	0	0	0
1	1	2	1	0	0
2	2	3	2	0	0
3	3	4	3	1	1
4	4	5	4	2	2
5	5	7	5	2	2
6	6	15	6	2	2
7	7	0	7	2	2

When CEE is on, the default ETS configuration also allocates a portion of link bandwidth to each PGID as shown in [Table 14](#):

Table 14. Default ETS Bandwidth Allocation

PGID	Typical Use	Bandwidth
0	LAN	10%
1	SAN	50%
2	Latency-sensitive LAN	40%

If the prior, non-CEE configuration used 802.1p priority values for different purposes, or does not expect bandwidth allocation as shown in [Table 14 on page 119](#), when CEE is turned on, the administrator should reconfigure ETS settings as appropriate.

## Effects on Flow Control

When CEE is off, 802.3x standard flow control is enabled on all SI4093 ports by default.

When CEE is turned on, standard flow control is disabled on all ports, and in its place, PFC (see [“Priority-Based Flow Control” on page 126](#)) is enabled on all ports for 802.1p priority value 3. This default is chosen because priority value 3 is commonly used to identify FCoE traffic in a CEE environment and must be guaranteed lossless behavior. PFC is disabled for all other priority values.

Each time CEE is turned off, the prior 802.3x standard flow control settings will be restored (including any previous changes from the defaults). Conversely, each time CEE is turned on, the previously configured PFC settings are restored.

It is recommend that a configuration backup be made prior to turning CEE on or off. Viewing the configuration file will allow the administrator to manually re-create the equivalent configuration under the new CEE mode, and will also allow for the recovery of the prior configuration if necessary.

When CEE is on, PFC can be enabled only on priority value 3 and one other priority. If flow control is required on additional priorities on any given port, consider using standard flow control on that port, so that regardless of which priority traffic becomes congested, a flow control frame is generated.



---

## FCoE Initialization Protocol Snooping

FCoE Initialization Protocol (FIP) snooping is an FCoE feature. In order to enforce point-to-point links for FCoE traffic outside the regular Fibre Channel topology, Ethernet ports used in FCoE can be automatically and dynamically configured with Access Control Lists (ACLs).

Using FIP snooping, the SI4093 examines the FIP frames normally exchanged between the FCF and ENodes to determine information about connected FCoE devices. This information is used to create narrowly tailored ACLs that permit expected FCoE traffic to and from confirmed Fibre Channel nodes, and deny all other undesirable FCoE or FIP traffic.

In case of trunk groups, FIP traffic from a particular FCF can be received by any member port on which the FCF was detected.

**Note:** FIP snooping is not supported on transparent SPARs.

### Global FIP Snooping Settings

By default, the FIP snooping feature is turned off for the SI4093. The following commands are used to turn the feature on or off:

```
SI 4093(config)# [no] fcoe fips enable
```

**Note:** FIP snooping requires CEE to be turned on (see [“Turning CEE On or Off” on page 118](#)).

When FIP snooping is on, port participation may be configured on a port-by-port basis (see [“FIP Snooping for Specific Ports” on page 122](#)).

Before turning on the FIP snooping feature, you must manually disable FIP snooping for internal and external ports where *any* of the following conditions apply:

- Disable for all transparent SPAR ports.
- Disable for ports where FCoE traffic is not desired.
- Disable for ports where transparent FCoE is acceptable.

When FIP snooping is off, all FCoE-related ACLs generated by the feature are removed from all SI4093 ports.

FIP snooping configuration must be the same on all member ports in a trunk group. If the configuration of a member port is changed, an error message, similar to the following, will be displayed.

```
FAIL: Trunk <ID> FIP Snooping port <number> and port <number> need to have the same fips config.
```

The FIP snooping configuration changes must be manually applied to all member ports.

For an example, see [“FIP Snooping Configuration” on page 125](#).

## FIP Snooping for Specific Ports

When FIP snooping is globally turned on (see above), ports may be individually configured for participation in FIP snooping and automatic ACL generation. By default, FIP snooping is enabled for each port. To change the setting for any specific port, use the following CLI commands:

```
SI 4093(config)# [no] fcoe fips port <port alias or number> enable
```

When FIP snooping is enabled on a port, FCoE-related ACLs will be automatically configured.

When FIP snooping is disabled on a port, all FCoE-related ACLs on the port are removed, and the SI4093 will enforce no FCoE-related rules for traffic on the port.

Before turning on the FIP snooping feature, you must manually disabled FIP snooping for internal and external ports where *any* of the following conditions apply:

- Disable for all transparent SPAR ports.
- Disable for ports where FCoE traffic is not desired.
- Disable for ports where transparent FCoE is acceptable.

**Note:** FIP Snooping and IPv6 ACLs are not supported simultaneously on the same ports. To use FIP snooping, remove IPv6 ACLs from the port.

## Port FCF and ENode Detection

When FIP snooping is enabled on a port in a VLAN-aware SPAR, the port is placed in FCF auto-detect mode by default. In this mode, the port assumes connection to an ENode unless FIP packets show the port is connected to an FCF.

Ports can also be specifically configured as to whether automatic FCF detection should be used, or whether the port is connected to an FCF or ENode:

```
SI 4093(config)# fcoe fips port <port alias or number> fcf-mode [auto|on|off]
```

When FCF mode is `on`, the port is assumed to be connected to a trusted FCF, and only ACLs appropriate to FCFs will be installed on the port. When `off`, the port is assumed to be connected to an ENode, and only ACLs appropriate to ENodes will be installed. When the mode is changed (either through manual configuration or as a result of automatic detection), the appropriate ACLs are automatically added, removed, or changed to reflect the new FCF or ENode connection.

## FCoE Connection Timeout

FCoE-related ACLs are added, changed, and removed as FCoE device connection and disconnection are discovered. In addition, the administrator can enable or disable automatic removal of ACLs for FCFs and other FCoE connections that timeout (fail or are disconnected) without FIP notification.

By default, automatic removal of ACLs upon timeout is enabled. To change this function, use the following CLI commands:

```
SI 4093(config)# [no] fcoe fips timeout-acl
```

## FCoE ACL Rules

When FIP Snooping is enabled on a port, the SI4093 automatically installs the appropriate ACLs to enforce the following rules for FCoE traffic:

- Ensure that FIP frames from ENodes may only be addressed to FCFs.
- Flag important FIP packets for processing.
- Ensure no end device uses an FCF MAC address as its source.
- Each FCoE port is assumed to be connected to an ENode and includes ENode-specific ACLs installed, until the port is either detected or configured to be connected to an FCF.
- Ports that are configured to have FIP snooping disabled will not have any FIP or FCoE related ACLs installed.
- Prevent transmission of all FCoE frames from an ENode prior to its successful completion of login (FLOGI) to the FCF.
- After successful completion of FLOGI, ensure that the ENode uses only those FCoE source addresses assigned to it by FCF.
- After successful completion of FLOGI, ensure that all ENode FCoE source addresses originate from or are destined to the appropriate ENode port.
- After successful completion of each FLOGI, ensure that FCoE frames may only be addressed to the FCFs that accept them.

Initially, a basic set of FCoE-related ACLs will be installed on all ports where FIP snooping is enabled. As the SI4093 encounters FIP frames and learns about FCFs and ENodes that are attached or disconnect, ACLs are dynamically installed or expanded to provide appropriate security.

When an FCoE connection logs out, or times out (if ACL timeout is enabled), the related ACLs will be automatically removed.

FCoE-related ACLs are independent of manually configured ACLs used for regular Ethernet purposes (see the *Application Guide*). FCoE ACLs generally have a higher priority over standard ACLs.

## FCoE VLANs

Before the SI4093 applies FIP Snooping, all internal SI4093 ports connected to ENodes and all external ports connected to FCFs should be members of at least one common VLAN (for example, the SPAR default VLAN). This allows the ENode CNA and the FCF to exchange initial FIP VLAN request and notification packets. Once FIP Snooping is applied, FCoE packets are exchanged using one configured FCoE VLAN for each attached FCF.

Each ENode port must retain the VLAN tag, and must belong to the same VLAN as the FCF to which it will connect. In topologies where a single FCF is connected to the SI4093, all ENode and FCF ports belong to the same VLAN (typically VLAN 1002). When multiple FCFs are connected to the SI4093, each FCF must be assigned a unique VLAN, and each ENode must be assigned to the VLAN for only one particular FCF.

The administrator must ensure that the VLAN configured for each FCF and its ENodes is supported by the participating FCF and ENode CNAs.

## Viewing FIP Snooping Information

ACLs automatically generated under FIP snooping are independent of regular, manually configure ACLs, and are not listed with regular ACLs in SI4093 information and statistics output. Instead, FCoE ACLs are shown using the following CLI commands:

```
SI 4093# show fcoe fips information           (Show all FIP-related information)
SI 4093# show fcoe fips port <port alias or number> information
                                                (Show FIP info for a selected port)
```

For example:

```
SI 4093# show fcoe fips port ext4 information

FIP Snooping on port ext4:
This port has been detected to be an FCF port.

FIPS ACLs configured on this port:
Ethertype 0x8914, action permit.
dmac 00:00:18:01:00:XX, Ethertype 0x8914, action permit.
```

For each ACL, the required traffic criteria are listed, along with the action taken (permit or deny) for matching traffic. ACLs are listed in order of precedence and evaluated in the order shown.

The administrator can also view other FCoE information:

```
SI 4093# show fcoe fips fcf                 (Show all detected FCFs)
SI 4093# show fcoe fips fcoe                (Show all FCoE connections)
```

## FIP Snooping Configuration

In this example, FCoE devices are connected to port EXT4 for the FCF bridge connection, and INTA1 for an ENode. FIP snooping can be configured on these ports using the following CLI commands:

1. Disable FIP snooping on all non-FCoE external ports:

```
SI 4093(config)# no fcoe fips port ext1-ext3,ext5-ext10 enable
```

1. (Set by default) Turn global FIP snooping on:

```
SI 4093(config)# fcoe fips enable
```

2. Make sure CEE is turned on (the default setting). If CEE has been previously turned off, turn it on using the following command:

```
SI 4093(config)# cee enable
```

**Note:** Turning CEE on or off will automatically change some 802.1p QoS and 802.3x standard flow control settings and menus (see ["Turning CEE On or Off" on page 118](#)).

3. Configure a VLAN-aware SPAR for use with FCoE:

```
SI 4093(config)# spar 2
SI 4093(config-spar)# uplink port ext4
SI 4093(config-spar)# domain mode local
SI 4093(config-spar)# domain default vlan 4082
SI 4093(config-spar)# domain default member inta1
```

4. Add the FCoE VLAN to the SPAR, with all FCoE member internal ports:

```
SI 4093(config-spar)# domain local 1 vlan 1002
SI 4093(config-spar)# domain local 1 member inta1
SI 4093(config-spar)# domain local 1 name vid1002
SI 4093(config-spar)# domain local 1 enable
```

5. Enable the SPAR and exit SPAR configuration:

```
SI 4093(config-spar)# enable
SI 4093(config-spar)# exit
```

6. (Set by default) Enable FIP snooping on FCoE ports, and set the desired FCF mode:

```
SI 4093(config)# fcoe fips port INTA1 ena
                                                    (Select ENode port and enable FIP
                                                    snooping)
SI 4093(config)# fcoe fips port INTA1 fcf-mode off
                                                    (Set as ENode connection)
SI 4093(config)# fcoe fips port ext4 ena
                                                    (Enable FIP snooping on port)
SI 4093(config)# fcoe fips port ext4 fcf-mode on
                                                    (Set as FCF connection)
```

---

## Priority-Based Flow Control

Priority-based Flow Control (PFC) is defined in IEEE 802.1Qbb. PFC extends the IEEE 802.3x standard flow control mechanism. Under standard flow control, when a port becomes busy, the SI4093 manages congestion by pausing all the traffic on the port, regardless of the traffic type. PFC provides more granular flow control, allowing the SI4093 to pause specified types of traffic on the port, while other traffic on the port continues.

PFC pauses traffic based on 802.1p priority values in the VLAN tag. The administrator can assign different priority values to different types of traffic and then enable PFC for up to two specific priority values: priority value 3, and one other. The configuration can be applied on a port-by-port basis, or globally for all ports on the SI4093. Then, when traffic congestion occurs on a port (caused when ingress traffic exceeds internal buffer thresholds), only traffic with priority values where PFC is enabled is paused. Traffic with priority values where PFC is disabled proceeds without interruption but may be subject to loss if port ingress buffers become full.

Although PFC is useful for a variety of applications, it is required for FCoE implementation where storage (SAN) and networking (LAN) traffic are converged on the same Ethernet links. Typical LAN traffic tolerates Ethernet packet loss that can occur from congestion or other factors, but SAN traffic must be lossless and requires flow control.

For FCoE, standard flow control would pause both SAN and LAN traffic during congestion. While this approach would limit SAN traffic loss, it could degrade the performance of some LAN applications that expect to handle congestion by dropping traffic. PFC resolves these FCoE flow control issues. Different types of SAN and LAN traffic can be assigned different IEEE 802.1p priority values. PFC can then be enabled for priority values that represent SAN and LAN traffic that must be paused during congestion, and disabled for priority values that represent LAN traffic that is more loss-tolerant.

PFC requires CEE to be turned on ([“Turning CEE On or Off” on page 118](#)). When CEE is turned on, PFC is enabled on priority value 3 by default. Optionally, the administrator can also enable PFC on one other priority value, providing lossless handling for another traffic type, such as for a business-critical LAN application.

**Note:** For any given port, only one flow control method can be implemented at any given time: either PFC or standard IEEE 802.3x flow control.

## Global vs. Port-by-Port PFC Configuration

PFC requires CEE to be turned on ([“Turning CEE On or Off” on page 118](#)). When CEE is turned on, standard flow control is disabled on all ports, and PFC is enabled on all ports for 802.1p priority value 3. This default is chosen because priority value 3 is commonly used to identify FCoE traffic in a CEE environment and must be guaranteed lossless behavior. PFC is disabled for all other priority values by default, but can be enabled for one additional priority value.

The administrator can also configure PFC on a port-by-port basis. The method used will typically depend on the following:

- Port-by-port PFC configuration is desirable in most mixed environments where some SI4093 ports are connected to CEE-capable (FCoE) switches, gateways, and Converged Network Adapters (CNAs), and other SI4093 ports are connected to non-CEE Layer 2/Layer 3 switches, routers and Network Interface Cards (NICs).
- Global PFC configuration is preferable in networks that implement end-to-end CEE devices. For example, if all ports are involved with FCoE and can use the same SAN and LAN priority value configuration with the same PFC settings, global configuration is easy and efficient.
- Global PFC configuration can also be used in some mixed environments where traffic with PFC-enabled priority values occurs only on ports connected to CEE devices, and not on any ports connected to non-CEE devices. In such cases, PFC can be configured globally on specific priority values even though not all ports make use them.
- PFC is not restricted to CEE and FCoE networks. In any LAN where traffic is separated into different priorities, PFC can be enabled on priority values for loss-sensitive traffic. If all ports have the same priority definitions and utilize the same PFC strategy, PFC can be globally configured.

**Note:** When using global PFC configuration in conjunction with the ETS feature (see [“Enhanced Transmission Selection” on page 130](#)), ensure that only pause-tolerant traffic (such as lossless FCoE traffic) is assigned priority values where PFC is enabled. Pausing other types of traffic can have adverse effects on LAN applications that expect uninterrupted traffic flow and tolerate dropping packets during congestion. Use PFC globally only if all priority values assigned for lossless traffic on one or more ports does not carry loss-tolerant traffic on other ports.

## PFC Configuration Example

**Note:** DCBX may be configured to permit sharing or learning PFC configuration with or from external devices. This example assumes that PFC configuration is being performed manually. See [“Data Center Bridging Capability Exchange” on page 136](#) for more information on DCBX.

This example is consistent with the network shown in [Figure on page 116](#). In this example, the following topology is used.

Table 15. Port-Based PFC Configuration

SI4093 Port	802.1p Priority	Usage	PFC Setting
EXT5	0-2	LAN	Disabled
	3	(not used)	<b>Enabled</b>
	4	Business-critical LAN	<b>Enabled</b>
	others	(not used)	Disabled
EXT4	3	FCoE (to FCF bridge)	<b>Enabled</b>
	others	(not used)	Disabled
INTA1	3	FCoE	<b>Enabled</b>
	others	(not used)	Disabled
INTA2	0-2	LAN	Disabled
	3	(not used)	<b>Enabled</b>
	4	Business-critical LAN	<b>Enabled</b>
	others	(not used)	Disabled

In this example, PFC is to facilitate lossless traffic handling for FCoE (priority value 3) and a business-critical LAN application (priority value 4).



Assuming that CEE is off (the SI4093 default), the example topology shown in [Table 15 on page 128](#) can be configured using the following commands:

1. Turn CEE on.

```
SI 4093(config)# cee enable
```

2. Enable PFC for the FCoE traffic.

**Note:** PFC is enabled on priority 3 by default. If using the defaults, the manual configuration commands shown in this step are not necessary.

```
SI 4093(config)# cee port INTA1 pfc          (Turn on PFC for port) INTA1)
SI 4093(config)# cee port INTA1 pfc priority 3 enable
                                                (Select and enable FCoE priority 3 PFC for the port)
SI 4093(config)# cee port INTA1 pfc priority 3 description "FCoE"
                                                (Set priority description—optional)
SI 4093(config)# cee port EXT4 pfc          (Select and enable FCoE for port EXT4)
SI 4093(config)# cee port EXT4 pfc priority 3 enable
                                                (Select and enable FCoE priority 3 PFC for the port)
SI 4093(config)# cee port EXT4 pfc priority 3 description "FCoE"
                                                (Set priority description—optional)
```

3. Enable PFC for the business-critical LAN application:

```
SI 4093(config)# cee port INTA2 pfc          (Turn on PFC for port) INTA2)
SI 4093(config)# cee port INTA2 pfc priority 4 enable
                                                (Select and enable FCoE priority 4 PFC for the port)
SI 4093(config)# cee port INTA2 pfc priority 4 description "Business-critical
LAN"
                                                (Set priority description—optional)
SI 4093(config)# cee port EXT5 pfc          (Select and enable FCoE for port EXT5)
SI 4093(config)# cee port EXT5 pfc priority 4 enable
                                                (Select and enable FCoE priority 4 PFC for the port)
SI 4093(config)# cee port EXT5 pfc priority 4 description "Business-critical
LAN"
                                                (Set priority description—optional)
```

4. Save the configuration.

```
SI 4093(config)# copy running-config startup-config
```



In the assignment model shown in [Figure 12 on page 130](#), priorities values 0 through 2 are assigned for regular Ethernet traffic, which has “best effort” transport characteristics.

Priority 3 is typically used to identify FCoE (SAN) traffic.

Priorities 4-7 are typically used for latency sensitive traffic and other important business applications. For example, priority 4 and 5 are often used for video and voice applications such as IPTV, Video on Demand (VoD), and Voice over IP (VoIP). Priority 6 and 7 are often used for traffic characterized with a “must get there” requirement, with priority 7 used for network control which requires guaranteed delivery to support configuration and maintenance of the network infrastructure.

**Note:** The default assignment of 802.1p priority values on the SI4093 changes depending on whether CEE is on or off. See [“Turning CEE On or Off” on page 118](#) for details.

## Priority Groups

For ETS use, each 801.2p priority value is assigned to a priority group which can then be allocated a specific portion of available link bandwidth. To configure a priority group, the following is required:

- CEE must be turned on ([“Turning CEE On or Off” on page 118](#)) for the ETS feature to function.
- A priority group must be assigned a priority group ID (PGID), one or more 802.1p priority values, and allocated link bandwidth greater than 0%.

## PGID

Each priority group is identified with number (0 through 7, and 15) known as the PGID.

PGID 0 through 7 may each be assigned a portion of the available bandwidth.

PGID 8 through 14 are reserved as per the 802.1Qaz ETS standard.

PGID 15 is a strict priority group. It is generally used for critical traffic, such as network management. Any traffic with priority values assigned to PGID 15 is permitted as much bandwidth as required, up to the maximum available on the SI4093. After serving PGID 15, any remaining link bandwidth is shared among the other groups, divided according to the configured bandwidth allocation settings.

All 802.1p priority values assigned to a particular PGID should have similar traffic handling requirements. For example, PFC-enabled traffic should not be grouped with non-PFC traffic. Also, traffic of the same general type should be assigned to the same PGID. Splitting one type of traffic into multiple 802.1p priorities, and then assigning those priorities to different PGIDs may result in unexpected network behavior.

Each 802.1p priority value may be assigned to only one PGID. However, each PGID may include multiple priority values. Up to eight PGIDs may be configured at any given time.

## Assigning Priority Values to a Priority Group

Each priority group may be configured from its corresponding ETS Priority Group and assigned 802.1p priority values using the following command:

```
SI 4093(config)# cee global ets priority-group pgid <priority group number (0-7, or 15)> prio  
<priority list>
```

where *priority list* is one or more 802.1p priority values (with each separated by a space). For example, to assign priority values 0 through 2 to PGID 0:

```
SI 4093(config)# cee global ets priority-group pgid 0 prio 0 1 2
```

**Note:** Within any specific PGID, the PFC settings (see [“Priority-Based Flow Control” on page 126](#)) should be the same (enabled or disabled) for all priority values within the group. PFC can be enabled only on priority value 3 and one other priority. If the PFC setting is inconsistent within a PGID, a warning message is reported when attempting to apply the configuration.

When assigning priority values to a PGID, the specified priority value will be automatically removed from its old group and assigned to the new group when the configuration is applied.

Each priority value must be assigned to a PGID. Priority values may not be deleted or unassigned. To remove a priority value from a PGID, it must be moved to another PGID.

For PGIDs 0 through 7, bandwidth allocation can also be configured through the ETS Priority Group menu. See for [“Allocating Bandwidth” on page 133](#) for details.

## Deleting a Priority Group

A priority group is automatically deleted when it contains no associated priority values, and its bandwidth allocation is set to 0%.

**Note:** The total bandwidth allocated to PGID 0 through 7 must equal exactly 100%. Reducing the bandwidth allocation of any group will require increasing the allocation to one or more of the other groups (see [“Allocating Bandwidth” on page 133](#)).

## Allocating Bandwidth

### Allocated Bandwidth for PGID 0 Through 7

The administrator may allocate a portion of the available bandwidth to PGIDs 0 through 7. Available bandwidth is defined as the amount of link bandwidth that remains after priorities within PGID 15 are serviced (see [“Unlimited Bandwidth for PGID 15” on page 133](#)), and assuming that all PGIDs are fully subscribed. If any PGID does not fully consume its allocated bandwidth, the unused portion is made available to the other priority groups.

Priority group bandwidth allocation can be configured using the following command:

```
SI 4093(config)# cee global ets priority-group pgid <priority group number> bandwidth  
<bandwidth allocation (0-100)>
```

where *bandwidth allocation* represents the percentage of link bandwidth, specified as a number between 0 and 100, in 1% increments.

The following bandwidth allocation rules apply:

- Bandwidth allocation must be 0% for any PGID that has no assigned 802.1p priority values.
- Any PGID assigned one or more priority values must have a bandwidth allocation greater than 0%.
- Total bandwidth allocation for groups 0 through 7 must equal exactly 100%. Increasing or reducing the bandwidth allocation of any PGID also requires adjusting the allocation of other PGIDs to compensate.

If these conditions are not met, the SI4093 will report an error when applying the configuration.

To achieve a balanced bandwidth allocation among the various priority groups, packets are scheduled according to a weighted deficit round-robin (WDRR) algorithm. WDRR is aware of packet sizes, which can vary significantly in a CEE environment, making WDRR more suitable than a regular weighted round-robin (WRR) method, which selects groups based only on packet counts.

**Note:** Actual bandwidth used by any specific PGID may vary from configured values by up to 10% of the available bandwidth in accordance with 802.1Qaz ETS standard. For example, a setting of 10% may be served anywhere from 0% to 20% of the available bandwidth at any given time.

### Unlimited Bandwidth for PGID 15

PGID 15 is permitted unlimited bandwidth and is generally intended for critical traffic (such as SI4093 management). Traffic in this group is given highest priority and is served before the traffic in any other priority group.

If PGID 15 has low traffic levels, most of the system's bandwidth will be available to serve priority groups 0 through 7. However, if PGID 15 consumes a larger part of the system's total bandwidth, the amount available to the other groups is reduced.

**Note:** Consider traffic load when assigning priority values to PGID 15. Heavy traffic in this group may restrict the bandwidth available to other groups.

## Configuring ETS

Consider an example consistent with that used for port-based PFC configuration (on [page 128](#)):

Table 16. ETS Configuration

Priority	Usage	PGID	Bandwidth
0	LAN (best effort delivery)	0	10%
1	LAN (best effort delivery)		
2	LAN (best effort delivery)		
3	SAN (Fibre Channel over Ethernet, with PFC)	1	20%
4	Business Critical LAN (lossless Ethernet, with PFC)	2	30%
5	Latency-sensitive LAN	3	40%
6	Latency-sensitive LAN		
7	Network Management (strict)	15	unlimited

The example shown in [Table 16](#) is only slightly different than the default configuration shown in [Figure 12 on page 130](#). In this example, latency-sensitive LAN traffic (802.1p priority 5 through 6) are moved from priority group 2 to priority group 3. This leaves Business Critical LAN traffic (802.1p priority 4) in priority group 2 by itself. Also, a new group for network management traffic has been assigned. Finally, the bandwidth allocation for priority groups 1, 2, and 3 are revised.

**Note:** DCBX may be configured to permit sharing or learning PFC configuration with or from external devices. This example assumes that PFC configuration is being performed manually. See [“Data Center Bridging Capability Exchange” on page 136](#) for more information on DCBX.

This example can be configured using the following commands:

1. Turn CEE on.

```
SI 4093(config)# cee enable
```

2. Configure each allocated priority group with a description (optional), list of 802.1p priority values, and bandwidth allocation:

```
SI 4093(config)# cee global ets priority-group pgid 0 description "Regular Lan"
                                     (Select a group for regular LAN) and set a group
                                     description—optional)
SI 4093(config)# cee global ets priority-group pgid 0 bandwidth 10
                                     (Restrict to 10% of link bandwidth)
SI 4093(config)# cee global ets priority-group pgid 0 prio 0,1,2
                                     (Set 802.1p priority 0, 1, and 2)
SI 4093(config)# cee global ets priority-group pgid 1 bandwidth 20
                                     (Select a group for SAN traffic and restrict 20%
                                     of link bandwidth)
SI 4093(config)# cee global ets priority-group pgid 1 desc "SAN"
                                     (Set a group description—optional)
SI 4093(config)# cee global ets priority-group pgid 1 prio 3
                                     (Set 802.1p priority 3 for the group)
SI 4093(config)# cee global ets priority-group pgid 2 bandwidth 30
                                     (Select a group for latency traffic and restrict 30%
                                     of link bandwidth)
SI 4093(config)# cee global ets priority-group pgid 2 desc "Business Critical
LAN"
                                     (Set a group description—optional)
SI 4093(config)# cee global ets priority-group pgid 2 prio 4
                                     (Set 802.1p priority 4)
```

3. Configure the strict priority group with a description (optional) and a list of 802.1p priority values:

```
SI 4093(config)# cee global ets priority-group pgid 15 priority 7
                                     (Select a group for strict traffic and set 802.1p
                                     priority 7)
SI 4093(config)# cee global ets priority-group pgid 15 desc "Network Management"
                                     (Set a group description—optional)
```

**Note:** Priority group 15 is permitted unlimited bandwidth. As such, the commands for priority group 15 do not include bandwidth allocation.

4. Save the configuration.

```
SI 4093(config)# copy running-config startup-config
```

---

## Data Center Bridging Capability Exchange

Data Center Bridging Capability Exchange (DCBX) protocol is a vital element of CEE. DCBX allows peer CEE devices to exchange information about their advanced capabilities. Using DCBX, neighboring network devices discover their peers, negotiate peer configurations, and detect misconfigurations.

DCBX provides two main functions on the SI4093:

- Peer information exchange  
The SI4093 uses DCBX to exchange information with connected CEE devices. For normal operation of any FCoE implementation on the SI4093, DCBX must remain enabled on all ports participating in FCoE.
- Peer configuration negotiation  
DCBX also allows CEE devices to negotiate with each other for the purpose of automatically configuring advanced CEE features such as PFC, ETS, and (for some CNAs) FIP. The administrator can determine which CEE feature settings on the SI4093 are communicated to and matched by CEE neighbors, and also which CEE feature settings on the SI4093 may be configured by neighbor requirements.

The DCBX feature requires CEE to be turned on (see [“Turning CEE On or Off” on page 118](#)).

## DCBX Settings

When CEE is turned on, DCBX is enabled for peer information exchange on all ports. For configuration negotiation, the following default settings are configured:

- Application Protocol: FCoE and FIP snooping is set for traffic with 802.1p priority 3
- PFC: Enabled on 802.1p priority 3
- ETS
  - Priority group 0 includes priority values 0 through 2, with bandwidth allocation of 10%
  - Priority group 1 includes priority value 3, with bandwidth allocation of 50%
  - Priority group 2 includes priority values 4 through 7, with bandwidth allocation of 40%



## Enabling and Disabling DCBX

When CEE is turned on, DCBX can be enabled and disabled on a per-port basis, using the following commands:

```
SI 4093(config)# cee port <port alias or number> dcbx enable  
  
-or-  
  
SI 4093(config)# no cee port <port alias or number> dcbx enable
```

When DCBX is enabled on a port, Link Layer Detection Protocol (LLDP) is used to exchange DCBX parameters between CEE peers. Also, the interval for LLDP transmission time is set to one second for the first five initial LLDP transmissions, after which it is returned to the administratively configured value. The minimum delay between consecutive LLDP frames is also set to one second as a DCBX default.

## Peer Configuration Negotiation

CEE peer configuration negotiation can be set on a per-port basis for a number of CEE features. For each supported feature, the administrator can configure two independent flags:

- **The advertise flag**  
When this flag is set for a particular feature, the SI4093 settings will be transmitted to the remote CEE peer. If the peer is capable of the feature, and willing to accept the SI4093 settings, it will be automatically reconfigured to match the SI4093.
- **The willing flag**  
Set this flag when required by the remote CEE peer for a particular feature as part of DCBX signaling and support. Although some devices may also expect this flag to indicate that the SI4093 will accept overrides on feature settings, the SI4093 retains its configured settings. As a result, the administrator should configure the feature settings on the SI4093 to match those expected by the remote CEE peer.

These flags are available for the following CEE features:

- **Application Protocol**  
DCBX exchanges information regarding FCoE and FIP snooping, including the 802.1p priority value used for FCoE traffic. The `advertise` flag is set or reset using the following commands:

```
SI 4093(config)# cee port <port alias or number> dcbx app_proto advertise  
  
SI 4093(config)# no cee port <port alias or number> dcbx app_proto advertise
```

The `willing` flag is set or reset using the following commands:

```
SI 4093(config)# cee port <port alias or number> dcbx app_proto willing  
  
SI 4093(config)# no cee port <port alias or number> dcbx app_proto willing
```

- PFC

DCBX exchanges information regarding whether PFC is enabled or disabled on the port. The `advertise` flag is set or reset using the following commands:

```
SI 4093(config)# cee port <port alias or number> dcbx pfc advertise
SI 4093(config)# no cee port <port alias or number> dcbx pfc advertise
```

The `willing` flag is set or reset using the following commands:

```
SI 4093(config)# cee port <port alias or number> dcbx pfc willing
SI 4093(config)# no cee port <port alias or number> dcbx pfc willing
```

- ETS

DCBX exchanges information regarding ETS priority groups, including their 802.1p priority members and bandwidth allocation percentages. The `advertise` flag is set or reset using the following command:

```
>> # /cfg/cee/port <port alias or number>/dcbx/etsadv {ena|dis}
```

The `willing` flag is set or reset using the following command:

```
>> # /cfg/cee/port <port alias or number>/dcbx/etswill {ena|dis}
```

## Configuring DCBX

Consider an example consistent [Figure on page 116](#) and used with the previous FCoE examples in this chapter:

- FCoE is used on ports INTA1 and EXT4.
- CEE features are also used with LANs on ports INTA2 and EXT5.
- All other ports are disabled or are connected to regular (non-CEE) LAN devices.

In this example, the SI4093 acts as the central point for CEE configuration. FCoE-related ports will be configured for advertising CEE capabilities, but not to accept external configuration. Other LAN ports that use CEE features will also be configured to advertise feature settings to remote peers, but not to accept external configuration. DCBX will be disabled on all non-CEE ports.

This example can be configured using the following commands:

1. Turn CEE on.

```
SI 4093(config)# cee enable
```

2. Enable desired DCBX configuration negotiation on FCoE ports:

```
SI 4093(config)# cee port INTA1 dcbx enable
SI 4093(config)# cee port INTA1 dcbx app adv
SI 4093(config)# cee port INTA1 dcbx pfc adv
SI 4093(config)# cee port INTA1 dcbx ets adv

SI 4093(config)# cee port EXT4 dcbx enable
SI 4093(config)# cee port EXT4 dcbx app adv
SI 4093(config)# cee port EXT4 dcbx pfc adv
SI 4093(config)# cee port EXT4 dcbx ets adv
```

**Note:** To verify DCBX settings for each port, use the `cur` command:

```
SI 4093(config)# show cee port INTA1 dcbx

Current DCBX Configuration on port INTA1:

Alias Port DCBX State Feature      State    Willing  Advertise
-----
INTA1 1    Enabled  ETS      Disabled Disabled Enabled
INTA1 1    Enabled  PFC      Enabled  Disabled Enabled
INTA1 1    Enabled  App Proto Disabled Disabled Enabled
```

3. Enable desired DCBX advertisements on other CEE ports:

```
SI 4093(config)# cee port INTA2 dcbx enable
SI 4093(config)# cee port INTA2 dcbx app
SI 4093(config)# cee port INTA2 dcbx pfc adv
SI 4093(config)# cee port INTA2 dcbx ets adv

SI 4093(config)# cee port EXT5 dcbx enable
SI 4093(config)# cee port EXT5 dcbx app adv
SI 4093(config)# cee port EXT5 dcbx pfc adv
SI 4093(config)# cee port EXT5 dcbx ets adv
```

4. Disable DCBX for each non-CEE port as appropriate:

```
SI 4093(config)# no cee port INTA3 dcbx enable
SI 4093(config)# no cee port INTA4 dcbx enable
...
SI 4093(config)# no cee port EXT11 dcbx enable
```

5. Save the configuration.

```
SI 4093(config)# copy running-config startup-config
```

## FCoE Example Configuration

The following example collects the various components from previous sections of this chapter.

Figure 13. A Mixed Fibre Channel and FCoE Network

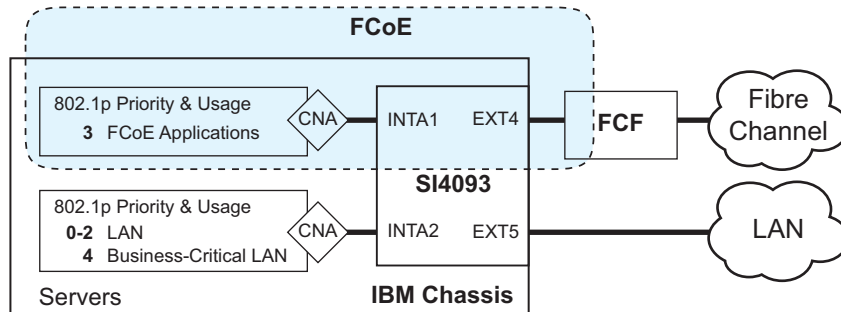

In [Figure 13 on page 140](#), the Fibre Channel network is connected to the FCoE network through an FCF bridge module on port EXT4. The FCoE-enabled SI4093 is internally connected to a blade server (ENode) through an FCoE-enabled CNA on port INTA1. All participating ports are members of the same VLAN-aware SPAR.

1. Disable FIP snooping on all non-FCoE external ports:

```
SI 4093(config)# no fcoe fips port ext1-ext3,ext5-ext10 enable
```

1. (Set by default) Turn global FIP snooping on:

```
SI 4093(config)# fcoe fips enable
```

2. Make sure CEE is turned on (the default setting). If CEE has been previously turned off, turn it on using the following command:

```
SI 4093(config)# cee enable
```

**Note:** Turning CEE on or off will automatically change some 802.1p QoS and 802.3x standard flow control settings (see [“Turning CEE On or Off” on page 118](#)).

3. Configure a VLAN-aware SPAR for use with FCoE:

```
SI 4093(config)# spar 2
SI 4093(config-spar)# uplink port ext4
SI 4093(config-spar)# domain mode local
SI 4093(config-spar)# domain default vlan 4082
SI 4093(config-spar)# domain default member inta1
```

4. Add the FCoE VLAN to the SPAR, with all FCoE member internal ports:

```
SI 4093(config-spar)# domain local 1 vlan 1002
SI 4093(config-spar)# domain local 1 member inta1
SI 4093(config-spar)# domain local 1 name vid1002
SI 4093(config-spar)# domain local 1 enable
```

5. Enable the SPAR and exit SPAR configuration:

```
SI 4093(config-spar)# enable
SI 4093(config-spar)# exit
```

6. Enable FIP snooping on FCoE ports, and set the desired FCF mode:

```
SI 4093(config-VLAN)# fcoe fips port INTA1 enable
                                     (Select ENode port and enable FIP
                                     snooping on port)
SI 4093(config-VLAN)# fcoe fips port INTA1 fcfmode off
                                     (Set as ENode connection)
SI 4093(config-VLAN)# fcoe fips port EXT4 enable
                                     (Select FCF module port A and enable FIP
                                     snooping on port)
SI 4093(config-VLAN)# fcoe fips port EXT4 fcfmode on
                                     (Set as FCF connection)
```

7. (Set by default) Enable PFC for the FCoE traffic.

```
SI 4093(config)# cee port INTA1 pfc      (Turn on PFC for port) INTA1)
SI 4093(config)# cee port INTA1 pfc priority 3 enable
                                     (Select and enable FCoE priority 3 PFC for the port)
SI 4093(config)# cee port INTA1 pfc priority 3 description "FCoE"
                                     (Set priority description—optional)
SI 4093(config)# cee port EXT4 pfc      (Select and enable FCoE for port EXT4)
SI 4093(config)# cee port EXT4 pfc priority 3 enable
                                     (Select and enable FCoE priority 3 PFC for the port)
SI 4093(config)# cee port EXT4 pfc priority 3 description "FCoE"
                                     (Set priority description—optional)
```

8. Enable PFC for the business-critical LAN application:

```
SI 4093(config)# cee port INTA2 pfc      (Turn on PFC for port) INTA2)
SI 4093(config)# cee port INTA2 pfc priority 4 enable
                                     (Select and enable FCoE priority 4 PFC for the port)
SI 4093(config)# cee port INTA2 pfc priority 4 description "Business-critical
LAN"
                                     (Set priority description—optional)
SI 4093(config)# cee port EXT5 pfc      (Select and enable FCoE for port EXT5)
SI 4093(config)# cee port EXT5 pfc priority 4 enable
                                     (Select and enable FCoE priority 4 PFC for the port)
SI 4093(config)# cee port EXT5 pfc priority 4 description "Business-critical
LAN"
                                     (Set priority description—optional)
```

9. For ETS, allocate bandwidth for each priority group:

```
SI 4093(config)# cee global ets priority-group pgid 0 bandwidth 10
                                     (Select a group for regular LAN and restrict to
                                     10% of link bandwidth)
SI 4093(config)# cee global ets priority-group pgid 0 prio 0,1,2
                                     (Set 802.1p priority 0, 1, and 2)
SI 4093(config)# cee global ets priority-group pgid 1 bandwidth 20
                                     (Select a group for SAN traffic and restrict 20%
                                     of link bandwidth))
SI 4093(config)# cee global ets priority-group pgid 1 prio 3
                                     (Set 802.1p priority 3 for the group)
SI 4093(config)# cee global ets priority-group pgid 2 bandwidth 30
                                     (Select a group for latency traffic and restrict 30%
                                     of link bandwidth)
SI 4093(config)# cee global ets priority-group pgid 2 prio 4
                                     (Set 802.1p priority 4)
SI 4093(config)# cee global ets priority-group pgid 3 bandwidth 40
                                     (Select a group for latency traffic and restrict 40%
                                     of link bandwidth)
SI 4093(config)# cee global ets priority-group pgid 3 prio 5,6
                                     (Set 802.1p priorities 5 and 6)
```

**Note:** Do not place PFC-enabled traffic queues and non-PFC traffic queues in the same priority group, as this may result in unexpected network behavior.

10. Configure the strict priority group:

```
SI 4093(config)# cee global ets priority-group pgid 15 priority 7
                                     (Select a group for strict traffic and set 802.1p
                                     priority 7)
```

11. Enable desired DCBX configuration negotiation on FCoE ports:

```
SI 4093(config)# cee port INTA1 dcbx enable
SI 4093(config)# cee port INTA1 dcbx app adv
SI 4093(config)# cee port INTA1 dcbx pfc adv
SI 4093(config)# cee port INTA1 dcbx ets adv

SI 4093(config)# cee port EXT4 dcbx enable
SI 4093(config)# cee port EXT4 dcbx app adv
SI 4093(config)# cee port EXT4 dcbx pfc adv
SI 4093(config)# cee port EXT4 dcbx ets adv
```

12. Enable desired DCBX advertisements on other CEE ports:

```
SI 4093(config)# cee port INTA2 dcbx enable
SI 4093(config)# cee port INTA2 dcbx app
SI 4093(config)# cee port INTA2 dcbx pfc adv
SI 4093(config)# cee port INTA2 dcbx ets adv

SI 4093(config)# cee port EXT5 dcbx enable
SI 4093(config)# cee port EXT5 dcbx app adv
SI 4093(config)# cee port EXT5 dcbx pfc adv
SI 4093(config)# cee port EXT5 dcbx ets adv
```

13. Disable DCBX for each non-CEE port as appropriate:

```
SI 4093(config)# no cee port INTA3 dcbx enable
SI 4093(config)# no cee port INTA4 dcbx enable
...
SI 4093(config)# no cee port EXT11 dcbx enable
```

14. Save the configuration.

```
SI 4093(config)# copy running-config startup-config
```





---

## Chapter 16. Link Layer Discovery Protocol

The IBM Networking OS software support Link Layer Discovery Protocol (LLDP). This chapter discusses the use and configuration of LLDP on the switch:

- [“LLDP Overview” on page 145](#)
- [“Enabling or Disabling LLDP” on page 146](#)
- [“LLDP Transmit Features” on page 147](#)
- [“LLDP Receive Features” on page 150](#)
- [“LLDP Example Configuration” on page 152](#)

---

### LLDP Overview

Link Layer Discovery Protocol (LLDP) is an IEEE 802.1AB-2005 standard for discovering and managing network devices. LLDP uses Layer 2 (the data link layer), and allows network management applications to extend their awareness of the network by discovering devices that are direct neighbors of already known devices.

With LLDP, the SI4093 can advertise the presence of its ports, their major capabilities, and their current status to other LLDP stations in the same LAN. LLDP transmissions occur on ports at regular intervals or whenever there is a relevant change to their status. The switch can also receive LLDP information advertised from adjacent LLDP-capable network devices.

In addition to discovery of network resources, and notification of network changes, LLDP can help administrators quickly recognize a variety of common network configuration problems, such as unintended VLAN exclusions or mis-matched port aggregation membership.

The LLDP transmit function and receive function can be independently configured on a per-port basis. The administrator can allow any given port to transmit only, receive only, or both transmit and receive LLDP information.

The LLDP information to be distributed by the SI4093 ports, and that which has been collected from other LLDP stations, is stored in the switch's Management Information Base (MIB). Network Management Systems (NMS) can use Simple Network Management Protocol (SNMP) to access this MIB information. LLDP-related MIB information is read-only.

Changes, either to the local switch LLDP information or to the remotely received LLDP information, are flagged within the MIB for convenient tracking by SNMP-based management systems.

For LLDP to provide expected benefits, all network devices that support LLDP should be consistent in their LLDP configuration.

---

## Enabling or Disabling LLDP

### Global LLDP Setting

By default, LLDP is enabled on the SI4093. To turn LLDP off or on, use the following commands:

```
SI 4093(config)# [no] lldp enable (Turn LLDP on or off globally)
```

### Transmit and Receive Control

The SI4093 can also be configured to transmit or receive LLDP information on a port-by-port basis. By default, when LLDP is globally enabled on the switch, SI4093 ports transmit and receive LLDP information (see the `tx_rx` option below). To change the LLDP transmit and receive state, the following commands are available:

```
SI 4093(config)# interface port <n> (Select a switch port)  
SI 4093(config-if)# lldp admin-status tx_rx (Transmit and receive LLDP)  
SI 4093(config-if)# lldp admin-status tx_only (Only transmit LLDP)  
SI 4093(config-if)# lldp admin-status rx_only (Only receive LLDP)  
SI 4093(config-if)# no lldp admin-status (Do not participate in LLDP)  
SI 4093(config-if)# exit (Exit port mode)
```

To view the LLDP transmit and receive status, use the following commands:

```
SI 4093(config)# show lldp port (status of all ports)  
SI 4093(config)# show interface port <n> lldp (status of selected port)
```

---

## LLDP Transmit Features

Numerous LLDP transmit options are available, including scheduled and minimum transmit interval, expiration on remote systems, SNMP trap notification, and the types of information permitted to be shared.

### Scheduled Interval

The SI4093 can be configured to transmit LLDP information to neighboring devices once each 5 to 32768 seconds. The scheduled interval is global; the same interval value applies to all LLDP transmit-enabled ports. However, to help balance LLDP transmissions and keep them from being sent simultaneously on all ports, each port maintains its own interval clock, based on its own initialization or reset time. This allows switch-wide LLDP transmissions to be spread out over time, though individual ports comply with the configured interval.

The global transmit interval can be configured using the following command:

```
SI 4093(config)# lldp refresh-interval <interval>
```

where *interval* is the number of seconds between LLDP transmissions. The range is 5 to 32768. The default is 30 seconds.

### Minimum Interval

In addition to sending LLDP information at scheduled intervals, LLDP information is also sent when the SI4093 detects relevant changes to its configuration or status (such as when ports are enabled or disabled). To prevent the SI4093 from sending multiple LLDP packets in rapid succession when port status is in flux, a transmit delay timer can be configured.

The transmit delay timer represents the minimum time permitted between successive LLDP transmissions on a port. Any interval-driven or change-driven updates will be consolidated until the configured transmit delay expires.

The minimum transmit interval can be configured using the following command:

```
SI 4093(config)# lldp transmission-delay <interval>
```

where *interval* is the minimum number of seconds permitted between successive LLDP transmissions on any port. The range is 1 to one-quarter of the scheduled transmit interval (`msgtxint`), up to 8192. The default is 2 seconds.

## Time-to-Live for Transmitted Information

The transmitted LLDP information is held by remote systems for a limited time. A time-to-live parameter allows the switch to determine how long the transmitted data should be held before it expires. The hold time is configured as a multiple of the configured transmission interval.

```
SI 4093(config)# lldp holdtime-multiplier <multiplier>
```

where *multiplier* is a value between 2 and 10. The default value is 4, meaning that remote systems will hold the port's LLDP information for 4 x the 30-second `msgtxint` value, or 120 seconds, before removing it from their MIB.

## Trap Notifications

If SNMP is enabled on the SI4093 (see [“Using Simple Network Management Protocol” on page 22](#)), each port can be configured to send SNMP trap notifications whenever LLDP transmissions are sent. By default, trap notification is disabled for each port. The trap notification state can be changed using the following commands):

```
SI 4093(config)# interface port 1
SI 4093(config-if)# [no] lldp trap-notification
SI 4093(config-if)# exit
```

In addition to sending LLDP information at scheduled intervals, LLDP information is also sent when the SI4093 detects relevant changes to its configuration or status (such as when ports are enabled or disabled). To prevent the SI4093 from sending multiple trap notifications in rapid succession when port status is in flux, a global trap delay timer can be configured.

The trap delay timer represents the minimum time permitted between successive trap notifications on any port. Any interval-driven or change-driven trap notices from the port will be consolidated until the configured trap delay expires.

The minimum trap notification interval can be configured using the following command:

```
SI 4093(config)# lldp trap-notification-interval <interval>
```

where *interval* is the minimum number of seconds permitted between successive LLDP transmissions on any port. The range is 1 to 3600. The default is 5 seconds.

If SNMP trap notification is enabled, the notification messages can also appear in the system log. This is enabled by default. To change whether the SNMP trap notifications for LLDP events appear in the system log, use the following command

```
SI 4093(config)# [no] logging log lldp
```

## Changing the LLDP Transmit State

When the port is disabled, or when LLDP transmit is turned off for the port using the `admstat` command's `rx_only` or `disabled` options (see [“Transmit and Receive Control” on page 146](#)), a final LLDP packet is transmitted with a time-to-live value of 0. Neighbors that receive this packet will remove the LLDP information associated with the SI4093 port from their MIB.

In addition, if LLDP is fully disabled on a port (using `admstat disabled`) and later re-enabled, the SI4093 will temporarily delay resuming LLDP transmissions on the port in order to allow the port LLDP information to stabilize. The reinitialization delay interval can be globally configured for all ports using the following command::

```
SI 4093(config)# lldp reinit-delay <interval>
```

where *interval* is the number of seconds to wait before resuming LLDP transmissions. The range is between 1 and 10. The default is 2 seconds.

## Types of Information Transmitted

When LLDP transmission is permitted on the port (see [“Enabling or Disabling LLDP” on page 146](#)), the port advertises the following required information in type/length/value (TLV) format:

- Chassis ID
- Port ID
- LLDP Time-to-Live

LLDP transmissions can also be configured to enable or disable inclusion of optional information, using the following command:

```
SI 4093(config)# interface port 1
SI 4093(config-if)# [no] lldp tlv <type>
SI 4093(config-if)# exit
```

where *type* is an LLDP information option from [Table 17](#):

Table 17. LLDP Optional Information Types

Type	Description	Default
portdesc	Port Description	Enabled
sysname	System Name	Enabled
sysdescr	System Description	Enabled
syscap	System Capabilities	Enabled
mgmtaddr	Management Address	Enabled
portvid	IEEE 802.1 Port VLAN ID	Disabled
portprot	IEEE 802.1 Port and Protocol VLAN ID	Disabled
vlanname	IEEE 802.1 VLAN Name	Disabled
protid	IEEE 802.1 Protocol Identity	Disabled

Table 17. LLDP Optional Information Types (continued)

Type	Description	Default
macphy	IEEE 802.3 MAC/PHY Configuration/Status, including the auto-negotiation, duplex, and speed status of the port.	Disabled
powermdi	IEEE 802.3 Power via MDI, indicating the capabilities and status of devices that require or provide power over twisted-pair copper links.	Disabled
linkaggr	IEEE 802.3 Link Aggregation status for the port.	Disabled
framesz	IEEE 802.3 Maximum Frame Size for the port.	Disabled
dcbx	Data Center Bridging Capability Exchange Protocol (DCBX) for the port.	Enabled
all	Select all optional LLDP information for inclusion or exclusion.	Disabled

---

## LLDP Receive Features

### Types of Information Received

When the LLDP receive option is enabled on a port (see [“Enabling or Disabling LLDP” on page 146](#)), the port may receive the following information from LLDP-capable remote systems:

- Chassis Information
- Port Information
- LLDP Time-to-Live
- Port Description
- System Name
- System Description
- System Capabilities Supported/Enabled
- Remote Management Address

The SI4093 stores the collected LLDP information in the MIB. Each remote LLDP-capable device is responsible for transmitting regular LLDP updates. If the received updates contain LLDP information changes (to port state, configuration, LLDP MIB structures, deletion), the switch will set a change flag within the MIB for convenient notification to SNMP-based management systems.

## Viewing Remote Device Information

LLDP information collected from neighboring systems can be viewed in numerous ways:

- Using a centrally-connected LLDP analysis server
- Using an SNMP agent to examine the SI4093 MIB
- Using CLI commands on the SI4093

Using the CLI, the following command displays remote LLDP information:

```
SI 4093(config)# show lldp remote-device [<index number>]
```

To view a summary of remote information, omit the *Index number* parameter. For example:

```
SI 4093(config)# show lldp remote-device
LLDP Remote Devices Information

LocalPort | Index | Remote Chassis ID | Remote Port | Remote System Name
-----|-----|-----|-----|-----
3         | 1    | 00 18 b1 33 1d 00 | 23         |
```

To view detailed information for a remote device, specify the *Index number* as found in the summary. For example, in keeping with the sample summary, to list details for the first remote device (with an *Index* value of 1), use the following command:

```
SI 4093(config)# show lldp remote-device 1
Local Port Alias: 3
  Remote Device Index      : 1
  Remote Device TTL        : 99
  Remote Device RxChanges  : false
  Chassis Type              : Mac Address
  Chassis Id                : 00-18-b1-33-1d-00
  Port Type                 : Locally Assigned
  Port Id                   : 23
  Port Description          : 7

  System Name               :
  System Description        : IBM Networking OS Virtual Fabric 10Gb
                             Switch Module for IBM BladeCenter,
                             flash image: version 6.9.0,
                             boot image: version 6.9.0

  System Capabilities Supported : bridge, router
  System Capabilities Enabled   : bridge, router

  Remote Management Address:
    Subtype                   : IPv4
    Address                    : 10.100.120.181
    Interface Subtype          : ifIndex
    Interface Number           : 128
    Object Identifier          :
```

**Note:** Received LLDP information can change very quickly. When using information commands, it is possible that flags for some expected events may be too short-lived to be observed in the output.

## Time-to-Live for Received Information

Each remote device LLDP packet includes an expiration time. If the switch port does not receive an LLDP update from the remote device before the time-to-live clock expires, the switch will consider the remote information to be invalid, and will remove all associated information from the MIB.

Remote devices can also intentionally set their LLDP time-to-live to 0, indicating to the switch that the LLDP information is invalid and should be immediately removed.

---

## LLDP Example Configuration

1. Turn LLDP on globally.

```
SI 4093(config)# lldp enable
```

2. Set the global LLDP timer features.

```
SI 4093(config)# lldp refresh-interval 30 (Transmit each 30 seconds)
SI 4093(config)# lldp transmission-delay 2 (No more often than 2 sec.)
SI 4093(config)# lldp holdtime-multiplier 4 (Remote hold 4 intervals)
SI 4093(config)# lldp reinit-delay 2 (Wait 2 sec. after reinit.)
SI 4093(config)# lldp trap-notification-interval 5 (Minimum 5 sec. between)
```

3. Set LLDP options for each port.

```
SI 4093(config)# interface port <n> (Select a switch port)
SI 4093(config-if)# lldp admin-status tx_rx (Transmit and receive LLDP)
SI 4093(config-if)# lldp trap-notification (Enable SNMP trap notifications)
SI 4093(config-if)# lldp tlv all (Transmit all optional information)
SI 4093(config-if)# exit
```

4. Enable syslog reporting.

```
SI 4093(config)# logging log lldp
```

5. Save the configuration.

```
SI 4093(config)# copy running-config startup-config
```

6. Verify the configuration settings

```
SI 4093(config)# show lldp
```

7. View remote device information as needed.

```
SI 4093(config)# show lldp remote-device
or
SI 4093(config)# show lldp remote-device <index number>
```



---

## Chapter 17. Simple Network Management Protocol

IBM Networking OS provides Simple Network Management Protocol (SNMP) version 1, version 2, and version 3 support for access through any network management software, such as IBM Director.

---

### SNMP Version 1

To access the SNMP agent on the SI4093, the read and write community strings on the SNMP manager should be configured to match those on the switch. The default read community string on the switch is `public` and the default write community string is `private`.

The read and write community strings on the switch can be changed using the following commands on the CLI:

```
SI 4093(config)# snmp-server read-community <1-32 characters>
-and-
SI 4093(config)# snmp-server write-community <1-32 characters>
```

The SNMP manager should be able to reach the management interface or any one of the IP interfaces on the switch.

For the SNMP manager to receive the SNMPv1 traps sent out by the SNMP agent on the switch, configure the trap host on the switch with the following command:

```
SI 4093(config)# snmp-server trap-src-if <trap source IP interface>
SI 4093(config)# snmp-server host <IPv4 address> <trap host community string>
```

---

### SNMP Version 3

SNMP version 3 (SNMPv3) is an enhanced version of the Simple Network Management Protocol, approved by the Internet Engineering Steering Group in March, 2002. SNMPv3 contains additional security and authentication features that provide data origin authentication, data integrity checks, timeliness indicators and encryption to protect against threats such as masquerade, modification of information, message stream modification and disclosure.

SNMPv3 allows clients to query the MIBs securely.

SNMPv3 configuration is managed using the following menu:

```
SI 4093(config)# snmp-server user <1-16> name <1-32 characters>
```

For more information on SNMP MIBs and the commands used to configure SNMP on the switch, see the *IBM Networking OS 7.7 Command Reference*.

#### Default Configuration

IBM Networking OS has two SNMPv3 users by default. Both of the following users have access to all the MIBs supported by the switch:

- User 1 name is `adminmd5` (password `adminmd5`). Authentication used is MD5.
- User 2 name is `adminsha` (password `adminsha`). Authentication used is SHA.

Up to 16 SNMP users can be configured on the switch. To modify an SNMP user, enter the following commands :

```
SI 4093(config)# snmp-server user <1-16> name <1-32 characters>
```

Users can be configured to use the authentication/privacy options. The SI4093 support two authentication algorithms: MD5 and SHA, as specified in the following command :

```
SI 4093(config)# snmp-server user <1-16> authentication-protocol {md5 | sha }
authentication-password
-or-
SI 4093(config)# snmp-server user <1-16> authentication-protocol none
```

### User Configuration Example

1. To configure a user with name “admin,” authentication type MD5, and authentication password of “admin,” privacy option DES with privacy password of “admin,” use the following CLI commands. .

```
SI 4093(config)# snmp-server user 5 name admin
SI 4093(config)# snmp-server user 5 authentication-protocol md5
authentication-password
Changing authentication password; validation required:
Enter current admin password: <admin.password>
Enter new authentication password: <auth.password>
Re-enter new authentication password: <auth.password>
New authentication password accepted.

SI 4093(config)# snmp-server user 5 privacy-protocol des privacy-password
Changing privacy password; validation required:
Enter current admin password: <admin.password>
Enter new privacy password: <privacy.password>
Re-enter new privacy password: <privacy.password>
New privacy password accepted.
```

2. Configure a user access group, along with the views the group may access. Use the access table to configure the group’s access level. .

```
SI 4093(config)# snmp-server access 5 name admingrp
SI 4093(config)# snmp-server access 5 level authpriv
SI 4093(config)# snmp-server access 5 read-view iso
SI 4093(config)# snmp-server access 5 write-view iso
SI 4093(config)# snmp-server access 5 notify-view iso
```

Because the read view (rview), write view (wview), and notify view (nview) are all set to “iso,” the user type has access to all private and public MIBs.

3. Assign the user to the user group. Use the group table to link the user to a particular access group. .

```
SI 4093(config)# snmp-server group 5 user-name admin
SI 4093(config)# snmp-server group 5 group-name admingrp
```

If you want to allow user access only to certain MIBs, see “View-Based Configuration,” next.

---

## Configuring SNMP Trap Hosts

### SNMPv1 Trap Host

1. Configure a user with no authentication and password

```
SI 4093(config)# snmp-server user 10 name v1trap
```

2. Configure an access group and group table entries for the user. Use the following menu to specify which traps can be received by the user:

```
SI 4093(config)# snmp-server access <user number>
```

In the following example the user will receive the traps sent by the switch.

```
SI 4093(config)# snmp-server access 10           (Access group to view SNMPv1 traps)
  name v1trap
  security snmpv1
  notify-view iso
SI 4093(config)# snmp-server group 10           (Assign user to the access group)
  security snmpv1
  user-name v1trap
  group-name v1trap
```

3. Configure an entry in the notify table. .

```
SI 4093(config)# snmp-server notify 10 name v1trap
SI 4093(config)# snmp-server notify 10 tag v1trap
```

4. Specify the IPv4 address and other trap parameters in the `targetAddr` and `targetParam` tables. Use the following menus to specify the user name associated with the `targetParam` table: :

```
SI 4093(config)# snmp-server target-address 10 name v1trap address 10.70.70.190
SI 4093(config)# snmp-server target-address 10 parameters-name vlparam
SI 4093(config)# snmp-server target-address 10 taglist vlparam
SI 4093(config)# snmp-server target-parameters 10 name vlparam
SI 4093(config)# snmp-server target-parameters 10 user-name vlonly
SI 4093(config)# snmp-server target-parameters 10 message snmpv1
```

**Note:** IBM Networking OS 7.7 supports only IPv4 addresses for SNMP trap hosts.

5. Use the community table to specify which community string is used in the trap..

```
SI 4093(config)# snmp-server community 10       (Define the community string)
  index v1trap
  name public
  user-name v1trap
```

## SNMPv2 Trap Host Configuration

The SNMPv2 trap host configuration is similar to the SNMPv1 trap host configuration. Wherever you specify the model, use `snmpv2` instead of `snmpv1`.

```
SI 4093(config)# snmp-server user 10 name v2trap

SI 4093(config)# snmp-server group 10 security snmpv2
SI 4093(config)# snmp-server group 10 user-name v2trap
SI 4093(config)# snmp-server group 10 group-name v2trap
SI 4093(config)# snmp-server access 10 name v2trap
SI 4093(config)# snmp-server access 10 security snmpv2
SI 4093(config)# snmp-server access 10 notify-view iso

SI 4093(config)# snmp-server notify 10 name v2trap
SI 4093(config)# snmp-server notify 10 tag v2trap

SI 4093(config)# snmp-server target-address 10 name v2trap address 100.10.2.1
SI 4093(config)# snmp-server target-address 10 taglist v2trap
SI 4093(config)# snmp-server target-address 10 parameters-name v2param
SI 4093(config)# snmp-server target-parameters 10 name v2param
SI 4093(config)# snmp-server target-parameters 10 message snmpv2c
SI 4093(config)# snmp-server target-parameters 10 user-name v2trap
SI 4093(config)# snmp-server target-parameters 10 security snmpv2

SI 4093(config)# snmp-server community 10 index v2trap
SI 4093(config)# snmp-server community 10 user-name v2trap
```

**Note:** IBM Networking OS 7.7 supports only IPv4 addresses for SNMP trap hosts.

## SNMPv3 Trap Host Configuration

To configure a user for SNMPv3 traps, you can choose to send the traps with both privacy and authentication, with authentication only, or without privacy or authentication.

This is configured in the access table using the following commands :

```
SI 4093(config)# snmp-server access <I-32> level
SI 4093(config)# snmp-server target-parameters <I-16>
```

Configure the user in the user table accordingly.

It is not necessary to configure the community table for SNMPv3 traps because the community string is not used by SNMPv3.

The following example shows how to configure a SNMPv3 user v3trap with authentication only: :

```
SI 4093(config)# snmp-server user 11 name v3trap
SI 4093(config)# snmp-server user 11 authentication-protocol md5
authentication-password
Changing authentication password; validation required:
Enter current admin password: <admin.password>
Enter new authentication password: <auth.password>
Re-enter new authentication password: <auth.password>
New authentication password accepted.
SI 4093(config)# snmp-server access 11 notify-view iso
SI 4093(config)# snmp-server access 11 level authnopriv
SI 4093(config)# snmp-server group 11 user-name v3trap
SI 4093(config)# snmp-server group 11 tag v3trap
SI 4093(config)# snmp-server notify 11 name v3trap
SI 4093(config)# snmp-server notify 11 tag v3trap
SI 4093(config)# snmp-server target-address 11 name v3trap address 47.81.25.66
SI 4093(config)# snmp-server target-address 11 taglist v3trap
SI 4093(config)# snmp-server target-address 11 parameters-name v3param
SI 4093(config)# snmp-server target-parameters 11 name v3param
SI 4093(config)# snmp-server target-parameters 11 user-name v3trap
SI 4093(config)# snmp-server target-parameters 11 level authNoPriv
```

**Note:** IBM Networking OS 7.7 supports only IPv4 addresses for SNMP trap hosts.

---

## SNMP MIBs

The IBM Networking OS SNMP agent supports SNMP version 3. Security is provided through SNMP community strings. The default community strings are “public” for SNMP GET operation and “private” for SNMP SET operation. The community string can be modified only through the Command Line Interface (CLI). Detailed SNMP MIBs and trap definitions of the IBM Networking OS SNMP agent are contained in the following IBM Networking OS enterprise MIB document:

GbFSIM-10G-L2.mib

The IBM Networking OS SNMP agent supports the following standard MIBs:

- dot1x.mib
- ieee8021ab.mib
- ieee8023ad.mib
- lldpxdcbx.mib
- rfc1213.mib
- rfc1215.mib
- rfc1493.mib
- rfc1573.mib
- rfc1643.mib
- rfc1657.mib
- rfc1850.mib
- rfc1907.mib
- rfc2037.mib
- rfc2233.mib
- rfc2465.mib
- rfc2571.mib
- rfc2572.mib
- rfc2573.mib
- rfc2574.mib
- rfc2575.mib
- rfc2576.mib
- rfc3176.mib

The IBM Networking OS SNMP agent supports the following generic traps as defined in RFC 1215:

- ColdStart
- WarmStart
- LinkDown
- LinkUp
- AuthenticationFailure

The following are the enterprise SNMP traps supported in IBM Networking OS:

*Table 18. IBM Networking OS-Supported Enterprise SNMP Traps*

Trap Name	Description
altSwDefGwUp	Signifies that the default gateway is alive.
altSwDefGwDown	Signifies that the default gateway is down.

Table 18. IBM Networking OS-Supported Enterprise SNMP Traps (continued)

Trap Name	Description
altSwDefGwInService	Signifies that the default gateway is up and in service
altSwDefGwNotInService	Signifies that the default gateway is alive but not in service
altSwLoginFailure	Signifies that someone failed to enter a valid username/password combination.
altSwTempExceedThreshold	Signifies that the switch temperature has exceeded maximum safety limits.
altSwTempReturnThreshold	Signifies that the switch temperature has returned below maximum safety limits.
altSwStgNewRoot	Signifies that the bridge has become the new root of the STG.
altSwStgTopologyChanged	Signifies that there was a STG topology change.
altSwStgBlockingState	An altSwStgBlockingState trap is sent when port state is changed in blocking state.
altSwCistNewRoot	Signifies that the bridge has become the new root of the CIST.
altSwCistTopologyChanged	Signifies that there was a CIST topology change.
altSwHotlinksMasterUp	Signifies that the Master interface is active.
altSwHotlinksMasterDn	Signifies that the Master interface is not active.
altSwHotlinksBackupUp	Signifies that the Backup interface is active.
altSwHotlinksBackupDn	Signifies that the Backup interface is not active.
altSwHotlinksNone	Signifies that there are no active interfaces.
altSwValidLogin	Signifies that a user login has occurred.
altSwValidLogout	Signifies that a user logout has occurred.
altVMGroupVMotion	Signifies that a virtual machine has moved from a port to another.
altVMGroupVMOnline	Signifies that a advance provisioned virtual machine has come online.
altVMGroupVMVlanChange	Signifies that a virtual machine has entered into a VLAN, or changed the VLAN.

---

## Switch Images and Configuration Files

This section describes how to use MIB calls to work with switch images and configuration files. You can use a standard SNMP tool to perform the actions, using the MIBs listed in [Table 19](#).

[Table 19](#) lists the MIBs used to perform operations associated with the Switch Image and Configuration files.

*Table 19. MIBs for Switch Image and Configuration Files*

MIB Name	MIB OID
agTransferServer	1.3.6.1.4.1872.2.5.1.1.7.1.0
agTransferImage	1.3.6.1.4.1872.2.5.1.1.7.2.0
agTransferImageFileName	1.3.6.1.4.1872.2.5.1.1.7.3.0
agTransferCfgFileName	1.3.6.1.4.1872.2.5.1.1.7.4.0
agTransferDumpFileName	1.3.6.1.4.1872.2.5.1.1.7.5.0
agTransferAction	1.3.6.1.4.1872.2.5.1.1.7.6.0
agTransferLastActionStatus	1.3.6.1.4.1872.2.5.1.1.7.7.0
agTransferUserName	1.3.6.1.4.1872.2.5.1.1.7.9.0
agTransferPassword	1.3.6.1.4.1.1872.2.5.1.1.7.10.0
agTransferTSDumpFileName	1.3.6.1.4.1.1872.2.5.1.1.7.11.0

The following SNMP actions can be performed using the MIBs listed in [Table 19](#).

- Load a new Switch image (boot or running) from a FTP/TFTP server
- Load a previously saved switch configuration from a FTP/TFTP server
- Save the switch configuration to a FTP/TFTP server
- Save a switch dump to a FTP/TFTP server



## Loading a New Switch Image

To load a new switch image with the name "MyNewImage-1.img" into image2, follow the steps below. This example shows an FTP/TFTP server at IPv4 address 192.168.10.10, though IPv6 is also supported.

1. Set the FTP/TFTP server address where the switch image resides:  
`Set agTransferServer.0 "192.168.10.10"`
2. Set the area where the new image will be loaded:  
`Set agTransferImage.0 "image2"`
3. Set the name of the image:  
`Set agTransferImageFileName.0 "MyNewImage-1.img"`
4. If you are using an FTP server, enter a username:  
`Set agTransferUserName.0 "MyName"`
5. If you are using an FTP server, enter a password:  
`Set agTransferPassword.0 "MyPassword"`
6. Initiate the transfer. To transfer a switch image, enter 2 (gtimg):  
`Set agTransferAction.0 "2"`

## Loading a Saved Switch Configuration

To load a saved switch configuration with the name "MyRunningConfig.cfg" into the switch, follow the steps below. This example shows a TFTP server at IPv4 address 192.168.10.10, though IPv6 is also supported.

1. Set the FTP/TFTP server address where the switch Configuration File resides:  
`Set agTransferServer.0 "192.168.10.10"`
2. Set the name of the configuration file:  
`Set agTransferCfgFileName.0 "MyRunningConfig.cfg"`
3. If you are using an FTP server, enter a username:  
`Set agTransferUserName.0 "MyName"`
4. If you are using an FTP server, enter a password:  
`Set agTransferPassword.0 "MyPassword"`
5. Initiate the transfer. To restore a running configuration, enter 3:  
`Set agTransferAction.0 "3"`

## Saving the Switch Configuration

To save the switch configuration to a FTP/TFTP server follow the steps below. This example shows a FTP/TFTP server at IPv4 address 192.168.10.10, though IPv6 is also supported.

1. Set the FTP/TFTP server address where the configuration file is saved:  
Set agTransferServer.0 "192.168.10.10"
2. Set the name of the configuration file:  
Set agTransferCfgFileName.0 "MyRunningConfig.cfg"
3. If you are using an FTP server, enter a username:  
Set agTransferUserName.0 "MyName"
4. If you are using an FTP server, enter a password:  
Set agTransferPassword.0 "MyPassword"
5. Initiate the transfer. To save a running configuration file, enter 4:  
Set agTransferAction.0 "4"

## Saving a Switch Dump

To save a switch dump to a FTP/TFTP server, follow the steps below. This example shows an FTP/TFTP server at 192.168.10.10, though IPv6 is also supported.

1. Set the FTP/TFTP server address where the configuration will be saved:  
Set agTransferServer.0 "192.168.10.10"
2. Set the name of dump file:  
Set agTransferDumpFileName.0 "MyDumpFile.dmp"
3. If you are using an FTP server, enter a username:  
Set agTransferUserName.0 "MyName"
4. If you are using an FTP server, enter a password:  
Set agTransferPassword.0 "MyPassword"
5. Initiate the transfer. To save a dump file, enter 5:  
Set agTransferAction.0 "5"

---

## Chapter 18. Service Location Protocol

Service Location Protocol (SLP) allows the switch to provide dynamic directory services that helps users find servers by attributes rather than by name or address. SLP eliminates the need for a user to know the name of a network host supporting a service. SLP allows the user to bind a service description to the network address of the service.

Service Location Protocol is described in RFC 2608.

**Note:** SLP is not supported on the internal management port (MGT).

SLP defines specialized components called agents that perform tasks and support services as follows:

- User Agent (UA) supports service query functions. It requests service information for user applications. The User Agent retrieves service information from the Service Agent or Directory Agents. A Host On-Demand client is an example of a User Agent.
- Service Agent (SA) provides service registration and service advertisement.  
**Note:** In this release, SA supports UA/DA on Linux with SLPv2 support.
- Directory Agent (DA) collects service information from Service Agents to provide a repository of service information in order to centralize it for efficient access by User Agents. There can only be one Directory Agent present per given host.

The Directory Agent acts as an intermediate tier in the SLP architecture, placed between the User Agents and the Service Agents, so they communicate only with the Directory Agent instead of with each other. This eliminates a large portion of the multicast request or reply traffic on the network, and it protects the Service Agents from being overwhelmed by too many service requests.

Services are described by the configuration of attributes associated with a type of service. A User Agent can select an appropriate service by specifying the attributes that it needs in a service request message. When service replies are returned, they contain a Uniform Resource Locator (URL) pointing to the service desired, and other information, such as server load, needed by the User Agent.

---

## Active DA Discovery

When a Service Agent or User Agent initializes, it can perform Active Directory Agent Discovery using a multicast service request and specifies the special, reserved service type (`service:directory-agent`). Active DA Discovery is achieved through the same mechanism as any other discovery using SLP.

The Directory Agent replies with unicast service replies, which provides the URLs and attributes of the requested service.

---

## SLP Configuration

Use the following CLI commands to configure SLP for the switch:

*Table 20. SLP Commands*

Command Syntax and Usage
<code>[no] ip slp enable</code> Enables or disables SLP on the switch. <b>Command mode:</b> Global configuration
<code>[no] ip slp active-da-discovery enable</code> Enables or disables Active DA Discovery. <b>Command mode:</b> Global configuration
<code>ip slp active-da-discovery-start-wait-time &lt;1-10&gt;</code> Configures the wait time before starting Active DA Discovery, in seconds. The default value is 3 seconds. <b>Command mode:</b> Global configuration
<code>clear ip slp directory-agents</code> Clears all Directory Agents learned by the switch. <b>Command mode:</b> Global configuration

---

## Chapter 19. Layer 2 Failover

The primary application for Layer 2 Failover is to support Network Adapter Teaming. With Network Adapter Teaming, all the NICs on each server share the same IP address, and are configured into a team. One NIC is the primary link, and the other is a standby link. For more details, refer to the documentation for your Ethernet adapter.

**Note:** Only two links per server blade can be used for Layer 2 Trunk Failover (one primary and one backup). Network Adapter Teaming allows only one backup NIC for each server blade.

---

### Setting the Failover Limit

The failover limit lets you specify the minimum number of operational links required within each trigger before the trigger initiates a failover event. For example, if the limit is two, a failover event occurs when the number of operational links in the trigger is two or fewer. When you set the limit to zero, the switch triggers a failover event only when no links in the trigger are operational.

---

### Manually Monitoring Port Links

The Manual Monitor allows you to configure a set of ports and/or trunks to monitor for link failures (a monitor list), and another set of ports and/or trunks to disable when the trigger limit is reached (a control list). When the switch detects a link failure on the monitor list, it automatically disables the items in control list. When server ports are disabled, the corresponding server's network adapter can detect the disabled link, and trigger a network-adapter failover to another port or trunk on the switch, or another switch in the chassis.

The switch automatically enables the control list items when the monitor list items return to service.

#### Monitor Port State

A monitor port is considered operational as long as the following conditions are true:

- The port must be in the `Link Up` state.
- If the port is part of an LACP trunk, the port must be in the `Aggregated` state.

If any of the above conditions is false, the monitor port is considered to have failed.

## Control Port State

A control port is considered Operational if the monitor trigger is up. As long as the trigger is up, the port is considered operational from a teaming perspective, even if the port itself is actually in the Down state or Not Aggregated state (if part of an LACP trunk).

A control port is considered to have failed only if the monitor trigger is in the Down state.

To view the state of any port, use one of the following commands:

>> # show interface link	<i>(View port link status)</i>
>> # show lacp information	<i>(View port LACP status)</i>

---

## Configuration Guidelines

This section provides important information about configuring Layer 2 Failover.

- A Manual Monitor can monitor only external ports.
- Any specific failover trigger can monitor external ports only, static trunks only, or LACP trunks only. The different types cannot be combined in the same trigger.
- A maximum of two LACP keys can be added per trigger.
- Port membership for different triggers should not overlap. Any specific port should be a member of only one trigger.

---

## Configuring Layer 2 Failover

### Manual Monitor Example

Use the following procedure to configure a Layer 2 Failover Manual Monitor.

1. Specify the links to monitor.

```
>> # failover trigger 1 mmon monitor member ext1-ext5
```

2. Specify the links to disable when the failover limit is reached.

```
>> # failover trigger 1 mmon control member inta1-inta14
```

3. Configure general Failover parameters.

```
>> # failover enable  
>> # failover trigger 1 enable  
>> # failover trigger 1 limit 2
```

---

## Appendix A. Getting help and technical assistance

If you need help, service, or technical assistance or just want more information about IBM products, you will find a wide variety of sources available from IBM to assist you. This section contains information about where to go for additional information about IBM and IBM products, what to do if you experience a problem with your system, and whom to call for service, if it is necessary.

---

### Before you call

Before you call, make sure that you have taken these steps to try to solve the problem yourself:

- Check all cables to make sure that they are connected.
- Check the power switches to make sure that the system and any optional devices are turned on.
- Use the troubleshooting information in your system documentation, and use the diagnostic tools that come with your system. Information about diagnostic tools is in the *Problem Determination and Service Guide* on the IBM *Documentation CD* that comes with your system.
- Go to the IBM support website at <http://www.ibm.com/systems/support/> to check for technical information, hints, tips, and new device drivers or to submit a request for information.

You can solve many problems without outside assistance by following the troubleshooting procedures that IBM provides in the online help or in the documentation that is provided with your IBM product. The documentation that comes with IBM systems also describes the diagnostic tests that you can perform. Most systems, operating systems, and programs come with documentation that contains troubleshooting procedures and explanations of error messages and error codes. If you suspect a software problem, see the documentation for the operating system or program.

---

### Using the documentation

Information about your IBM system and pre-installed software, if any, or optional device is available in the documentation that comes with the product. That documentation can include printed documents, online documents, ReadMe files, and Help files. See the troubleshooting information in your system documentation for instructions for using the diagnostic programs. The troubleshooting information or the diagnostic programs might tell you that you need additional or updated device drivers or other software. IBM maintains pages on the World Wide Web where you can get the latest technical information and download device drivers and updates. To access these pages, go to <http://www.ibm.com/systems/support/> and follow the instructions. Also, some documents are available through the IBM Publications Center at <http://www.ibm.com/shop/publications/order/>.

---

## Getting help and information on the World Wide Web

On the World Wide Web, the IBM website has up-to-date information about IBM systems, optional devices, services, and support. The address for IBM System x<sup>®</sup> and xSeries<sup>®</sup> information is <http://www.ibm.com/systems/x/>. The address for IBM Flex System information is <http://www.ibm.com/systems/bladecenter/>. The address for IBM IntelliStation<sup>®</sup> information is <http://www.ibm.com/intellistation/>.

You can find service information for IBM systems and optional devices at <http://www.ibm.com/systems/support/>.

---

## Software service and support

Through IBM Support Line, you can get telephone assistance, for a fee, with usage, configuration, and software problems with System x and x Series servers, Flex System products, IntelliStation workstations, and appliances. For information about which products are supported by Support Line in your country or region, see <http://www.ibm.com/services/sl/products/>.

For more information about Support Line and other IBM services, see <http://www.ibm.com/services/>, or see <http://www.ibm.com/planetwide/> for support telephone numbers. In the U.S. and Canada, call 1-800-IBM-SERV (1-800-426-7378).

---

## Hardware service and support

You can receive hardware service through your IBM reseller or IBM Services. To locate a reseller authorized by IBM to provide warranty service, go to <http://www.ibm.com/partnerworld/> and click **Find Business Partners** on the right side of the page. For IBM support telephone numbers, see <http://www.ibm.com/planetwide/>. In the U.S. and Canada, call 1-800-IBM-SERV (1-800-426-7378).

In the U.S. and Canada, hardware service and support is available 24 hours a day, 7 days a week. In the U.K., these services are available Monday through Friday, from 9 a.m. to 6 p.m.



---

## IBM Taiwan product service

台灣 IBM 產品服務聯絡方式：  
台灣國際商業機器股份有限公司  
台北市松仁路7號3樓  
電話：0800-016-888

IBM Taiwan product service contact information:

IBM Taiwan Corporation  
3F, No 7, Song Ren Rd.  
Taipei, Taiwan  
Telephone: 0800-016-888



---

## Appendix B. Notices

This information was developed for products and services offered in the U.S.A.

IBM may not offer the products, services, or features discussed in this document in other countries. Consult your local IBM representative for information on the products and services currently available in your area. Any reference to an IBM product, program, or service is not intended to state or imply that only that IBM product, program, or service may be used. Any functionally equivalent product, program, or service that does not infringe any IBM intellectual property right may be used instead. However, it is the user's responsibility to evaluate and verify the operation of any non-IBM product, program, or service.

IBM may have patents or pending patent applications covering subject matter described in this document. The furnishing of this document does not give you any license to these patents. You can send license inquiries, in writing, to:

*IBM Director of Licensing  
IBM Corporation  
North Castle Drive  
Armonk, NY 10504-1785  
U.S.A.*

INTERNATIONAL BUSINESS MACHINES CORPORATION PROVIDES THIS PUBLICATION "AS IS" WITHOUT WARRANTY OF ANY KIND, EITHER EXPRESS OR IMPLIED, INCLUDING, BUT NOT LIMITED TO, THE IMPLIED WARRANTIES OF NON-INFRINGEMENT, MERCHANTABILITY OR FITNESS FOR A PARTICULAR PURPOSE. Some states do not allow disclaimer of express or implied warranties in certain transactions, therefore, this statement may not apply to you.

This information could include technical inaccuracies or typographical errors. Changes are periodically made to the information herein; these changes will be incorporated in new editions of the publication. IBM may make improvements and/or changes in the product(s) and/or the program(s) described in this publication at any time without notice.

Any references in this information to non-IBM websites are provided for convenience only and do not in any manner serve as an endorsement of those websites. The materials at those websites are not part of the materials for this IBM product, and use of those websites is at your own risk.

IBM may use or distribute any of the information you supply in any way it believes appropriate without incurring any obligation to you.

---

## Trademarks

IBM, the IBM logo, and [ibm.com](http://www.ibm.com) are trademarks or registered trademarks of International Business Machines Corporation in the United States, other countries, or both. If these and other IBM trademarked terms are marked on their first occurrence in this information with a trademark symbol (® or ™), these symbols indicate U.S. registered or common law trademarks owned by IBM at the time this information was published. Such trademarks may also be registered or common law trademarks in other countries. A current list of IBM trademarks is available on the web at "Copyright and trademark information" at <http://www.ibm.com/legal/copytrade.shtml>.

Adobe and PostScript are either registered trademarks or trademarks of Adobe Systems Incorporated in the United States and/or other countries.

Cell Broadband Engine is a trademark of Sony Computer Entertainment, Inc., in the United States, other countries, or both and is used under license therefrom.

Intel, Intel Xeon, Itanium, and Pentium are trademarks or registered trademarks of Intel Corporation or its subsidiaries in the United States and other countries.

Java and all Java-based trademarks are trademarks of Sun Microsystems, Inc., in the United States, other countries, or both.

Linux is a registered trademark of Linus Torvalds in the United States, other countries, or both.

Microsoft, Windows, and Windows NT are trademarks of Microsoft Corporation in the United States, other countries, or both.

UNIX is a registered trademark of The Open Group in the United States and other countries.

Other company, product, or service names may be trademarks or service marks of others.

---

## Important Notes

Processor speed indicates the internal clock speed of the microprocessor; other factors also affect application performance.

CD or DVD drive speed is the variable read rate. Actual speeds vary and are often less than the possible maximum.

When referring to processor storage, real and virtual storage, or channel volume, KB stands for 1024 bytes, MB stands for 1 048 576 bytes, and GB stands for 1 073 741 824 bytes.

When referring to hard disk drive capacity or communications volume, MB stands for 1 000 000 bytes, and GB stands for 1 000 000 000 bytes. Total user-accessible capacity can vary depending on operating environments.

Maximum internal hard disk drive capacities assume the replacement of any standard hard disk drives and population of all hard disk drive bays with the largest currently supported drives that are available from IBM.

Maximum memory might require replacement of the standard memory with an optional memory module.

IBM makes no representation or warranties regarding non-IBM products and services that are ServerProven, including but not limited to the implied warranties of merchantability and fitness for a particular purpose. These products are offered and warranted solely by third parties.

IBM makes no representations or warranties with respect to non-IBM products. Support (if any) for the non-IBM products is provided by the third party, not IBM.

Some software might differ from its retail version (if available) and might not include user manuals or all program functionality.

## Particulate contamination

**Attention:** Airborne particulates (including metal flakes or particles) and reactive gases acting alone or in combination with other environmental factors such as humidity or temperature might pose a risk to the device that is described in this document. Risks that are posed by the presence of excessive particulate levels or concentrations of harmful gases include damage that might cause the device to malfunction or cease functioning altogether. This specification sets forth limits for particulates and gases that are intended to avoid such damage. The limits must not be viewed or used as definitive limits, because numerous other factors, such as temperature or moisture content of the air, can influence the impact of particulates or environmental corrosives and gaseous contaminant transfer. In the absence of specific limits that are set forth in this document, you must implement practices that maintain particulate and gas levels that are consistent with the protection of human health and safety. If IBM determines that the levels of particulates or gases in your environment have caused damage to the device, IBM may condition provision of repair or replacement of devices or parts on implementation of appropriate remedial measures to mitigate such environmental contamination. Implementation of such remedial measures is a customer responsibility.

Contaminant	Limits
Particulate	<ul style="list-style-type: none"> <li>The room air must be continuously filtered with 40% atmospheric dust spot efficiency (MERV 9) according to ASHRAE Standard 52.2<sup>1</sup>.</li> <li>Air that enters a data center must be filtered to 99.97% efficiency or greater, using high-efficiency particulate air (HEPA) filters that meet MIL-STD-282.</li> <li>The deliquescent relative humidity of the particulate contamination must be more than 60%<sup>2</sup>.</li> <li>The room must be free of conductive contamination such as zinc whiskers.</li> </ul>
Gaseous	<ul style="list-style-type: none"> <li>Copper: Class G1 as per ANSI/ISA 71.04-1985<sup>3</sup></li> <li>Silver: Corrosion rate of less than 300 Å in 30 days</li> </ul>

<sup>1</sup> ASHRAE 52.2-2008 - *Method of Testing General Ventilation Air-Cleaning Devices for Removal Efficiency by Particle Size*. Atlanta: American Society of Heating, Refrigerating and Air-Conditioning Engineers, Inc.

<sup>2</sup> The deliquescent relative humidity of particulate contamination is the relative humidity at which the dust absorbs enough water to become wet and promote ionic conduction.

<sup>3</sup> ANSI/ISA-71.04-1985. *Environmental conditions for process measurement and control systems: Airborne contaminants*. Instrument Society of America, Research Triangle Park, North Carolina, U.S.A.

---

## Documentation format

The publications for this product are in Adobe Portable Document Format (PDF) and should be compliant with accessibility standards. If you experience difficulties when you use the PDF files and want to request a web-based format or accessible PDF document for a publication, direct your mail to the following address:

Information Development  
IBM Corporation  
205/A0153039 E. Cornwallis Road  
P.O. Box 12195  
Research Triangle Park, North Carolina 27709-2195  
U.S.A.

In the request, be sure to include the publication part number and title.

When you send information to IBM, you grant IBM a non-exclusive right to use or distribute the information in any way it believes appropriate without incurring any obligation to you.

---

## Electronic emission notices

### Federal Communications Commission (FCC) statement

**Note:** This equipment has been tested and found to comply with the limits for a Class A digital device, pursuant to Part 15 of the FCC Rules. These limits are designed to provide reasonable protection against harmful interference when the equipment is operated in a commercial environment. This equipment generates, uses, and can radiate radio frequency energy and, if not installed and used in accordance with the instruction manual, may cause harmful interference to radio communications. Operation of this equipment in a residential area is likely to cause harmful interference, in which case the user will be required to correct the interference at his own expense.

Properly shielded and grounded cables and connectors must be used in order to meet FCC emission limits. IBM is not responsible for any radio or television interference caused by using other than recommended cables and connectors or by unauthorized changes or modifications to this equipment. Unauthorized changes or modifications could void the user's authority to operate the equipment.

This device complies with Part 15 of the FCC Rules. Operation is subject to the following two conditions: (1) this device may not cause harmful interference, and (2) this device must accept any interference received, including interference that may cause undesired operation.

### Industry Canada Class A emission compliance statement

This Class A digital apparatus complies with Canadian ICES-003.

### Avis de conformité à la réglementation d'Industrie Canada

Cet appareil numérique de la classe A est conforme à la norme NMB-003 du Canada.

### Australia and New Zealand Class A statement

**Attention:** This is a Class A product. In a domestic environment this product may cause radio interference in which case the user may be required to take adequate measures.

### European Union EMC Directive conformance statement

This product is in conformity with the protection requirements of EU Council Directive 2004/108/EC on the approximation of the laws of the Member States relating to electromagnetic compatibility. IBM cannot accept responsibility for any failure to satisfy the protection requirements resulting from a nonrecommended modification of the product, including the fitting of non-IBM option cards.

**Attention:** This is an EN 55022 Class A product. In a domestic environment this product may cause radio interference in which case the user may be required to take adequate measures.



Responsible manufacturer:

International Business Machines Corp.  
New Orchard Road  
Armonk, New York 10504  
914-499-1900

European Community contact:

IBM Technical Regulations, Department M456  
IBM-Allee 1, 71137 Ehningen, Germany  
Telephone: +49 7032 15-2937  
E-mail: tjahn@de.ibm.com

## Germany Class A statement

### Deutschsprachiger EU Hinweis:

#### Hinweis für Geräte der Klasse A EU-Richtlinie zur Elektromagnetischen Verträglichkeit

Dieses Produkt entspricht den Schutzanforderungen der EU-Richtlinie 2004/108/EG zur Angleichung der Rechtsvorschriften über die elektromagnetische Verträglichkeit in den EU-Mitgliedsstaaten und hält die Grenzwerte der EN 55022 Klasse A ein.

Um dieses sicherzustellen, sind die Geräte wie in den Handbüchern beschrieben zu installieren und zu betreiben. Des Weiteren dürfen auch nur von der IBM empfohlene Kabel angeschlossen werden. IBM übernimmt keine Verantwortung für die Einhaltung der Schutzanforderungen, wenn das Produkt ohne Zustimmung der IBM verändert bzw. wenn Erweiterungskomponenten von Fremdherstellern ohne Empfehlung der IBM gesteckt/eingebaut werden.

EN 55022 Klasse A Geräte müssen mit folgendem Warnhinweis versehen werden: "Warnung: Dieses ist eine Einrichtung der Klasse A. Diese Einrichtung kann im Wohnbereich Funk-Störungen verursachen; in diesem Fall kann vom Betreiber verlangt werden, angemessene Maßnahmen zu ergreifen und dafür aufzukommen."

#### Deutschland: Einhaltung des Gesetzes über die elektromagnetische Verträglichkeit von Geräten

Dieses Produkt entspricht dem "Gesetz über die elektromagnetische Verträglichkeit von Geräten (EMVG)". Dies ist die Umsetzung der EU-Richtlinie 2004/108/EG in der Bundesrepublik Deutschland.

#### Zulassungsbescheinigung laut dem Deutschen Gesetz über die elektromagnetische Verträglichkeit von Geräten (EMVG) (bzw. der EMC EG Richtlinie 2004/108/EG) für Geräte der Klasse A

Dieses Gerät ist berechtigt, in Übereinstimmung mit dem Deutschen EMVG das EG-Konformitätszeichen - CE - zu führen.

Verantwortlich für die Einhaltung der EMV Vorschriften ist der Hersteller:

International Business Machines Corp.  
New Orchard Road  
Armonk, New York 10504  
914-499-1900

Der verantwortliche Ansprechpartner des Herstellers in der EU ist:

IBM Deutschland  
Technical Regulations, Department M456  
IBM-Allee 1, 71137 Ehningen, Germany  
Telephone: +49 7032 15-2937  
E-mail: tjahn@de.ibm.com

**Generelle Informationen:**

**Das Gerät erfüllt die Schutzanforderungen nach EN 55024 und EN 55022 Klasse A.**

## Japan VCCI Class A statement

この装置は、クラス A 情報技術装置です。この装置を家庭環境で使用する  
と電波妨害を引き起こすことがあります。この場合には使用者が適切な対策  
を講ずるよう要求されることがあります。 VCCI-A

This is a Class A product based on the standard of the Voluntary Control Council for Interference (VCCI). If this equipment is used in a domestic environment, radio interference may occur, in which case the user may be required to take corrective actions.

## Korea Communications Commission (KCC) statement

이 기기는 업무용으로 전자파 적합등록을 받은 기기  
이오니, 판매자 또는 사용자는 이점을 주의하시기  
바라며, 만약 잘못 구입하셨을 때에는 구입한 곳에  
서 비업무용으로 교환하시기 바랍니다.

Please note that this equipment has obtained EMC registration for commercial use. In the event that it has been mistakenly sold or purchased, please exchange it for equipment certified for home use.

## Russia Electromagnetic Interference (EMI) Class A statement

ВНИМАНИЕ! Настоящее изделие относится к классу А.  
В жилых помещениях оно может создавать радиопомехи, для  
снижения которых необходимы дополнительные меры

## People's Republic of China Class A electronic emission statement

中华人民共和国“A类”警告声明

声明  
此为A级产品，在生活环境中，该产品可能会造成无线电干扰。在这种情况下，  
可能需要用户对其干扰采取切实可行的措施。

## Taiwan Class A compliance statement

警告使用者：  
這是甲類的資訊產品，在居住的環境中使用時，可能會造成射頻干擾，在這種情況下，使用者會被要求採取某些適當的對策。



---

# Index

## Symbols

[ ] 11

## Numerics

40GbE ports 85  
802.1p QoS 119  
802.1Q VLAN tagging 130  
802.1Qaz ETS 130  
802.1Qbb PFC 126  
802.3x flow control 120, 126

## A

Access Control Lists. *See* ACLs.  
accessible documentation 175  
accessing the switch  
    LDAP 53  
    RADIUS authentication 45  
    security 45  
ACLs 55, 99  
    FCoE 123  
    FIP snooping 116, 121  
administrator account 25, 47  
advertise flag (DCBX) 137  
anycast address, IPv6 107  
application ports 57  
assistance, getting 167  
autoconfiguration  
    link 30  
autoconfiguration, IPv6 108  
auto-negotiation  
    setup 30

## B

bandwidth allocation 119, 133  
bridge module 115, 140

## C

CEE 118  
    802.1p QoS 119  
    bandwidth allocation 119  
    DCBX 118, 136  
    ETS 119, 130  
    FCoE 117, 118  
    LLDP 118  
    on/off 118  
    PFC 120, 126  
    priority groups 131  
Cisco EtherChannel 89  
Class A electronic emission notice 176  
Class of Service queue 102  
CNA 116, 117

command conventions 11  
configuration rules  
    CEE 118  
    FCoE 117  
    port mirroring 89  
    spanning tree 89  
    Trunking 89  
    VLANs 89  
configuring  
    DCBX 138  
    ETS 134  
    FIP snooping 125  
    PFC 128  
    port trunking 90  
contamination, particulate and gaseous 174  
Converged Network Adapter. *See* CNA.

## D

date  
    setup 28  
DCBX 118, 136  
default password 25, 47  
documentation format 175  
downloading software 64

## E

electronic emission Class A notice 176  
End user access control, configuring 41  
ENodes 116, 121  
EtherChannel 87  
    as used with port trunking 89  
Ethernet Nodes (FCoE). *See* ENodes.  
ETS 119, 130  
    bandwidth allocation 119, 133  
    configuring 134  
    DCBX 138  
    PGID 119, 131  
    priority groups 131  
    priority values 132

## F

factory default configuration 27  
failover 165  
FC-BB-5 115  
FCC Class A notice 176  
FCF 115, 117, 121  
    detection mode 122

- FCoE 115
  - bridge module 115, 140
  - CEE 117, 118
  - CNA 116, 117
  - ENodes 116
  - FCF 115, 117
  - FIP snooping 116, 121
  - FLOGI 123
  - point-to-point links 115
  - requirements 117
  - SAN 115, 118
  - topology 115
  - VLANs 123
- FCoE Forwarder. *See* FCF.
- Fibre Channel over Ethernet. *See* FCoE.
- Final Steps 33
- FIP snooping 116, 121
  - ACL rules 123
  - ENode mode 122
  - FCF mode 122
  - timeout 122
- first-time configuration 27 to ??
- FLOGI 123
- flow control 120, 126
  - setup 30

## G

- gaseous contamination 174
- getting help 167

## H

- hardware service and support 168
- help, getting 167
- http
  - //www.ibm.com/systems/support 63

## I

- IBM Director 153
- IBM DirectorSNMP
  - IBM Director 22
- IBM support line 168
- ICMP 56
- IEEE standards
  - 802.1Qaz 130
  - 802.1Qbb 126
  - 802.3x 126
- IGMP 56
- image
  - downloading 64
- INCITS T11.3 115
- IP address 30, 31, 32
  - IP interface 30, 31, 32
- IP configuration via setup 30
- IP interfaces 30, 31, 32
- IP subnet mask 31, 32

- IPv6 addressing 105, 106
- ISL Trunking 87

## L

- LACP 93
- Layer 2 Failover 165
- LDAP authentication 53
- Link Aggregation Control Protocol 93
- LLDP 118, 137
- lossless Ethernet 115, 118

## M

- management module 20
- manual style conventions 11
- meter 60, 100
- multi-links between switches using port trunking 87

## N

- Neighbor Discovery, IPv6 109
- network management 19, 22, 153
- notes, important 173
- notices 171
- notices, electronic emission 176
- notices, FCC Class A 176

## O

- OSPF
  - filtering criteria 56

## P

- particulate contamination 174
- password
  - administrator account 25, 47
  - default 25, 47
  - user account 25, 47
- passwords 24
- PFC 120, 126
  - DCBX 138
- PGID 119, 131
- port flow control. *See* flow control.
- port mirroring
  - configuration rules 89
- port modes 85
- port trunking
  - configuration example 90
  - EtherChannel 87
- ports
  - configuration 29
  - for services 57
- priority groups 131
- priority value (802.1p) 101, 120, 130
- protocol types 56

## Q

QSFP+ 85

## R

RADIUS

- authentication 45
  - port 1812 and 1645 57
  - port 1813 57
- SSH/SCP 40

re-mark 60, 100

restarting switch setup 28

routers

- port trunking 87

RSA keys 40

## S

SAN 115, 118

security

- LDAP authentication 53
- RADIUS authentication 45

service and support 168

service ports 57

setup facility 27

- IP configuration 30
- IP subnet mask 31, 32
- port auto-negotiation mode 30
- port configuration 29
- port flow control 30
- restarting 28
- starting 27
- stopping 28
- system date 28
- system time 29

SNMP 19, 22, 153

SNMP Agent 153

software

- image 63

software service and support 168

Spanning Tree Protocol

- configuration rules 89

SSH/SCP

- configuring 37

- RSA host and server keys 40

starting switch setup 27

stopping switch setup 28

Storage Area Network. *See* SAN.

subnet mask 31, 32

support line 168

support web site 168

## T

TACACS+ 49

TCP 56

technical assistance 167

telephone assistance 168

telephone numbers 169

Telnet support

- optional setup for Telnet support 34

text conventions 11

time

- setup 29

trademarks 172

Trunking configuration rules 89

typographic conventions 11

## U

UDP 56

upgrade, switch software 63

user account 25, 47

## V

VLANs

- configuration rules 89

- FCoE 123

## W

website, publication ordering 167

website, support 168

website, telephone support numbers 168

willing flag (DCBX) 137









Part Number: 00CG189

Printed in USA

(IP) P/N: 00CG189